

JRG

Montageanleitung / Instructions de montage
Istruzioni per il montaggio / Installation instructions

Verlängerungs-Set zu Gartenventil antifrost Set de prolongation pour robinet de jardin antigel Set di allungamento per rubinetto da giardino, antigelo Extension set for garden valve antifrost

7045.001

Georg Fischer JRG AG

Hauptstrasse 130, CH-4450 Sissach
Phone +41 (0)61 975 22 22, Fax +41 (0)61 975 22 00
info.jrg.ps@georgfischer.com

www.gfps.com

Ident. Nr. 35 56 400 26 / 0.2 / DH / 5.15 / ©Georg Fischer JRG AG

Verpackungsinhalt / Contenu de l'emballage
Contenuto della confezione / Package contents

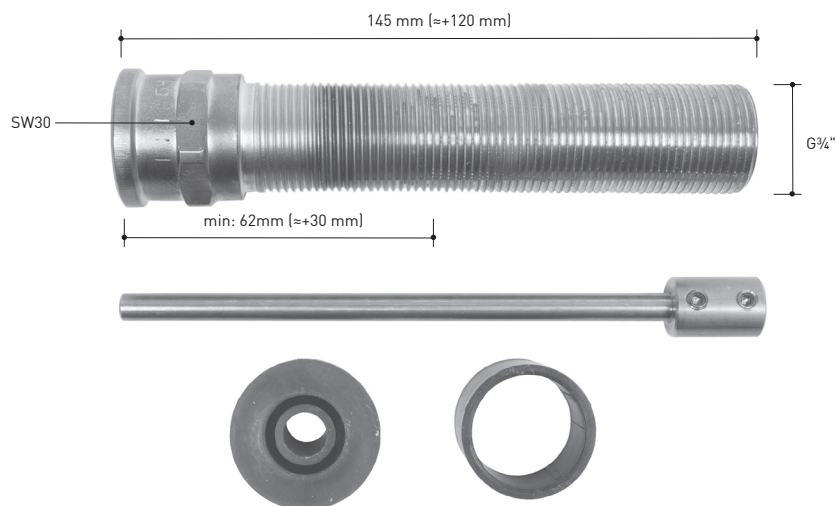

Vor dem Einbau sind die lokal geltenden Normen und Vorschriften zu beachten!
Avant le montage, il convient de respecter les normes et prescriptions localement en vigueur!
Prima dell'installazione, osservare le norme e disposizioni locali vigenti!
Make sure to observe local guidelines and regulations when installing the extension.

+GF+

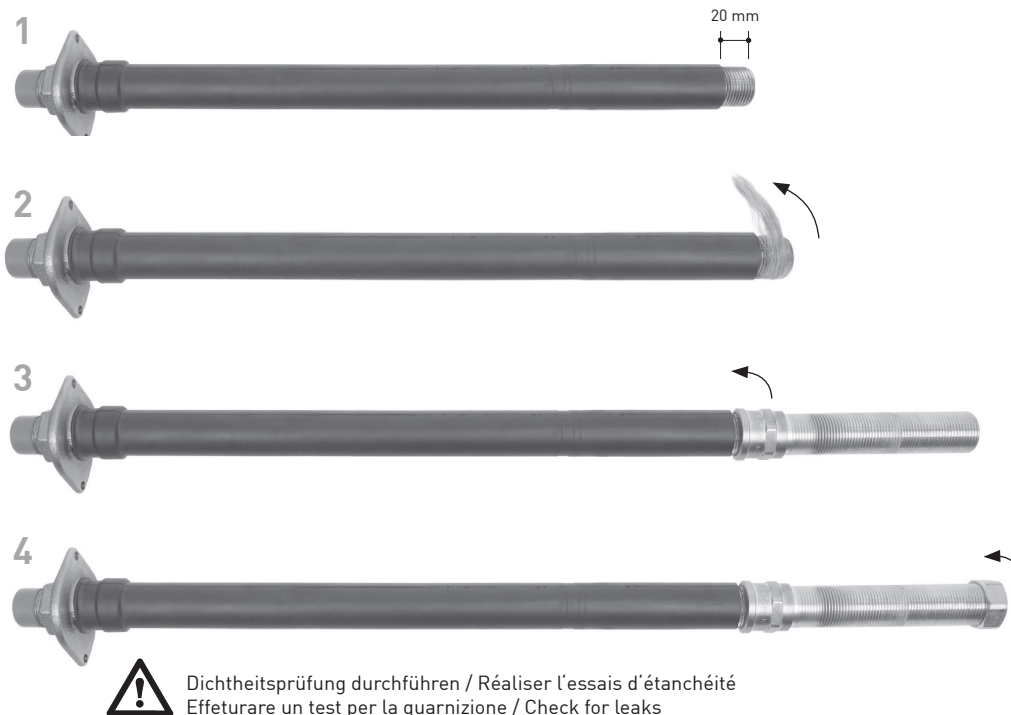

☞ Für den Einbau des Anschlussgehäuses und die Fertigmontage ist die Montage- und Bedienungsanleitung zum Gartenventil antifrost 7040/7045 zu berücksichtigen.
En ce qui concerne le montage final du boîtier de raccordement, veuillez vous référer à l'instruction de montage et d'utilisation du robinet de jardin antigel 7040/7045.
Per il montaggio finale della scatola di raccordo è necessario tenere in considerazione il manuale di montaggio e istruzioni per il rubinetto da giardino antigelo 7040/7045.
For the final assembly of the connection housing we would ask you to refer to the installation and operation manual that comes with your antifrost 7040/7045 garden valve.