

JRG

+GF+

Montageanleitung
Installation instructions
Istruzioni per l'installazione

JRG Sanipex MT

Cembre Akku-Hydraulikeinheit Cembre Battery hydraulic unit Gruppo idraulico a batteria Cembre

CH + EU 4812.000 / 351 600 912

USA + CAN 4812.050 / 351 600 914

DE 2 - 11
EN 12 - 21
IT 22 - 31



CE

1.1 Akku-Aufweitwerkzeug

☑ Bedienungsanleitung zum Werkzeug beachten.

Das Akku-Aufweitwerkzeug ist zusammen mit weiteren Werkzeugen in einem Werkzeugkoffer erhältlich.

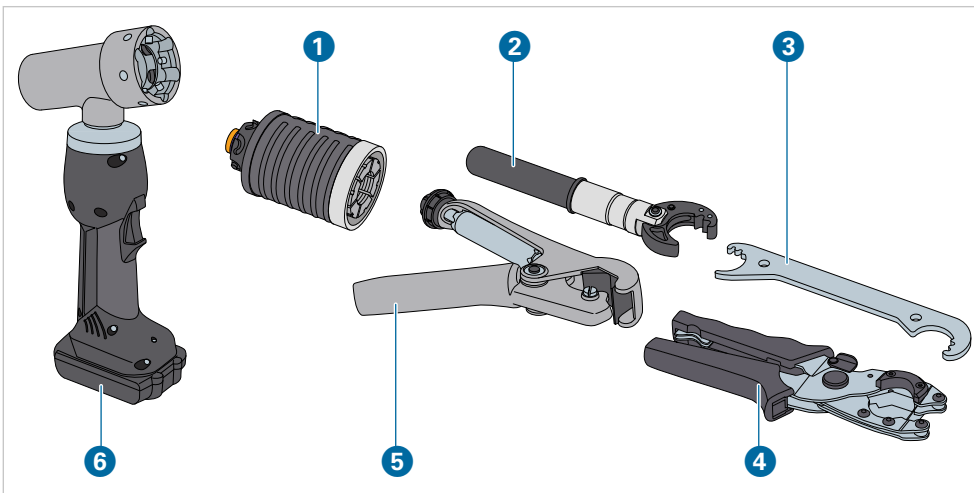

GV.23

Akku-Aufweitwerkzeug

- 1 Aufweitkopf
- 2 Ratschen-drehmomentschlüssel
- 3 Konterschlüssel
- 4 Kombischere
- 5 Rohrabschneider
- 6 Akku-Aufweitwerkzeug

1.2 Hydraulisches Aufweitwerkzeug

☑ Bedienungsanleitung zum Werkzeug beachten.

Das Hydraulische Aufweitwerkzeug ist zusammen mit weiteren Werkzeugen in einem Werkzeugkoffer erhältlich.

Aufweitwerkzeug (d26 ... d40)

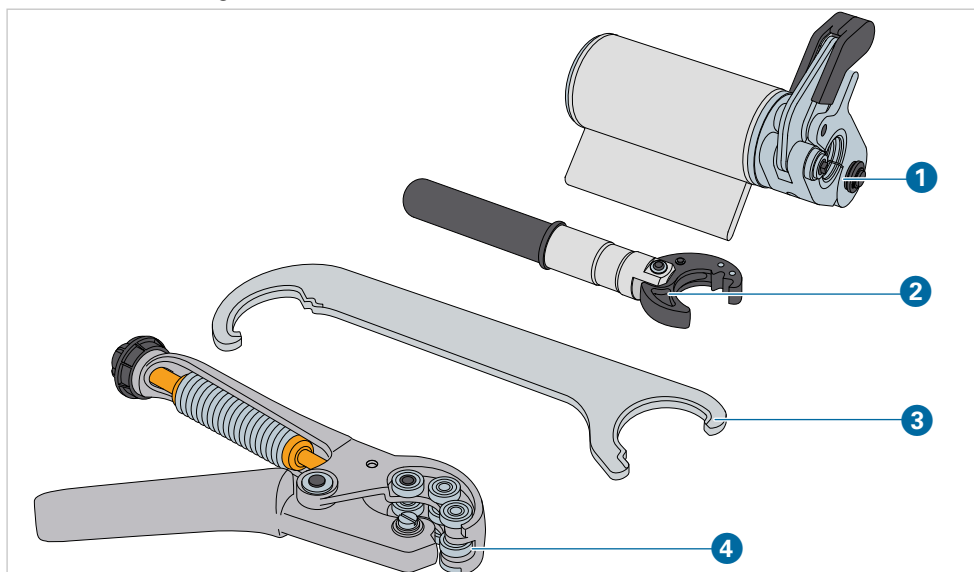

GV.24

Aufweitwerkzeug d26 ... d40

- 1 Aufweitwerkzeug
- 2 Ratschendrehmoment-schlüssel
- 3 Konterschlüssel
- 4 Rohrabschneider

Aufweitwerkzeug (d50 ... d63)

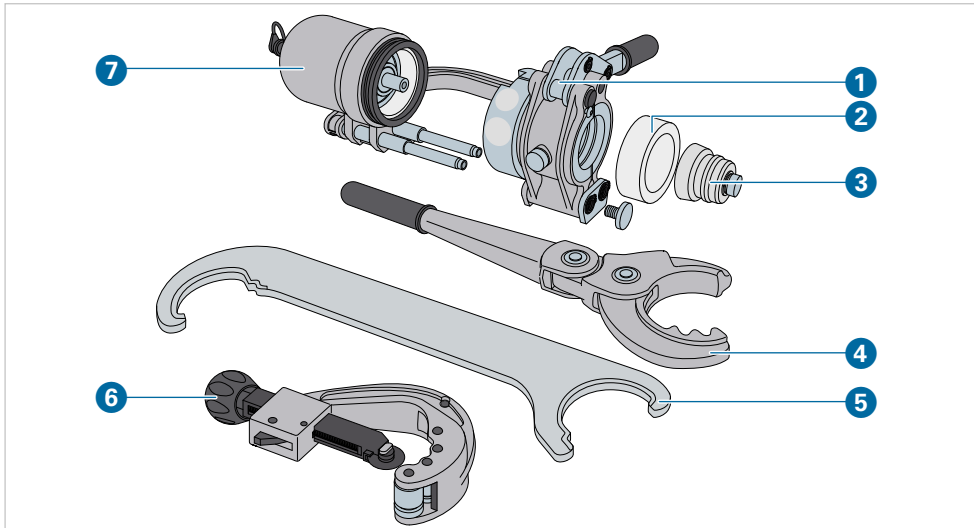

GV.25

Aufweitwerkzeug d50 ... d63

- 1 Bohrspanneinheit
- 2 Rohrabstreifer
- 3 Aufweitdorn
- 4 Ratschendreihmoment-schlüssel
- 5 Konterschlüssel
- 6 Rohrabschneider
- 7 Aufweitwerkzeug

Akkuhydraulische Pumpe

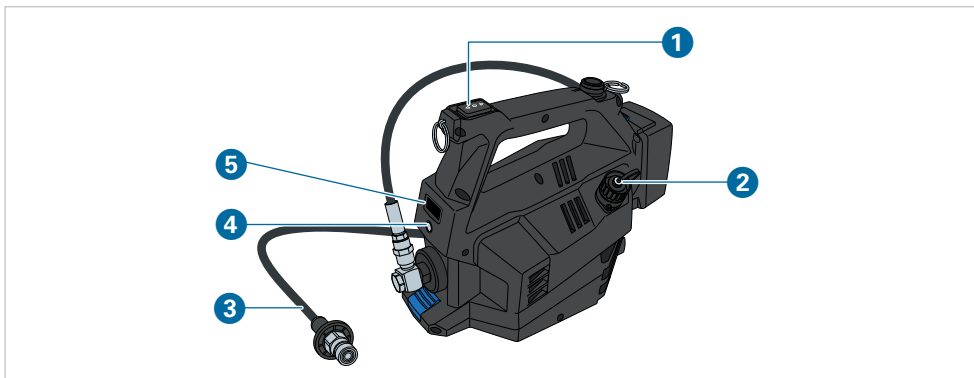

GV.26

Akkuhydraulische Pumpe

- 1 Bedienknopf Aufweiten
- 2 Anschluss Biegewerkzeug
- 3 Hydraulikschlauch
- 4 Wählknopf Menu
- 5 Display

1.3 Biegewerkzeuge

Bedienungsanleitung zum Werkzeug beachten.

Das Biegewerkzeug ist zusammen mit weiteren Werkzeugen in einem Werkzeugkoffer erhältlich.

Biegewerkzeug (d16 ... d63)

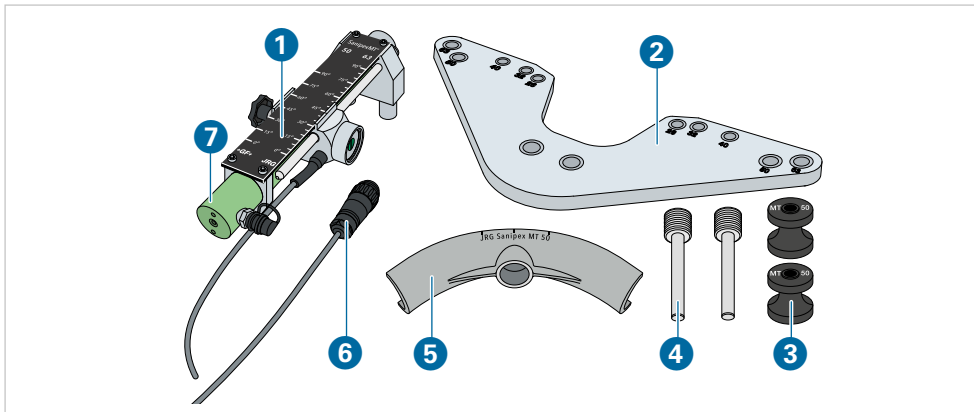

GV.27

Komponenten

- 1 Skala
- 2 Grundplatte
- 3 Biegerollen
- 4 Befestigungsbolzen
- 5 Biegeschablone
- 6 Steuerkabel
- 7 Zylinder

1.4 Pflege, Prüfung und Wartung von Werkzeugen

Ein einwandfrei funktionierendes Werkzeug ist eine Grundvoraussetzung für eine dauerhaft dichte Verbindung.

Verletzungsgefahr und Sachschaden bei falscher Pflege, Prüfung und Wartung.

- Werkzeuge gemäss Angaben in der Bedienungsanleitung pflegen und regelmässig, mindestens einmal jährlich auf Funktion prüfen.

1.5 Aufweiten mit hydraulischem Aufweitwerkzeug

- Bedienungsanleitung zum Werkzeug beachten.
- Sicherstellen, dass das hydraulische Aufweitwerkzeug korrekt funktioniert.

1.5.1 Aufweiten – d26 ... d40

GEFÄHR! Verletzungsgefahr bei Fehlbedienung.

Im Bereich der Anschläge des Spannhebels besteht bei unsachgemässer Bedienung Verletzungsgefahr.

- Bei Handhabung des Spannhebels auf sichere Position der Finger achten.

Montage – Rohr mit hydraulischem Aufweitwerkzeug aufweiten (d26 ... d40)

-  → Hydraulikschlauch an Hydraulikaggregat anschliessen.

Aufweiten durchführen

- ① → Rohrende bis zum Anschlag in das Aufweitwerkzeug einführen.
→ Sicherstellen, dass der Aufweitdorn die gleiche Dimension wie die Spannbacken aufweist. Farbkennzeichnung beachten.
- ② → Rohr gegen den Anschlag des Aufweitdorns drücken und Spanneinheit schliessen.
- ③ → Aufweitvorgang durch Drücken der Starttaste am Hydraulikaggregat auslösen.
→ Starttaste gedrückt halten, bis 130 bar erreicht sind und der Aufweitvorgang mit einem hörbaren „Klack!“ abgeschlossen ist.
↳ Der Aufweitvorgang ist abgeschlossen, wenn der Aufweitdorn vollständig zurückgefahren ist.
- ④ → Spannhebel öffnen.
- ⑤ → Aufgebördeltes Rohr aus dem Aufweitwerkzeug entnehmen.



Montage – Rohr mit hydraulischem Aufweitwerkzeug aufweiten (d26 ... d40)

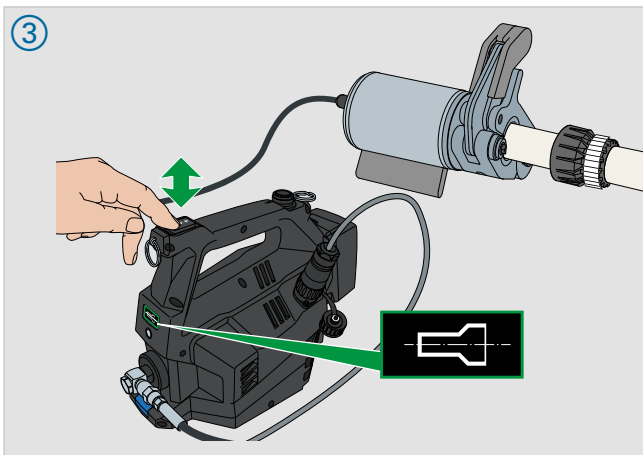
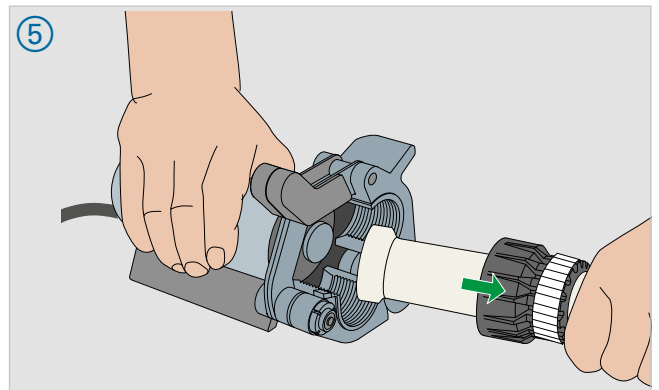
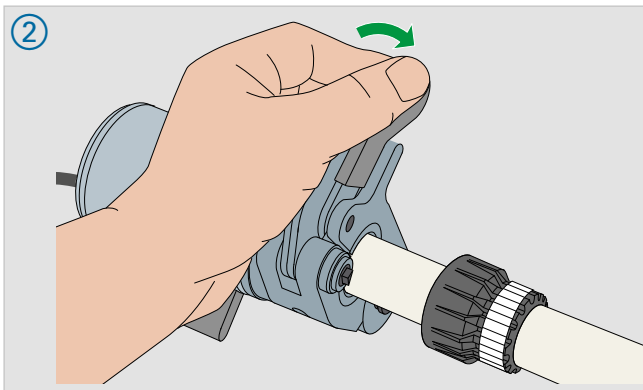
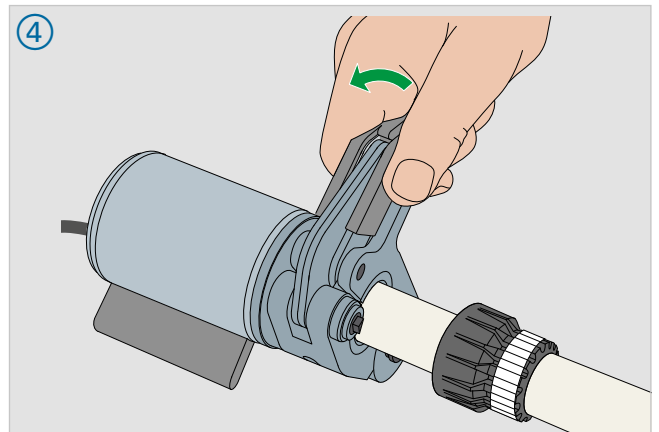
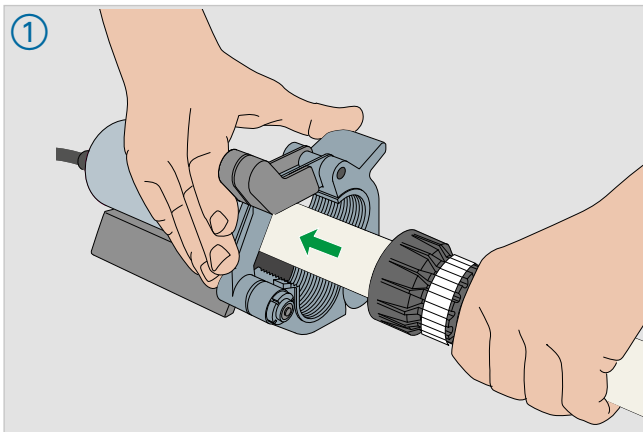

1.5.2 Aufweiten – d50 ... d63

- !** HINWEIS! Falsche Bördellänge durch Anfasen oder Entgraten des Rohrs.
→ Rohr beim Ablängen nicht anfasen oder entgraten.

Das Aufweitwerkzeug kann zur Arbeitserleichterung auch in einen Schraubstock eingespannt werden.

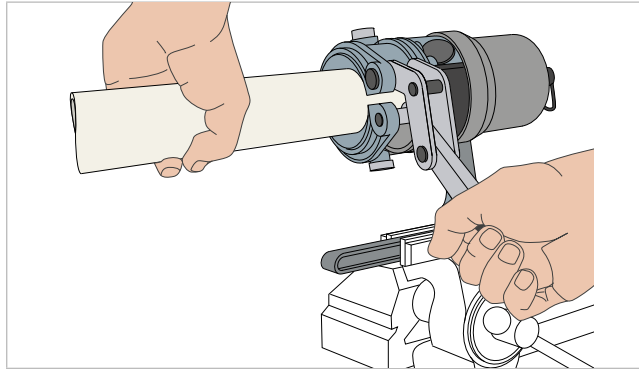

i Die einzelnen Schritte sind auf der nächsten Seite dargestellt.

✂ Montage – Rohr mit hydraulischem Aufweitwerkzeug aufweiten (d50 ... d63)

- → Hydraulikschlauch an Hydraulikaggregat anschliessen.

Aufweitwerkzeug einrichten

- ① → Abstreifringe einsetzen.
② → Aufweitdorn über die Kolbenstange führen.
③ → Rändelschraube handfest anziehen.

⚠ GEFAHR! Verletzungsgefahr durch Fehlbedienung.

→ Werkzeuge nur wie in der Bedienungsanleitung gezeigt handhaben.

- ④ → Spanneinheit über die Gelenkstangen schieben.
→ Nut der Spannbacken gegen die Ringkralle des Arbeitszylinders drücken.
→ Sicherstellen, dass der Aufweitdorn die gleiche Dimension wie die Spannbacken aufweist. Farbkennzeichnung beachten.
⑤ → Vordere Rändelschraube handfest anziehen.

Aufweiten durchführen

- ⑥ → Rohrende bis zum Anschlag in das Aufweitwerkzeug einführen.
→ Sicherstellen, dass das Rohr vor dem Schliessen des Spannehebels parallel in das Aufweitwerkzeug fluchtet.
⑦ → Rohr gegen den Anschlag des Aufweitdorns drücken und Spanneinheit schliessen.

Aufweitvorgang beenden

- ⑧ → Aufweitvorgang durch Drücken der Starttaste am Hydraulikaggregat auslösen.
↳ Der Aufweitvorgang wird mit einem hörbaren „Klack!“ abgeschlossen.
↳ Der Aufweitvorgang ist abgeschlossen, wenn der Aufweitdorn vollständig zurückgefahren ist.
⑨ → Spannehebel öffnen.



Montage – Rohr mit hydraulischem Aufweitwerkzeug aufweiten (d50 ... d63)

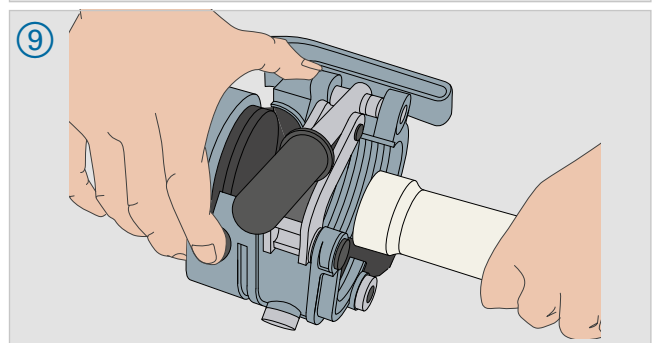
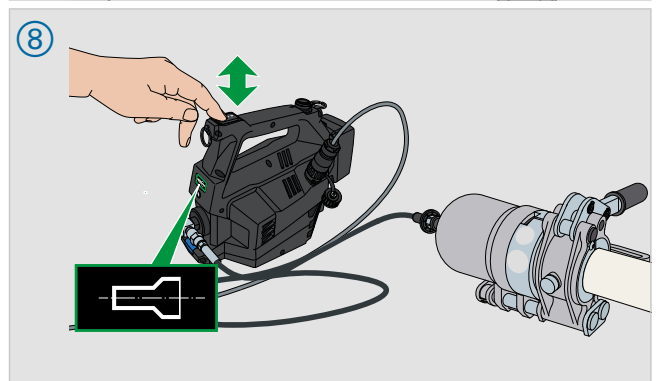
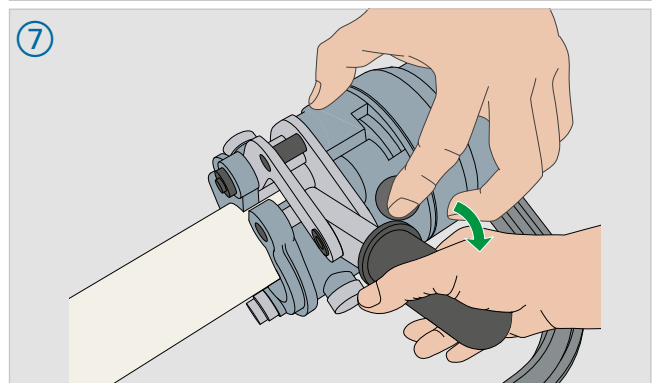
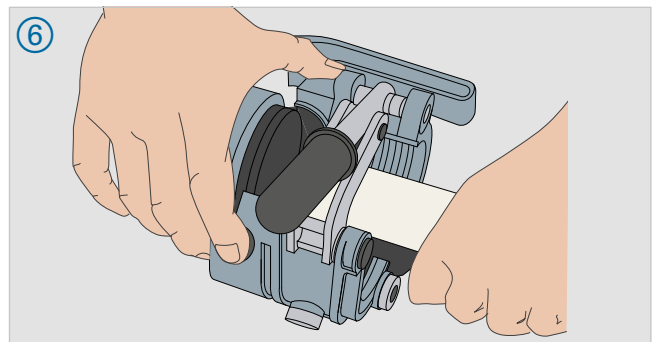
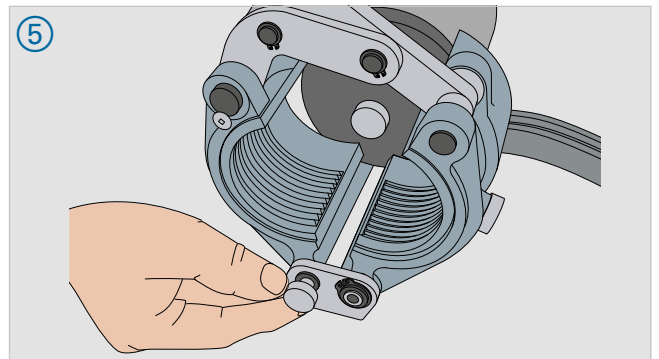
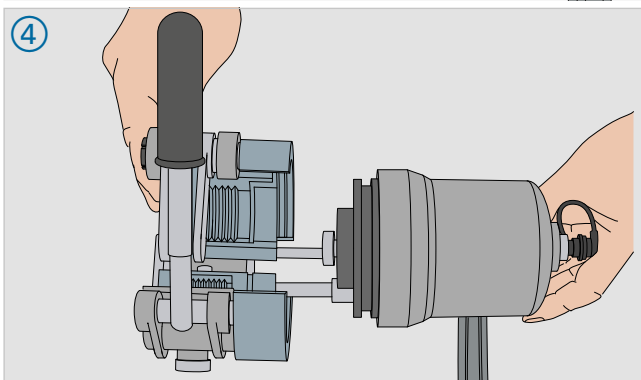
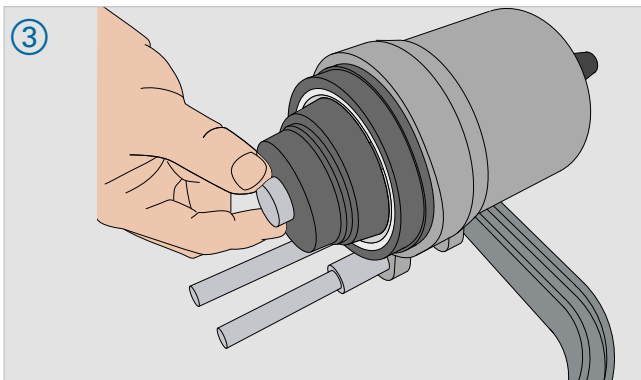
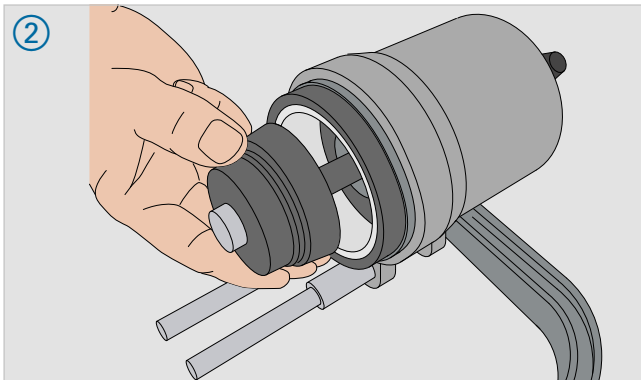
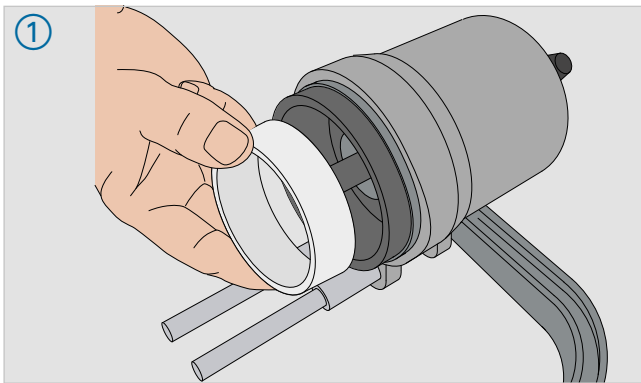

1.6 Montage und Kontrolle

☑ Bedienungsanleitung zum Werkzeug beachten.

Der JRG Sanipex MT-Ratschendrehmomentschlüssel dient ausschliesslich zum Anziehen von JRG Sanipex MT-Bördelklemmverbindern. Die entsprechenden Drehmomente sind werkseitig fest eingestellt.

i Die einzelnen Schritte sind auf der nächsten Seite dargestellt.

✂ Montage - Rohr an Fitting montieren und kontrollieren

Rohr an Fitting montieren

- ① → Aufgebördeltes Rohr auf den Fitting stecken.
- ② → Rohrbördel und Klemmverbindung kontrollieren (d16 bis d63).
 - ↳ Der O-Ring am Fitting muss durch den Rohrbördel **vollständig** verdeckt sein.

! **HINWEIS! Nicht korrekt ausgebildeter Rohrbördel.**

- Nicht korrekt ausgebildete Rohrbördel **nicht** nachbördeln.
- Zu kurze Bördel abschneiden und Vorgang erneut durchführen.

→ Überwurfmutter handfest anziehen.

Verbindung anziehen und kontrollieren

- ③ → Überwurfmutter mit dem Ratschendrehmomentschlüssel bis zum föhl- und hörbaren "Klick" anziehen.
 - Zum Gegenhalten Konterschlüssel am Fitting ansetzen.
- Fertig erstellte Verbindungen mit dem Markierstift markieren.

Bördel kontrollieren

- ④ → Verbindung kontrollieren.
 - Bei d16 bis d40: Schutzfolie abziehen und entsorgen.
 - Bei d50 und d63 beachten:
 - Der Sicherungsring ist sichtbar: Verbindung **nicht** angezogen.
 - Der Sicherungsring ist **nicht** mehr sichtbar: Verbindung angezogen.



Montage - Rohr an Fitting montieren und kontrollieren

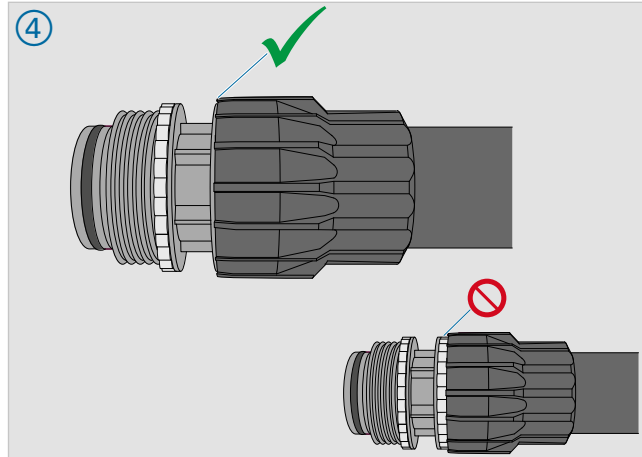
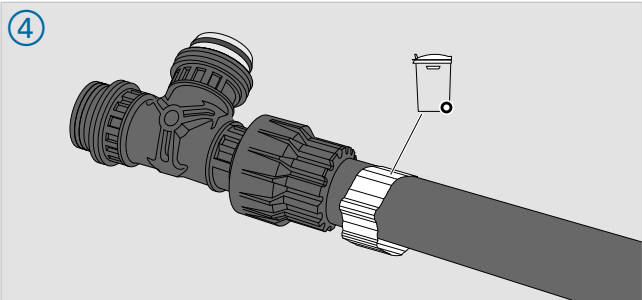
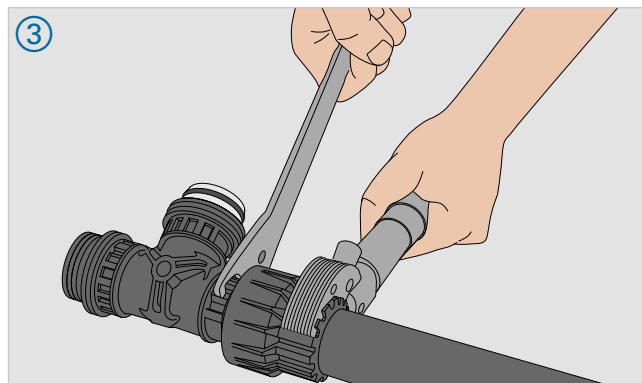
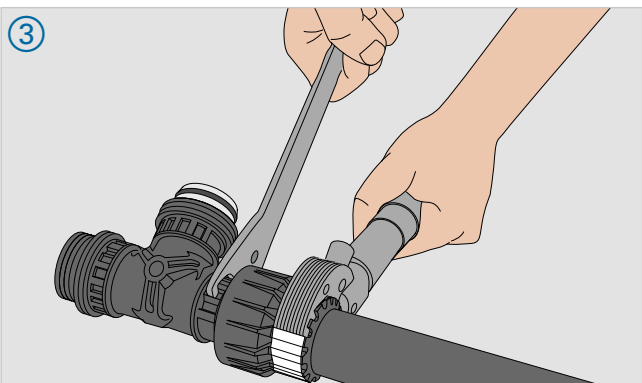
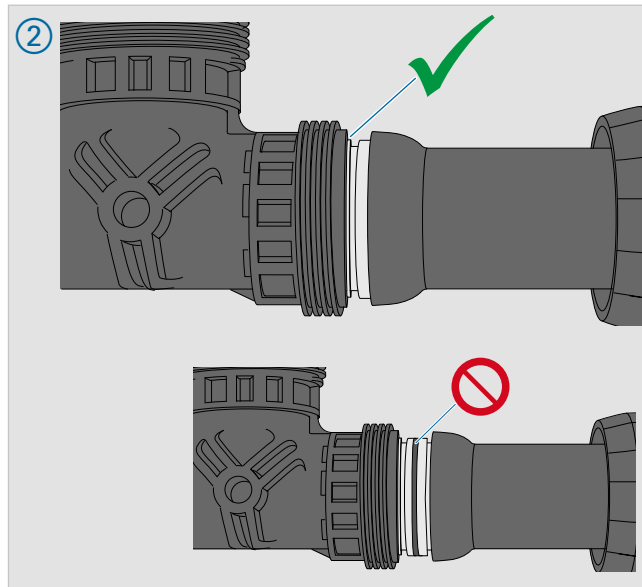
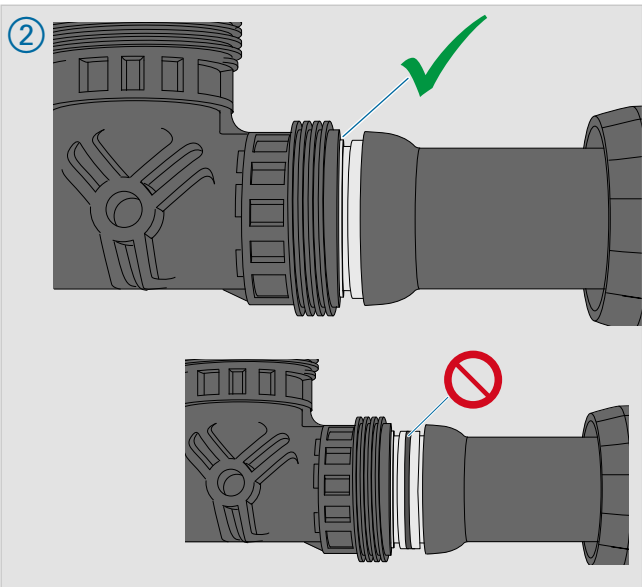
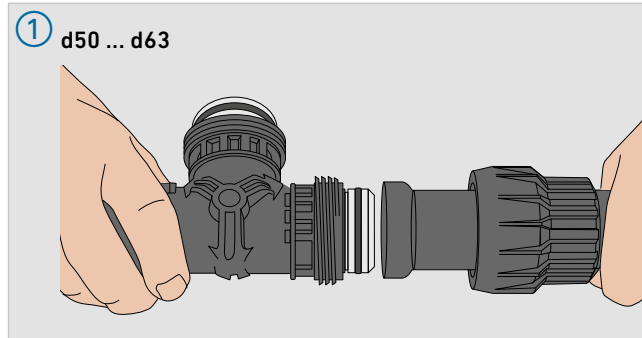
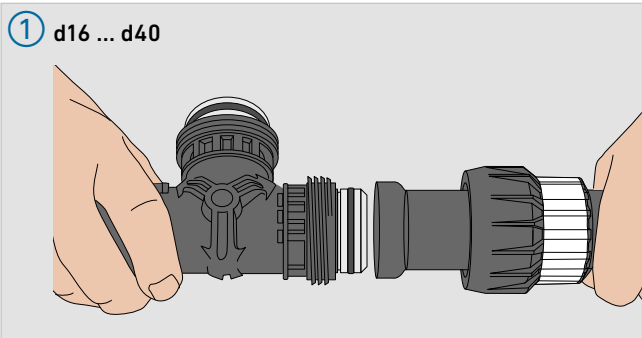

1.7 Biegen mit hydraulischem Biegewerkzeug

- ☑ Bedienungsanleitung zum Werkzeug beachten.
- ☑ Biegebeginn: **Mitte** des Rohrbogens

Masse für Rohrbiegungen: ► Tabelle [TV.25]

TV.20 Biegeanfänge am Rohrbogen

90°-Bogen	45°-Bogen	30°-Bogen
<ul style="list-style-type: none"> → Rohrbogen wie dargestellt anzeichnen. → Mass Mitte-Mitte (bzw. Mitte-Aussen) am geraden Rohrstück anzeichnen. → 1/6 Bogenmass BM* in Richtung Biegeanfang retournessen und anzeichnen. 	<ul style="list-style-type: none"> Durch das Biegen in der Bogenmitte können die geometrisch bedingten Längenänderungen vernachlässigt werden. 	<ul style="list-style-type: none"> Durch das Biegen in der Bogenmitte können die geometrisch bedingten Längenänderungen vernachlässigt werden.

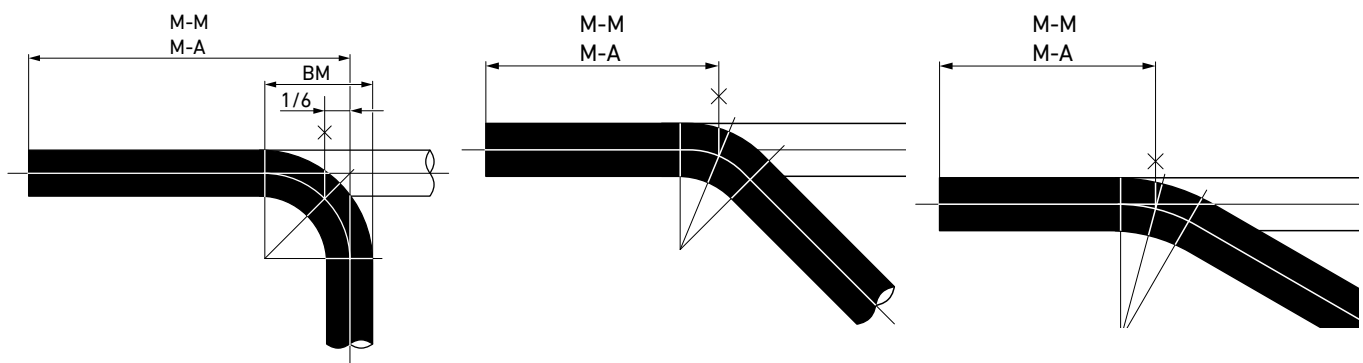

i Die einzelnen Schritte für d26 bis d63 sind auf der nächsten Seite dargestellt.

i Die Abbildungen zeigen die neue Biegeschablone.

✂ Mit hydraulischem Biegewerkzeug biegen

Biegemitte festlegen

- → Rohrbogen wie für den Bogen dargestellt anzeichnen. ► Tab. [TV.27]

Biegewerkzeug einrichten

- ① → Hydraulikzylinder auf die Grundplatte setzen.
- ② → Dimensionsbezogene Skala aufsetzen.
- ③ → Adapternippel einsetzen (nur d26 bis d40).
- ④ → Gewünschte Biegelehre auf die Adapternippel stecken.
- ⑤ → Dorn in Biegerolle einsetzen.
→ Biegerollen in die gewünschte Bohrung einsetzen.
- ⑥ → Hydraulikkupplung an Hydrauliknippel des Bieegeräts anschliessen.
- ⑦ → Steuerkabel des Bieegeräts an die Gerätedose des Hydraulikaggregats anschliessen.

Biegen durchführen

- ⑧ → Biegewinkel festlegen.
→ Schieber auf der entsprechenden Dimension und Winkel einstellen und mit Stell-schraube fixieren.
- ⑨ → Bogenmitte am Rohr anzeichnen. ► Tabelle [TV.26]
→ Rohr in die Biegelehre einlegen. Dabei die Bogenmitte beachten.
☑ Das Rohr muss über die Biegerollen hinausragen.
- ⑩ → Starttaste am Biegewerkzeug drücken und gedrückt halten.
↳ Das Bieegerät führt den Biegevorgang durch.
- ⑪ ↳ Das Bieegerät beendet den Biegevorgang automatisch beim Erreichen des eingestellten Biegewinkels.



Mit hydraulischem Biegewerkzeug biegen (d26 ... d63)

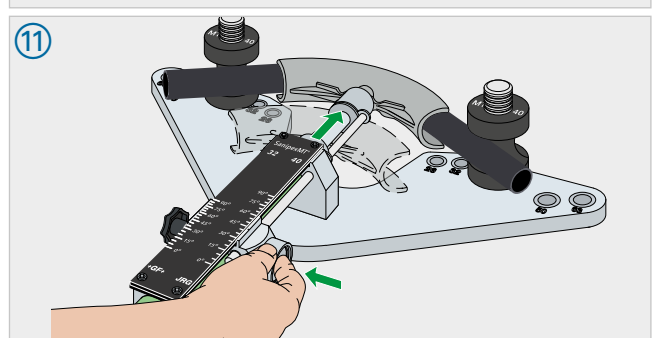
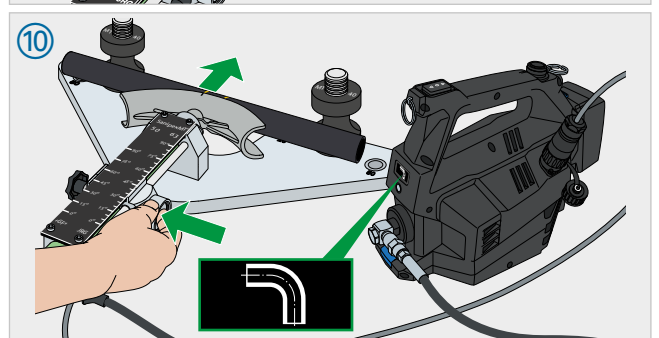
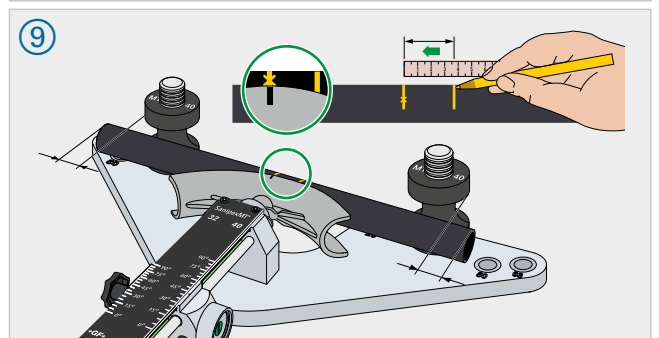
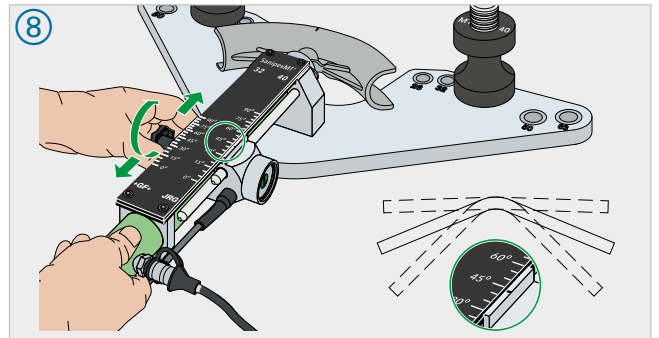
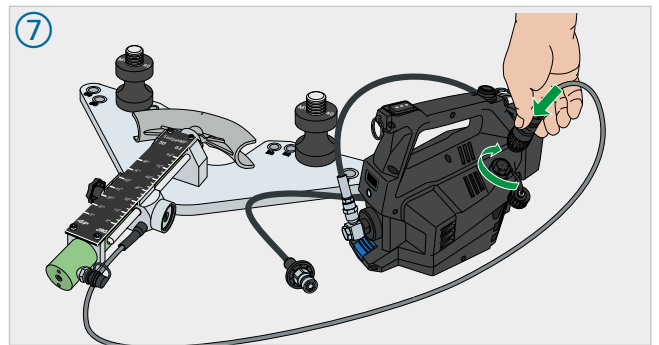
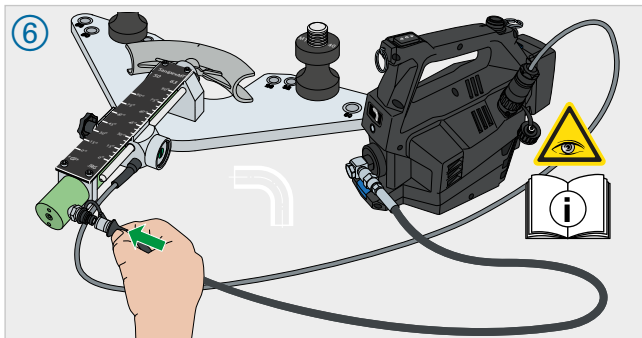
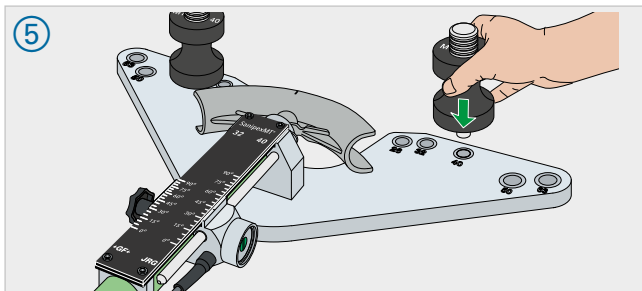
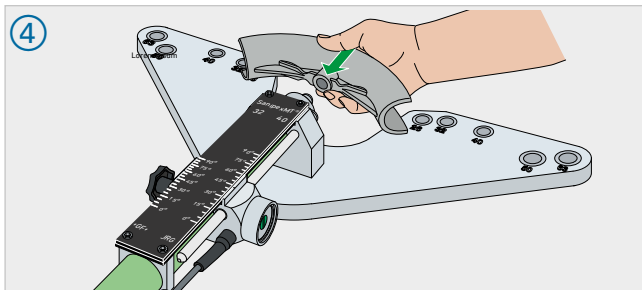
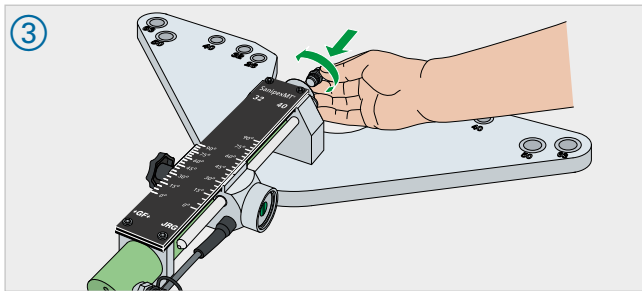
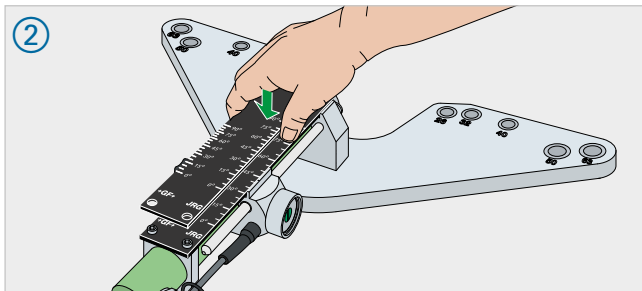
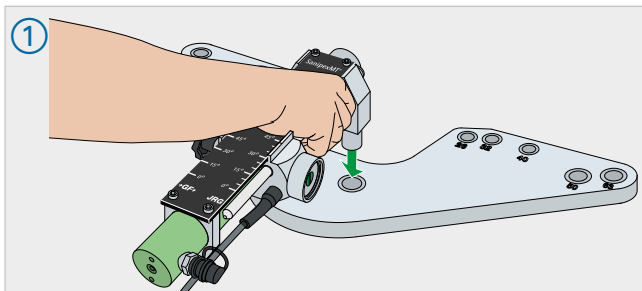

1.1 Battery-operated expanding tool

☑ Observe instruction manual for tool.

Expanding tool together with additional tools is available in a toolbox.

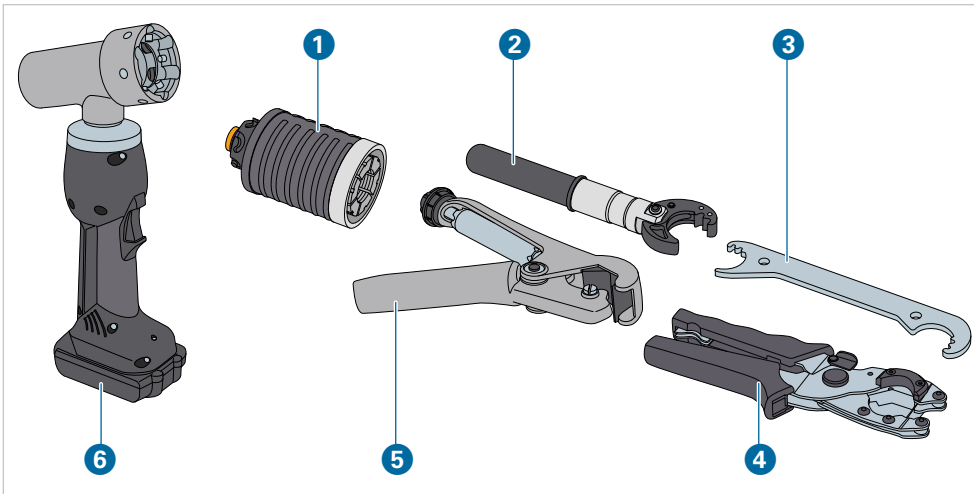

GV.28

Battery-operated expanding tool

- 1 Expander head
- 2 Ratchet torque wrench
- 3 Counter wrench
- 4 Combination shears
- 5 Pipe cutter
- 6 Battery-operated expanding tool

1.2 The Battery- operated Hydraulic Expanding Tool

☑ Observe instruction manual for tool.

The hydraulic expanding tool together with additional tools is available in a toolbox.

Expanding tool (d26 ... d40)

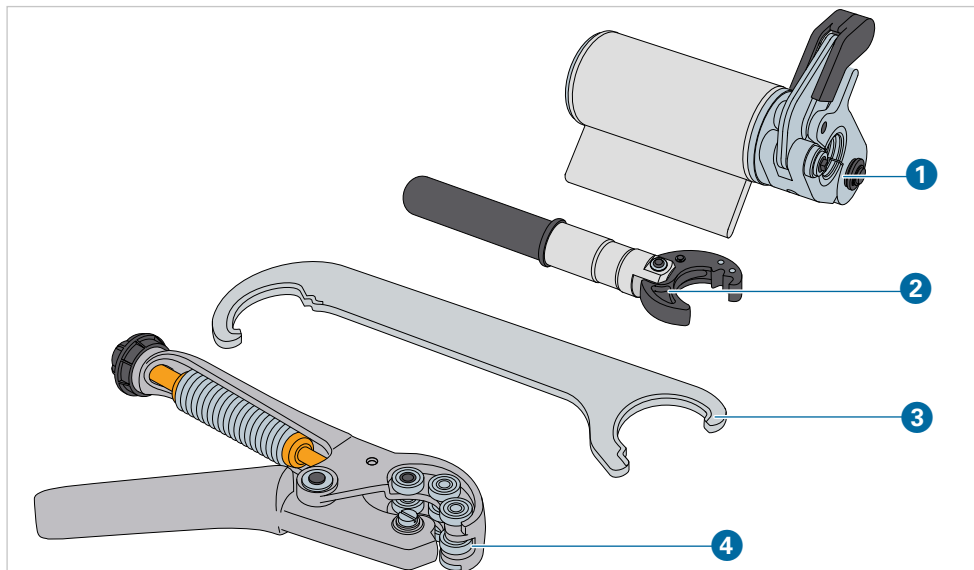

GV.29

Expanding tool d26 ... d40

- 1 Expanding tool
- 2 Ratchet torque wrench
- 3 Counter wrench
- 4 Pipe cutter

Expanding tool (d50 ... d63)

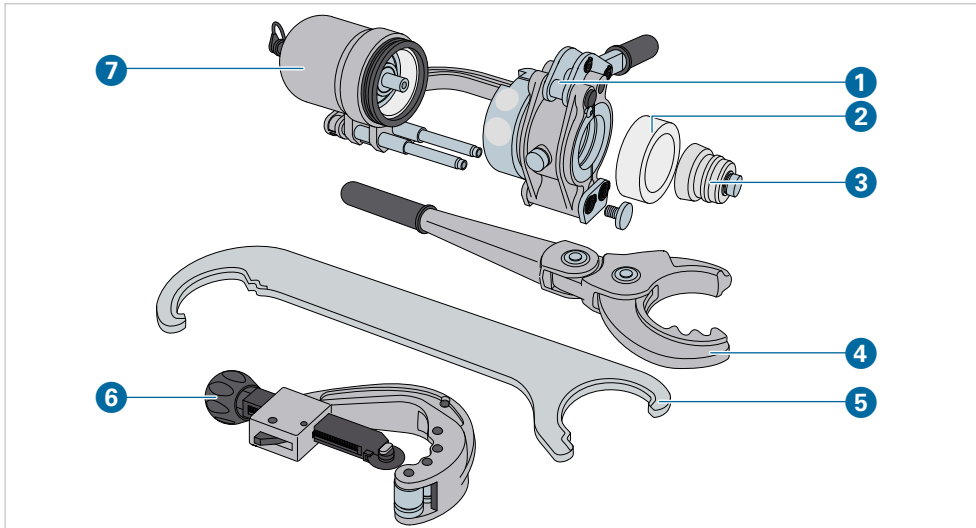

GV.30
Expanding tool d50 ... d63

- 1 Drill clamping unit
- 2 Pipe scraper
- 3 Expanding mandrel
- 4 Ratchet torque wrench
- 5 Counter wrench
- 6 Pipe cutter
- 7 Expanding tool

Battery-operated hydraulic pump

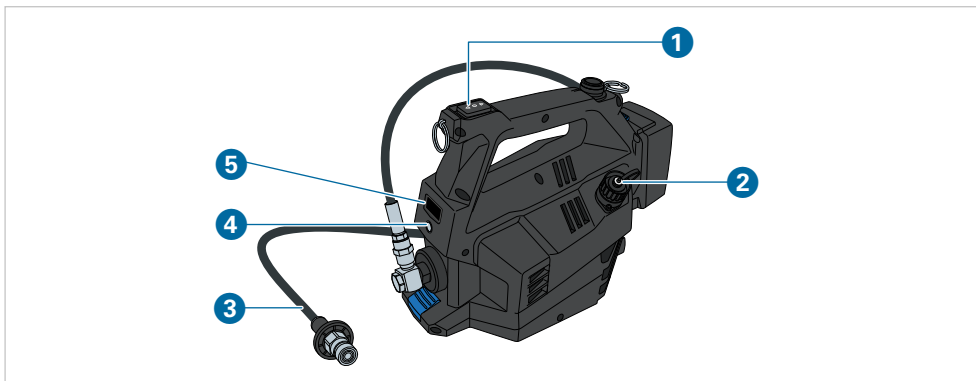

GV.31
Battery-operated hydraulic pump

- 1 Expansion control knob
- 2 Bending tool connection
- 3 Hydraulic hose
- 4 Selector menu
- 5 Display

1.3 Bending tools

Observe instruction manual for tool.

The expanding tool together with additional tools is available in a toolbox.

Bending tool (d16 ... d63)

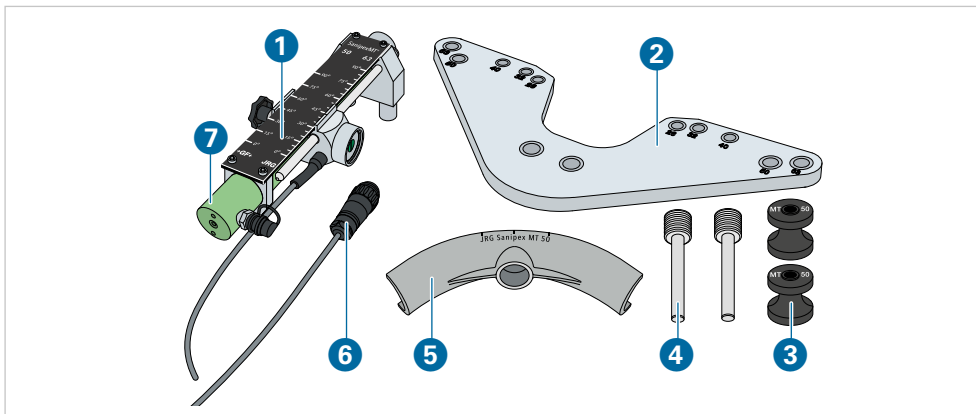

GV.32
Components

- 1 Scale
- 2 Base plate
- 3 Bending rollers
- 4 Fastening bolts
- 5 Bending template
- 6 Control cable
- 7 Cylinder

1.4 Maintenance, Inspection and Service of Tools

A perfectly functioning tool is a basic requirement for a permanently tight connection.

-  **Danger of injury and material damage due to poor maintenance, inspection and service.**
 → Maintain and inspect tools regularly at least at once a year according to information in the operating manual to ensure proper function.

1.5 Expansion with hydraulic expansion tool

- ☑ Observe instruction manual for tool.
- ☑ Make sure that the hydraulic expanding tool works correctly.

1.5.1 Expansion – d26 ... d40

-  **DANGER! Risk of injury as a result of improper handling**
 In the area of the limit stops of the clamping lever, there is a risk of injury as a result of improper handling.
 → When handling the clamping lever, make sure that your fingers are in a safe position.

Assembly – Expansion of Pipe with Hydraulic Expansion Tool (d26 ... d40)

- → Connect hydraulic hose to hydraulic unit.

Performing expansion

- ① → Insert pipe ends into the expansion tool up to the stop.
 → Make sure that the expanding mandrel has the same dimension as the clamping jaws. Pay attention to color coding.
- ② → Press the pipe against the stop of the expanding mandrel and close the clamping unit.
- ③ → Trigger the expansion process by pressing the start button at the hydraulic unit.
 → Hold down the start button until 130 bar have been reached and the expansion process has been completed with an audible "click!".
 ↳ The expansion process is completed once the expanding mandrel has retracted completely.
- ④ → Open clamping lever.
- ⑤ → Remove flanged pipe from the expansion tool.



Assembly – Expansion of Pipe with Hydraulic Expansion Tool (d26 ... d40)

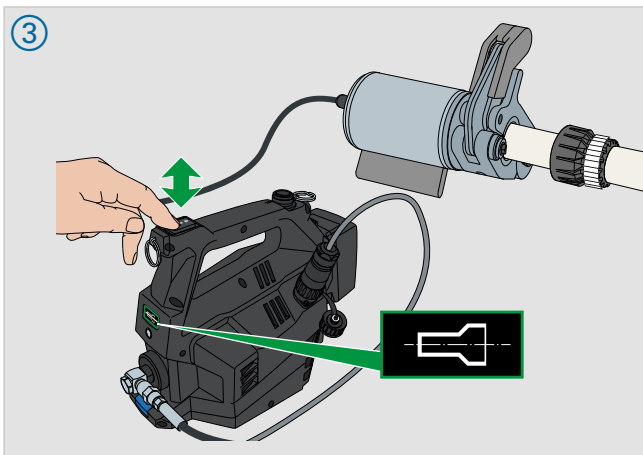
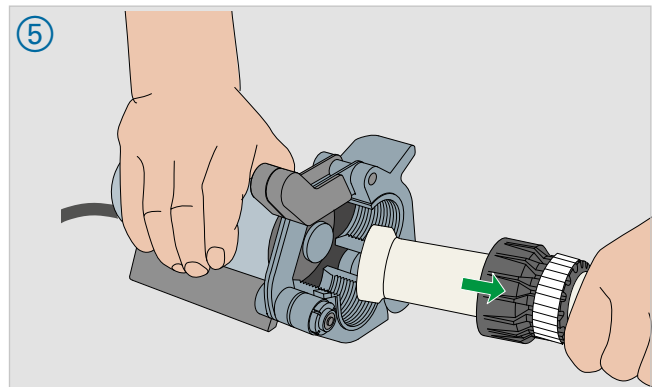
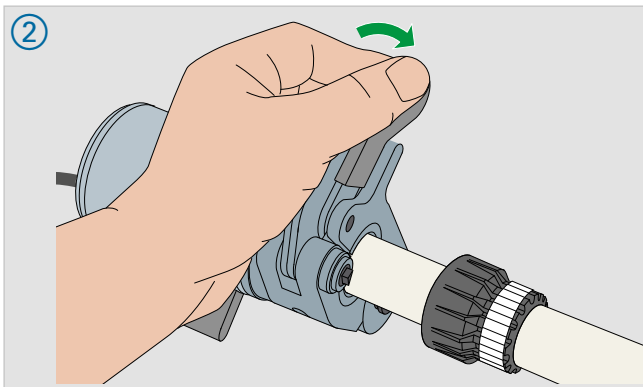
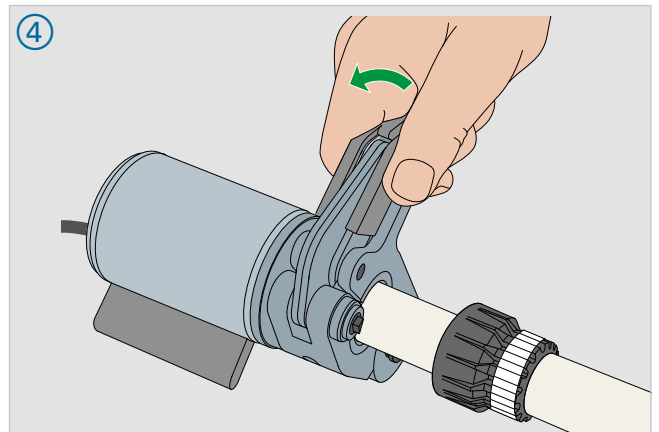
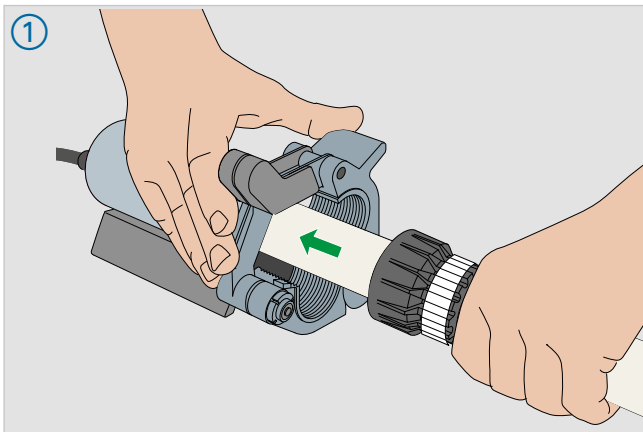

1.5.2 Expansion - d50 ... d63

- !** **NOTE! Incorrect flange length due to chamfering or deburring of the pipe.**
 → Do not chamfer or deburr pipe when cutting to length.

The expansion tool can also be clamped in a vice to facilitate work.

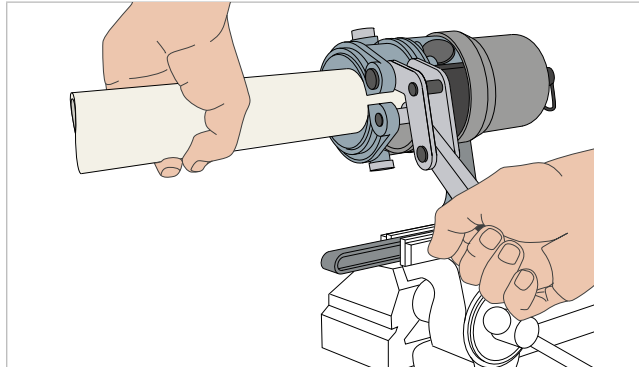

i The individual steps are shown on the next page.

✂ Assembly – Expansion of Pipe with Hydraulic Expansion Tool (d50 ... d63)

- → Connect hydraulic hose to hydraulic unit

Setting up Expanding Tool

- ① → Inserting scraper rings.
- ② → Guide expanding mandrel over the piston rod.
- ③ → Tighten knurled screw by hand.

⚠ **DANGER! Risk of injury as a result of improper handling.**
 → Handle J tools only as shown in the instruction manual.

- ④ → Push clamping unit over the joint rod.
 → Press groove of the clamping jaws against the ring clamp of the work cylinder.
 → Make sure that the expanding mandrel has the same dimension as the clamping jaws. Pay attention to color coding.
- ⑤ → Tighten front knurled screw by hand.

Performing expansion

- ⑥ → Insert pipe ends into the expansion tool up to the stop.
 → Make sure that the pipe aligns parallel in the expansion tool before closing the clamping lever.
- ⑦ → Press the pipe against the stop of the expanding mandrel and close the clamping unit.

Ending the expansion process

- ⑧ → Trigger the expansion process by pressing the start button at the hydraulic unit.
 - ↳ The expansion process is completed with an audible "click!".
 - ↳ The expansion process is completed once the expanding mandrel has retracted completely.
- ⑨ → Open clamping lever.



Assembly - Expansion of Pipe with Hydraulic Expansion Tool (d50 ... d63)

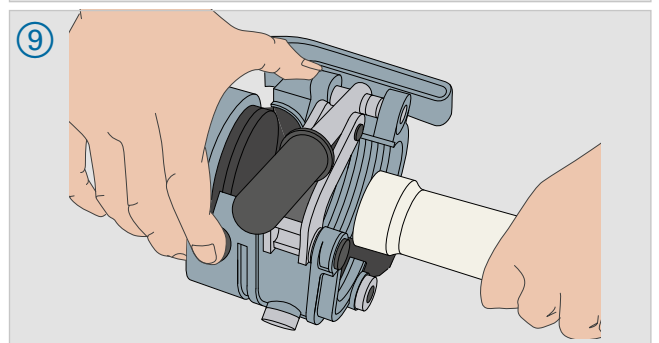
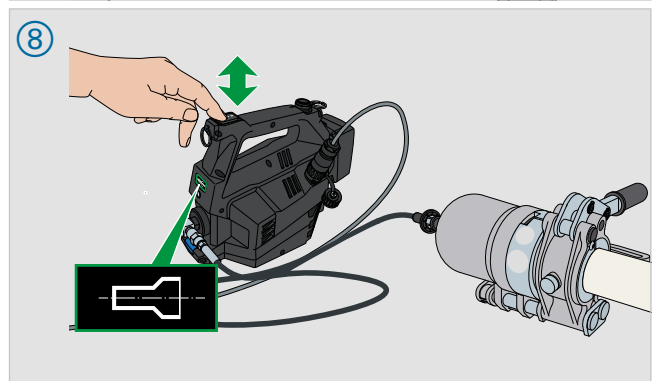
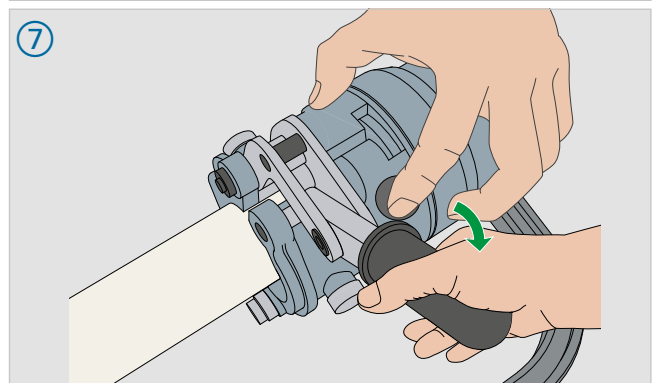
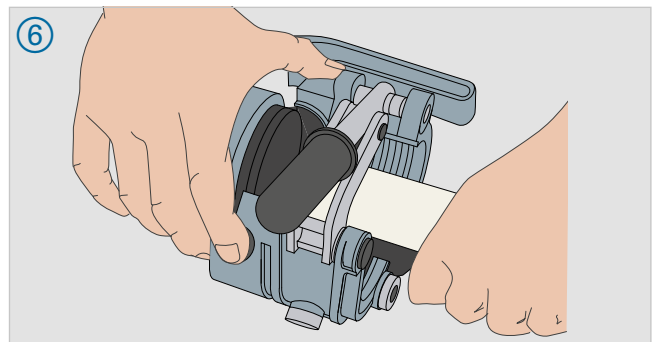
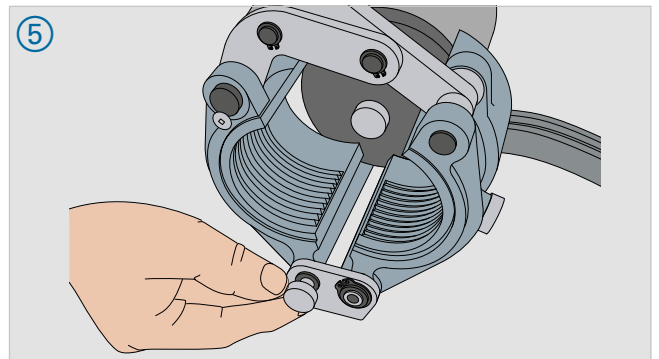
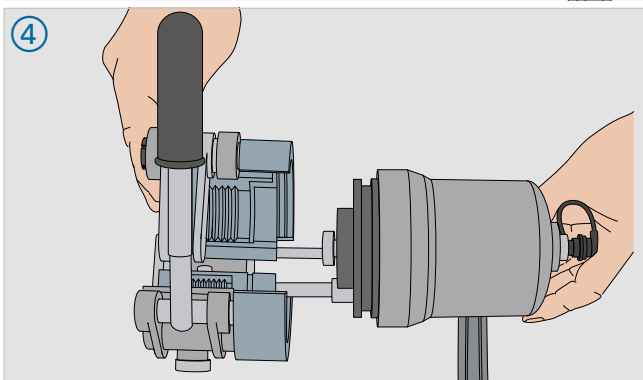
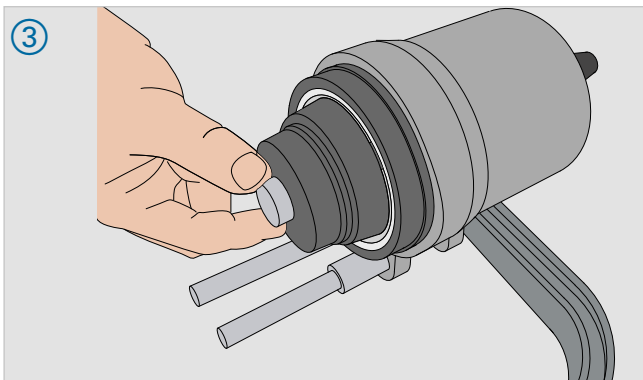
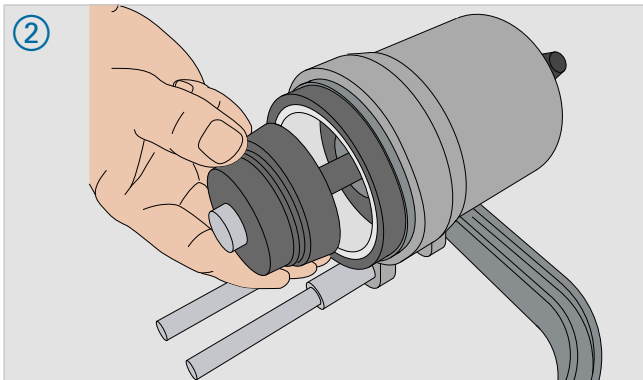
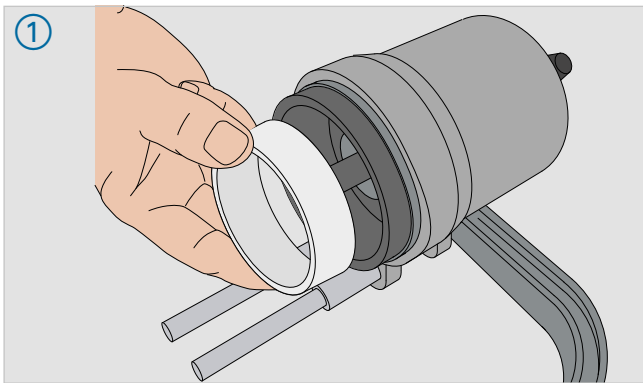

1.6 Assembly and Control

☑ Observe instruction manual for tool

The JRG Sanipex MT ratchet torque wrench is used solely for tightening JRG Sanipex MT flanged clamp connections. The appropriate torque is preset at the factory.

i The individual steps are shown on the next page.

✂ Assembly – Assembling and checking pipe on fitting

Assembling pipe on fitting

- ① → Place flanged pipe onto the fitting
- ② → Check pipe flange and clamp connection (d16 to d63).
 - ↳ The O-ring on the fitting must be covered **completely** by the pipe flange.

! **NOTE! Incorrectly formed pipe flange.**

- Incorrectly formed pipe flanges must not be re-flanged.
- Cut off flanges that are too short and repeat the procedure.

→ Tighten the cap nut by hand.

Tightening and checking connection

- ③ → Tighten cap nut with the ratchet torque wrench until a "click" can be felt and heard.
 - To hold steady, apply the counter wrench on the fitting.
- Mark finished connections with the marker.

Checking pipe flange

- ④ → Check connection.
 - At d16 to d40: Remove and dispose of protective film.
 - At d50 and d63 make sure that:
 - The circlip is visible: connection not tightened.
 - The circlip is no longer visible: connection tightened.



Assembly – Assembling and checking pipe on fitting

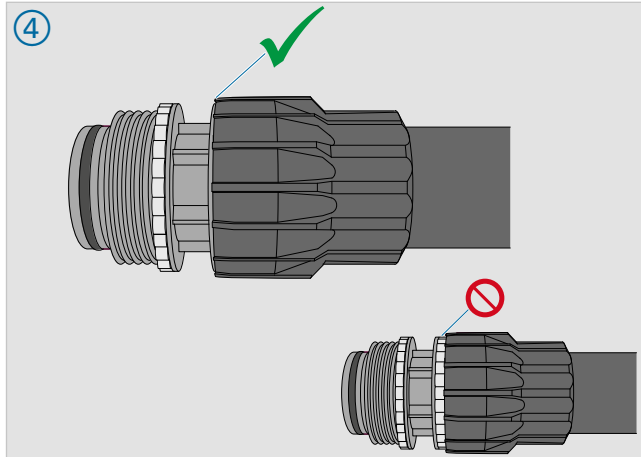
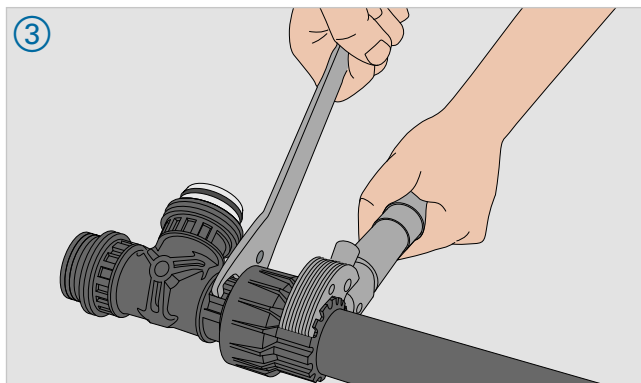
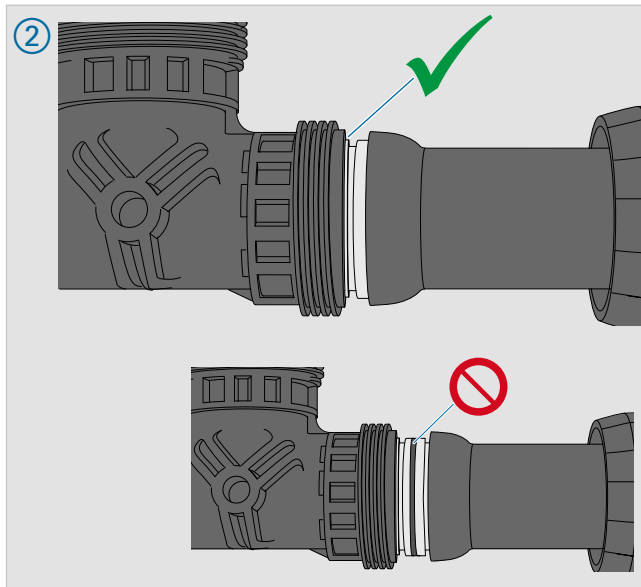
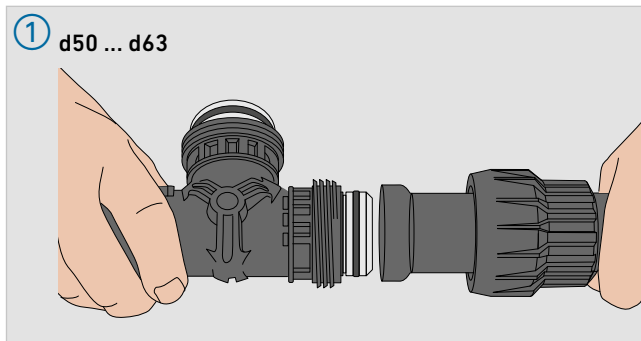
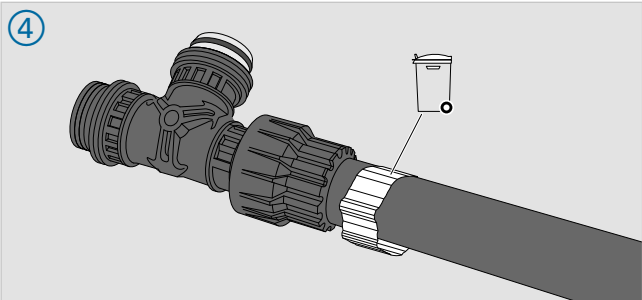
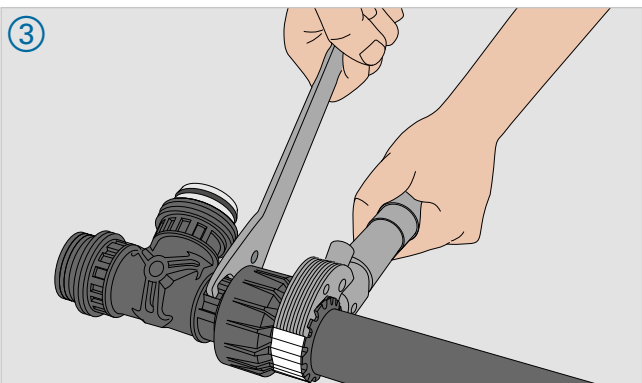
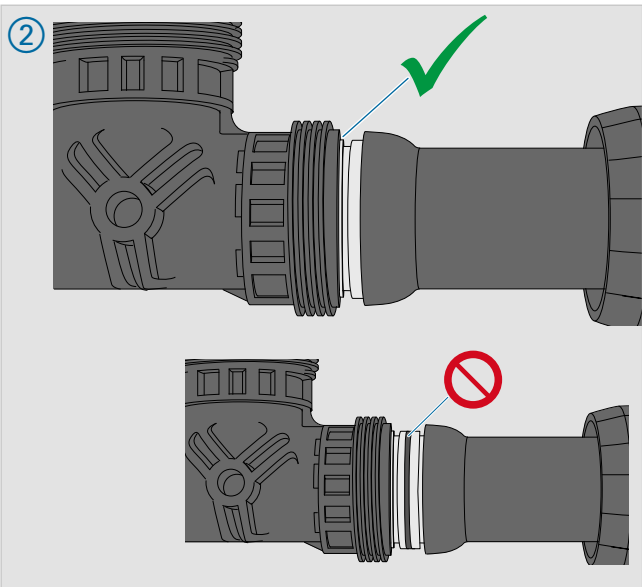
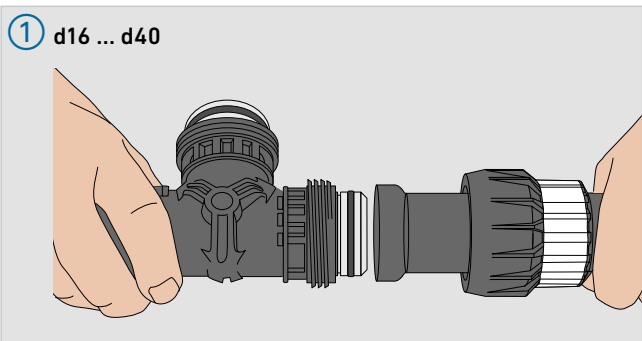

1.7 Bending with Hydraulic Bending Tool

- ☑ Observe instruction manual for tool.
- ☑ Start of bend: **Middle** of the pipe bend section for pipe bends: ➤ Table [TV.25]

TV.21 Bend begins at the pipe bend 90° bend

90° bend	45° bend	30° bend
<ul style="list-style-type: none"> → Mark pipe bend as shown. When bending from the middle of the bend → middle-middle (or middle outer) section, the geometrical changes in length on the straight pipe section can be disregarded. → 1/6 bend section* in direction of bend start, return measure and mark. 	<ul style="list-style-type: none"> When bending from the middle of the bend, the geometrical changes in length can be disregarded. 	<ul style="list-style-type: none"> When bending from the middle of the bend, the geometrical changes in length can be disregarded.

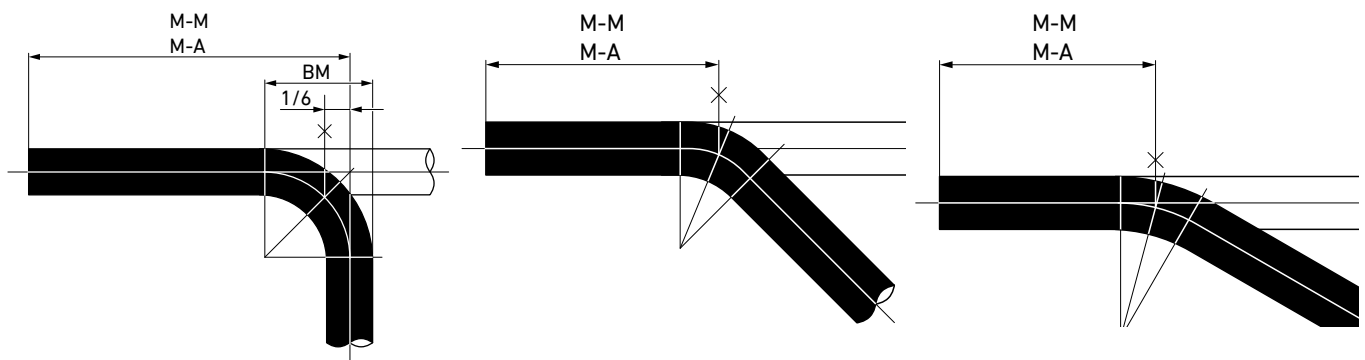

i The individual steps for d26 to d63 are shown on the next page.

i The figures show the new bending template.

✂ Bending with Hydraulic Bending Tool

Determining middle of bend

- → Mark pipe bend as shown for the bend ➤ Tab. [TV.27]

Setting up bending tool

- ① → Place hydraulic cylinder onto the base plate.
- ② → Apply dimension-specific scale.
- ③ → Insert adapter nipple (only d26 to d40).
- ④ → Place required bending gauge onto the adapter nipple.
- ⑤ → Insert mandrel into the bending roller.
→ Insert bending rollers into the required hole.
- ⑥ → Connect hydraulic coupling to hydraulic nipple of the bending tool.
- ⑦ → Connect control cable of the bending tool to the connector socket of the hydraulic unit.

Performing bending

- ⑧ → Specify bending angle.
→ Adjust the slider to the corresponding dimensions and angle and fasten with the positioning screw.
- ⑨ → Mark the middle of the curve on the pipe. ➤ Table [TV.26]
→ Lay the pipe into the bending gauge. When doing so, observe the middle of the curve.
☑ The pipe must protrude over the bending rollers.
- ⑩ → Press and hold down start button on the bending tool
↳ The bending instrument performs the bending procedure.
- ⑪ ↳ The bending instrument finishes the bending procedure automatically once the required bending angle has been reached.



Bending with Hydraulic Bending Tool (d26 ... d63)

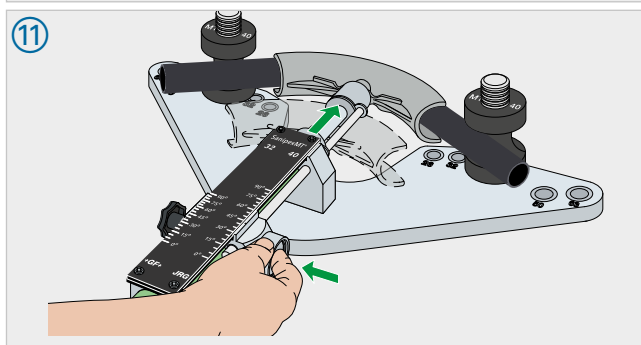
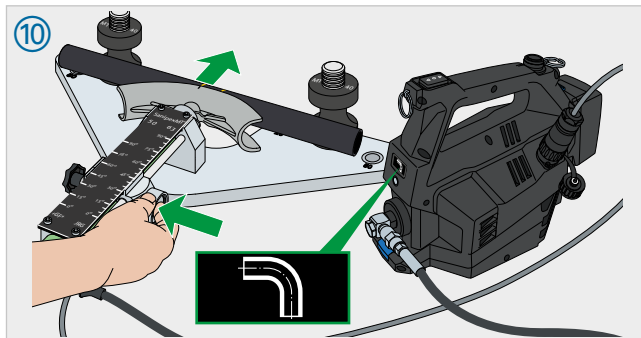
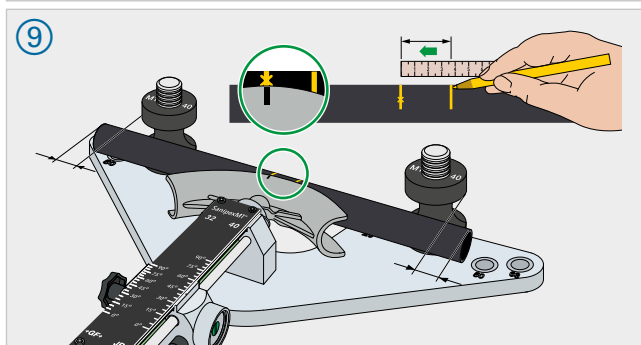
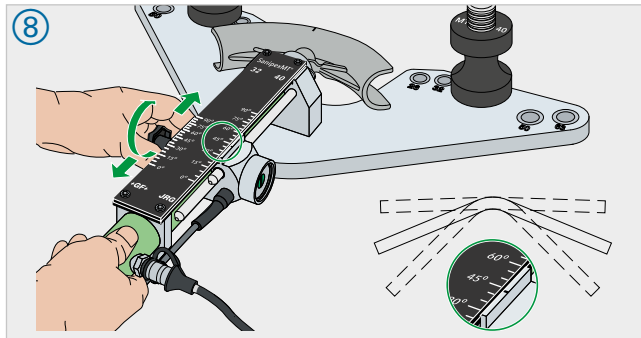
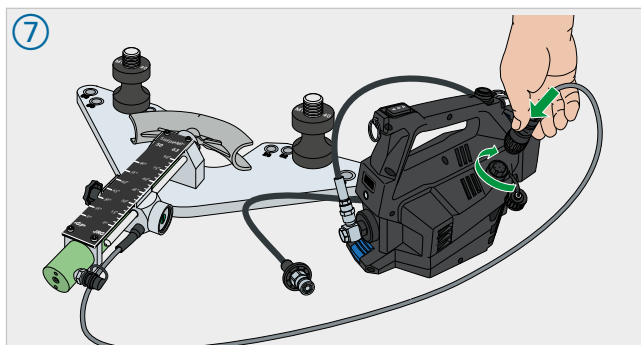
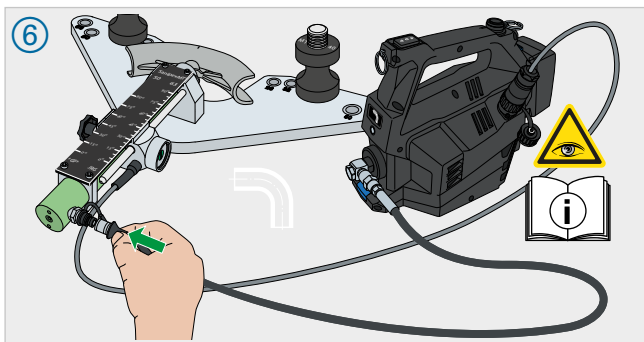
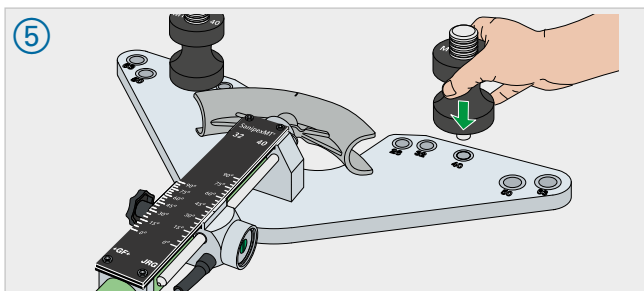
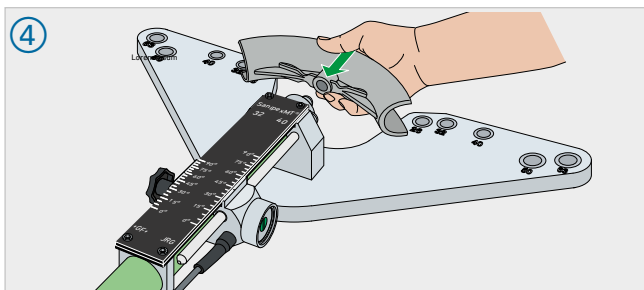
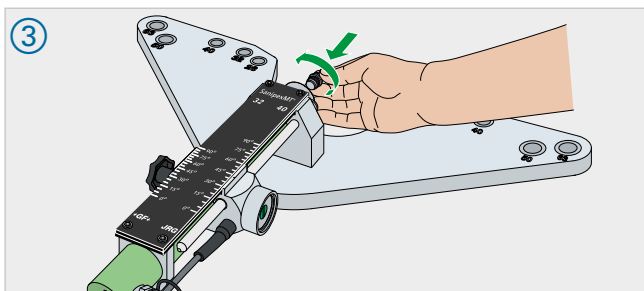
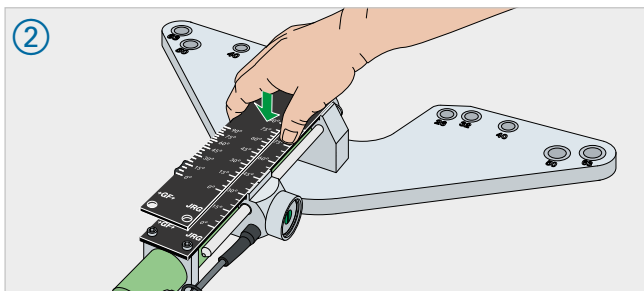
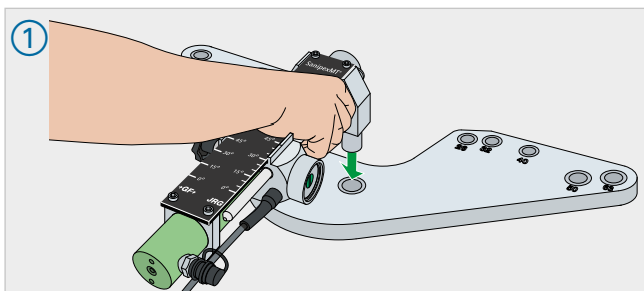

1.1 Utensile di espansione a batteria

☑ Attenersi alle istruzioni per l'uso dell'utensile.

L'utensile di espansione viene fornito in una valigetta insieme ad altri utensili.

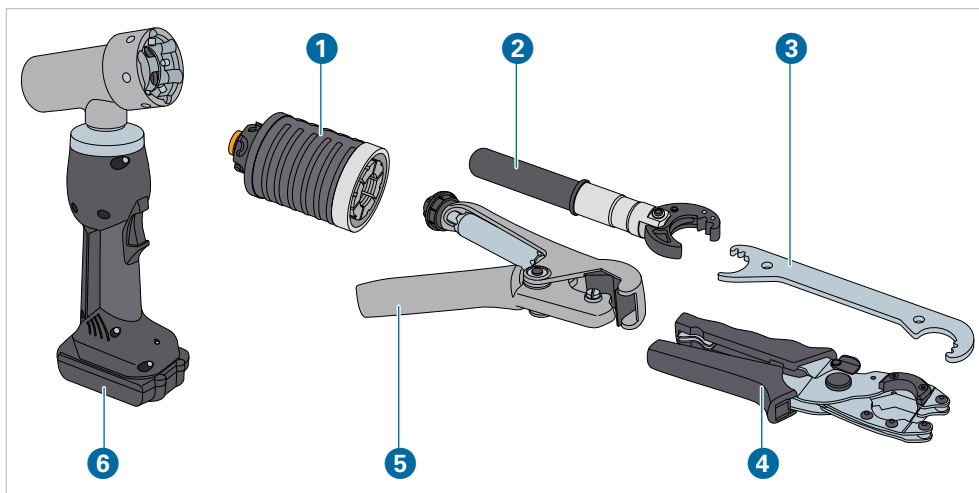

GV.33

Utensile di espansione a batteria

- 1 Testa di espansione
- 2 Chiave dinamometrica a raganella
- 3 Controchiave
- 4 Forbici multiuso
- 5 Tagliatubi
- 6 Utensile di espansione a batteria

1.2 Utensile idraulico di espansione a batteria

☑ Attenersi alle istruzioni per l'uso dell'utensile.

L'utensile idraulico di espansione viene fornito in una valigetta insieme ad altri utensili.

Utensile di espansione (d26 ... d40)

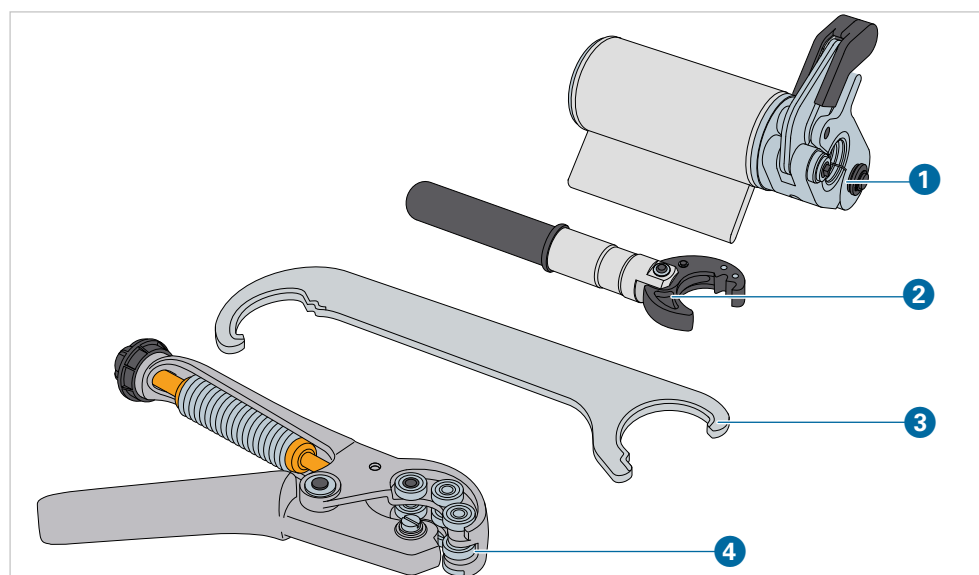

GV.34

Utensile di espansione d26 ... d40

- 1 Utensile di espansione
- 2 Chiave dinamometrica a raganella
- 3 Controchiave
- 4 Tagliatubi

Utensile di espansione (d50 ... d63)

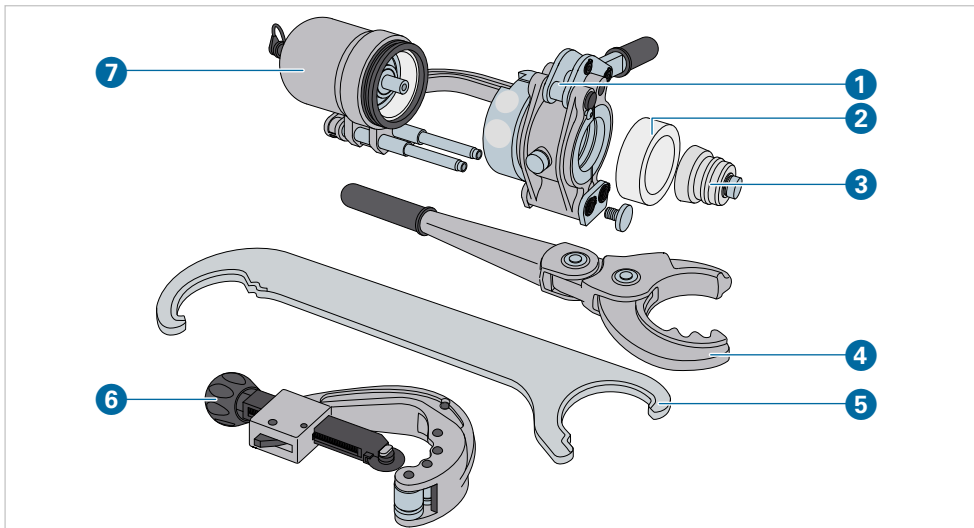

GV.35

Utensile di espansione d50 ... d63

- 1 Unità di serraggio di foratura
- 2 Raschiatore per tubi
- 3 Perno ad espansione
- 4 Chiave dinamometrica a raganella
- 5 Controchiave
- 6 Tagliatubi
- 7 Utensile di espansione

Pompa idraulica della batteria

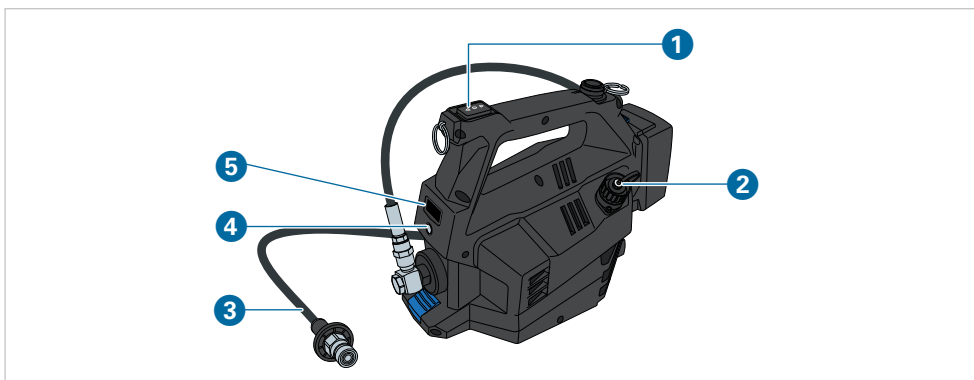

GV.36

Pompa idraulica della batteria

- 1 Manopola Espansione
- 2 Attacco utensile di piegatura
- 3 Tubo idraulico
- 4 Pulsante di selezione Menu
- 5 Display

1.3 Utensili di piegatura

Attenersi alle istruzioni per l'uso dell'utensile.

L'utensile di piegatura viene fornito in una valigetta insieme ad altri utensili.

Utensile di piegatura (d16 ... d63)

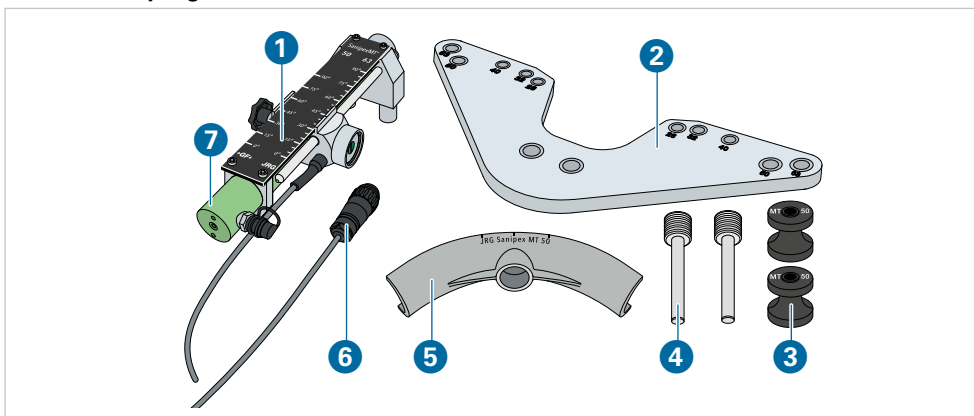

GV.37

Componenti

- 1 Scala
- 2 Piastra di base
- 3 Rulli di piegatura
- 4 Bullone di fissaggio
- 5 Modello di piegatura
- 6 Cavo di comando
- 7 Cilindro

1.4 Cura, controllo e manutenzione degli utensili

Per ottenere un collegamento a tenuta che duri nel tempo, è necessario che l'utensile funzioni alla perfezione.

 **Pericolo di lesioni e danni materiali se si commettono errori di cura, controllo e manutenzione.**

- Effettuare la manutenzione degli utensili come descritto nelle istruzioni per l'uso e controllarne il funzionamento regolarmente, almeno una volta all'anno.

1.5 Espansione con utensile idraulico di espansione

- Attenersi alle istruzioni per l'uso dell'utensile.
- Accertarsi che l'utensile idraulico di espansione funzioni correttamente.

1.5.1 Espansione – d26 ... d40

 **PERICOLO! Pericolo di lesioni in caso di utilizzo scorretto.**

Pericolo di lesioni in caso di utilizzo scorretto nell'area degli arresti della leva di serraggio.

- Quando si maneggia la leva di serraggio, prestare attenzione a mantenere le dita in posizione sicura.

 **Montaggio – Espansione del tubo con utensile idraulico di espansione (d26 ... d40)**

-  → Collegare il tubo idraulico al gruppo idraulico.

Esecuzione dell'espansione

- ① → Inserire l'estremità del tubo nell'utensile di espansione fino a battuta.
 - Accertarsi che il perno di espansione abbia la stessa dimensione della ganascia. Rispettare il contrassegno colorato.
- ② → Spingere il tubo contro la battuta del perno di espansione e chiudere l'unità di serraggio.
- ③ → Innescare la procedura di espansione premendo il tasto di avvio sul gruppo idraulico
 - Tenere premuto il tasto di avvio fino a quando si raggiungono i 130 bar e si sente un clic che indica che la procedura di espansione è terminata.
 - ↳ La procedura di espansione è terminata quando il perno di espansione è tornato indietro completamente.
- ④ → Aprire la leva di serraggio.
- ⑤ → Rimuovere il corrugato dall'utensile di espansione.



Montaggio – Espansione del tubo con utensile idraulico di espansione (d26 ... d40)

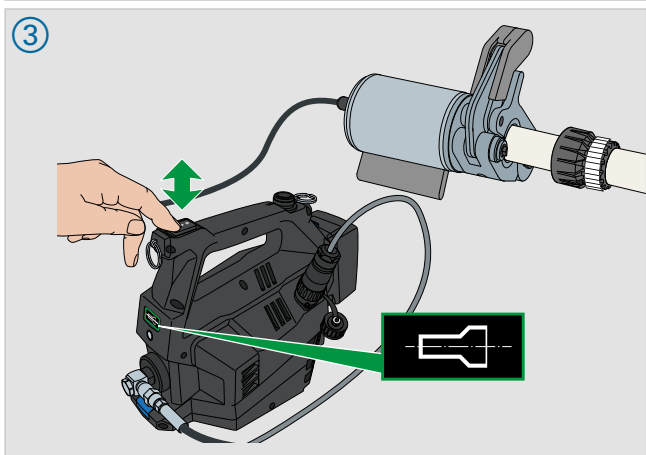
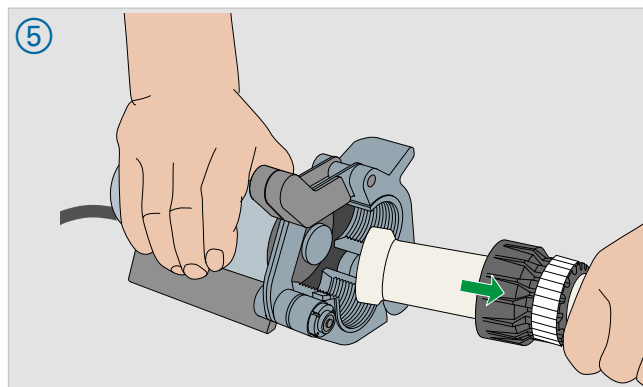
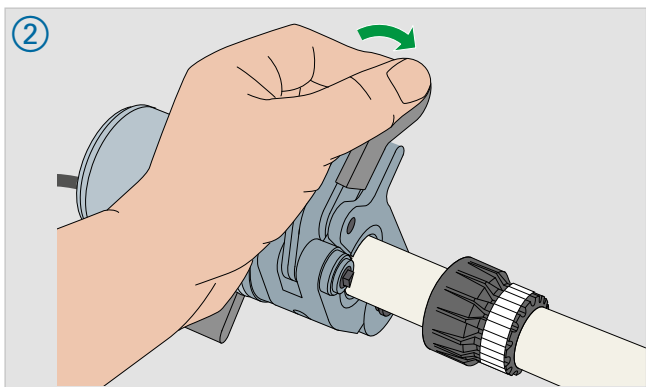
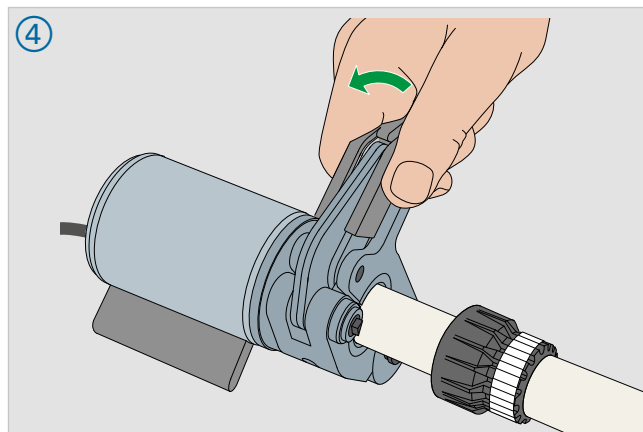
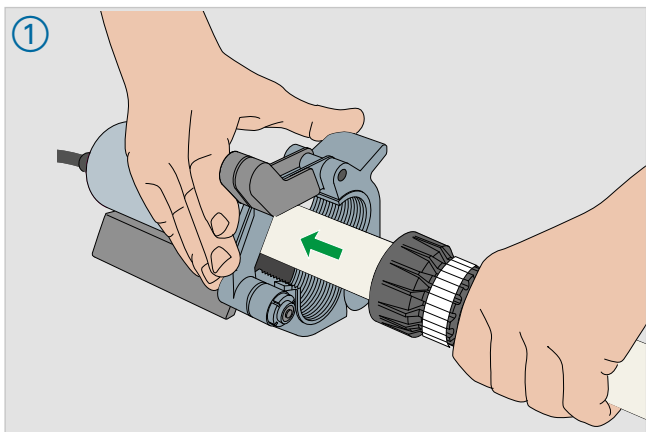

1.5.2 Espansione - d50 ... d63

! **NOTA!** Lunghezza errata del bordo dovuta a smussatura o sbavatura del tubo.

→ Non smussare o sbavare il tubo quando lo si taglia a lunghezza.

Per semplificare il lavoro, si può anche serrare l'utensile di espansione in una morsa a vite.

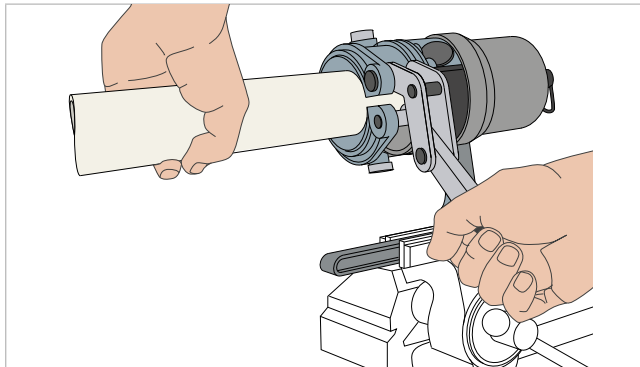

i I singoli passaggi sono raffigurati nella pagina successiva.

✂ Montaggio – Espansione del tubo con utensile idraulico di espansione (d50 ... d63)

○ → Collegare il tubo idraulico al gruppo idraulico.

Regolazione utensile di espansione

- ① → Inserire gli anelli raschiatori.
- ② → Portare il perno di espansione sull'asta del pistone.
- ③ → Serrare energicamente la vite zigrinata.

⚠ PERICOLO! Pericolo di lesioni per utilizzo scorretto

→ Maneggiare gli utensili J solo come indicato nelle istruzioni per l'uso.

- ④ → Spingere l'unità di serraggio sopra alla barra articolata.
- Spingere il dado della ganascia contro la graffa ad anello del cilindro operatore.
- Accertarsi che il perno di espansione abbia la stessa dimensione della ganascia. Rispettare il contrassegno colorato.
- ⑤ → Serrare energicamente la vite zigrinata anteriore.

Esecuzione dell'espansione

- ⑥ → Inserire l'estremità del tubo nell'utensile di espansione fino a battuta.
- Accertarsi che il tubo sia allineato parallelamente all'utensile di espansione prima di chiudere la leva di serraggio.
- ⑦ → Spingere il tubo contro la battuta del perno di espansione e chiudere l'unità di serraggio.

Terminare la procedura di espansione

- ⑧ → Innescare la procedura di espansione premendo il tasto di avvio sul gruppo idraulico.
 - ↳ Un clic indica che la procedura di espansione è terminata.
 - ↳ La procedura di espansione è terminata quando il perno di espansione è tornato indietro completamente.
- ⑨ → Aprire la leva di serraggio.



Montaggio – Espansione del tubo con utensile idraulico di espansione (d50 ... d63)

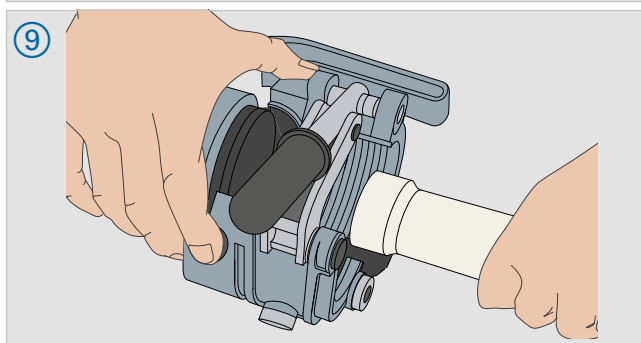
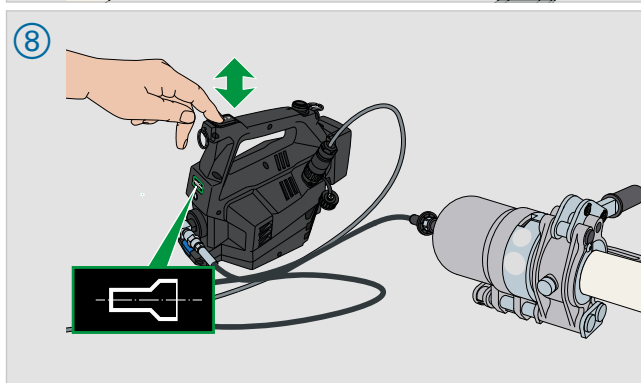
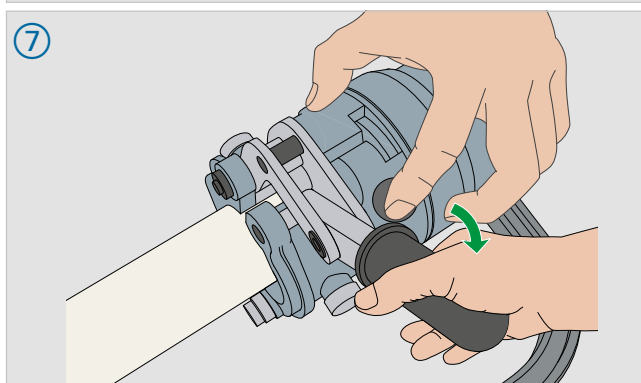
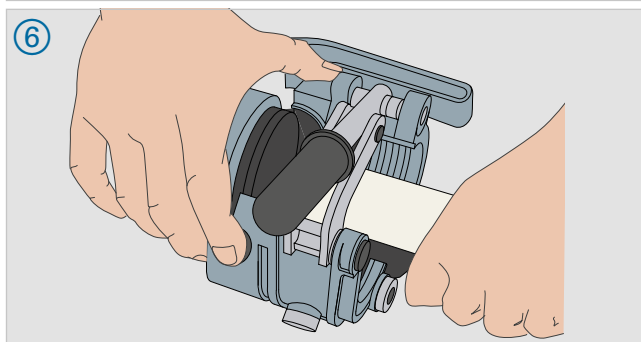
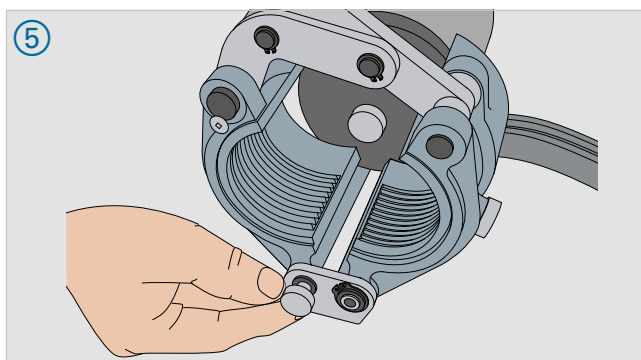
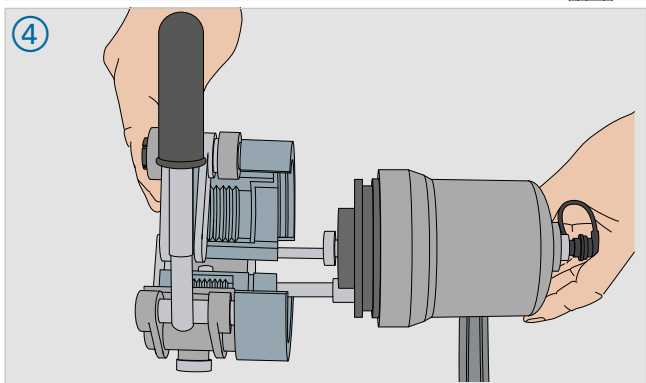
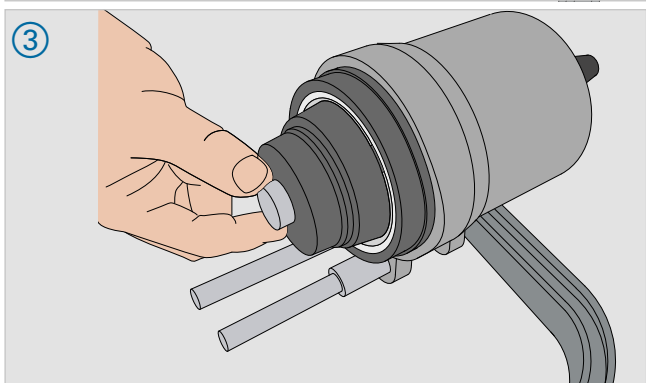
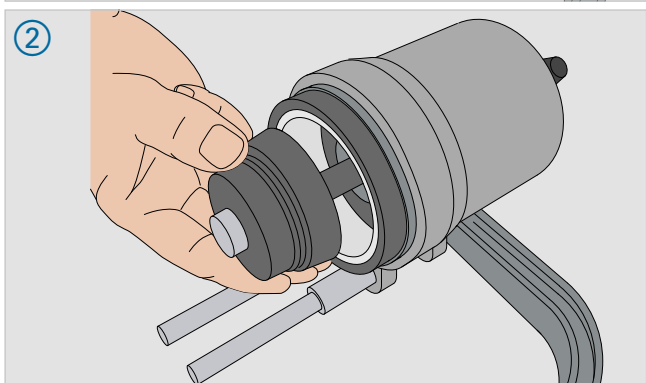
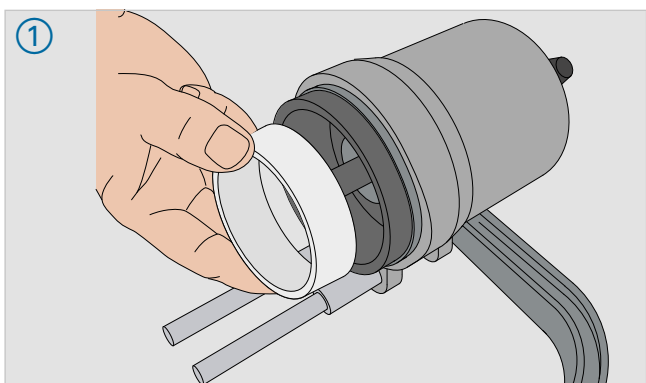

1.6 Montaggio e controllo

☑ Attenersi alle istruzioni per l'uso dell'utensile.

La chiave dinamometrica a raganella JRG Sanipex MT serve esclusivamente al serraggio dei raccordi a morsetto da bordare JRG Sanipex MT. Le relative coppie di serraggio sono tarate in fabbrica.

i I singoli passaggi sono raffigurati nella pagina successiva.

Montaggio – Montaggio del tubo al raccordo e controllo

Montaggio del tubo al raccordo

- ① → Infilare il corrugato nel raccordo.
- ② → Controllare bordo del tubo e collegamento a morsetto (da d16 a d63).
 - ↳ L'o-ring nel raccordo deve essere **completamente** coperto dal bordo del tubo.

! **NOTA! Estremità del tubo non correttamente allargata.**
 → I bordi dei tubi che non sono stati allargati correttamente non possono essere sottoposti a nuovo trattamento.
 → Tagliare i bordi troppo corti e ripetere la procedura.

→ Serrare a mano il dado a risvolto.

Serraggio e controllo del collegamento

- ③ → Serrare il dado a risvolto con la chiave dinamometrica a raganella fino a sentire il "clic".
 - Per tenere fermo, utilizzare la controchiave applicata al raccordo.
- Contrassegnare i collegamenti creati utilizzando un pennarello in feltro.

Controllo dei bordi

- ④ → Controllo del collegamento.
 - Da d16 a d40: togliere la pellicola protettiva e smaltirla.
 - Per d50 e d63:
 - L'anello di sicurezza è visibile: collegamento non serrato.
 - L'anello di sicurezza non è più visibile: collegamento serrato.



Montaggio – Montaggio del tubo al raccordo e controllo

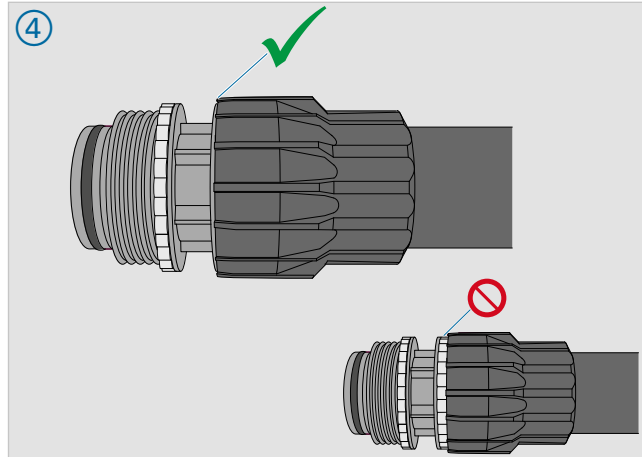
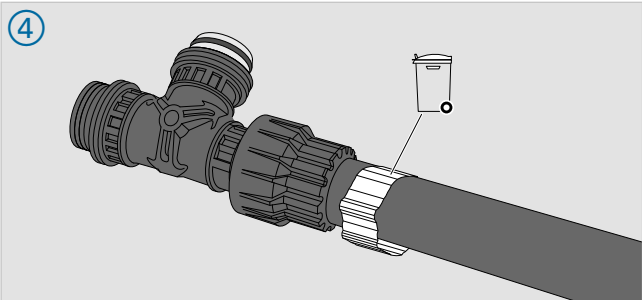
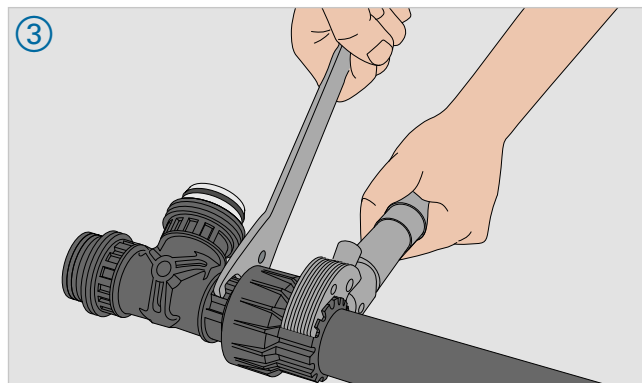
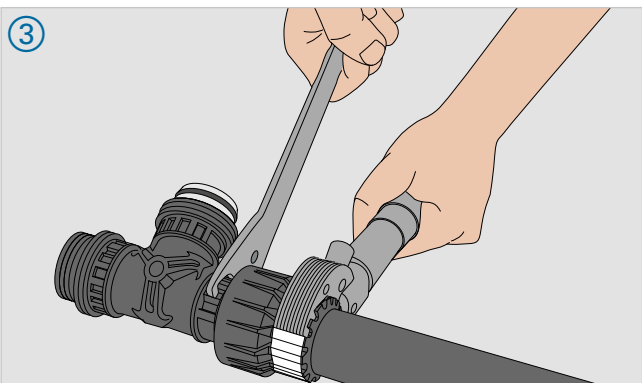
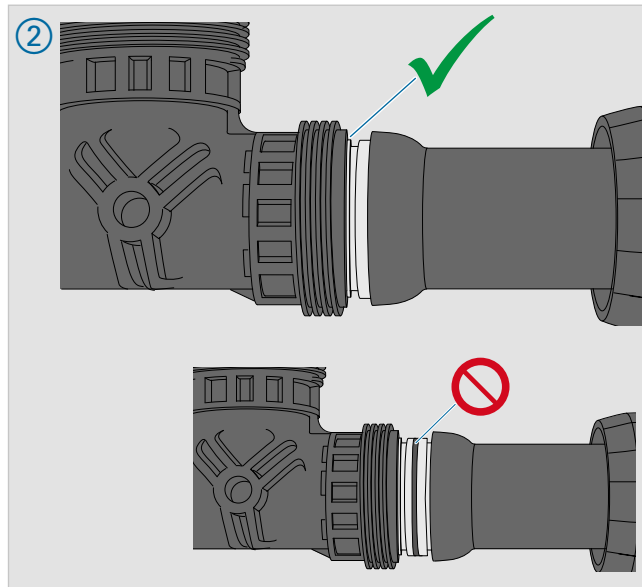
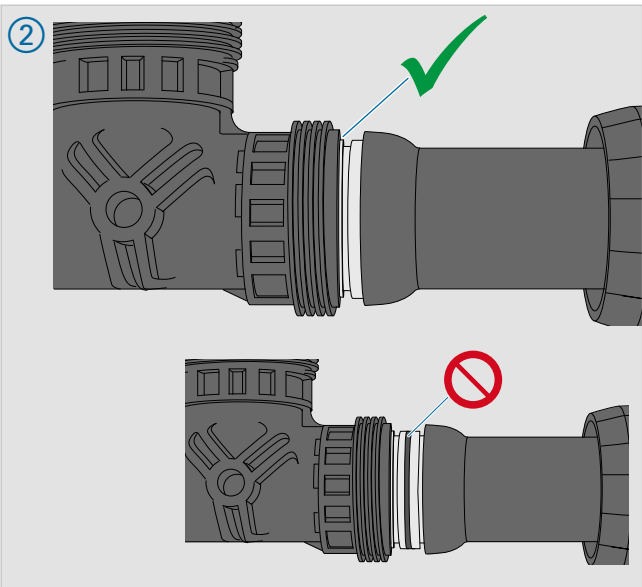
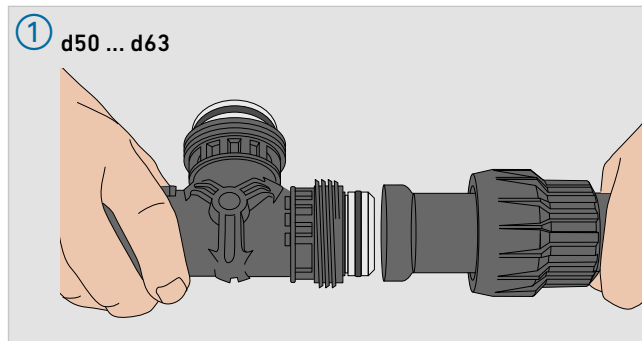
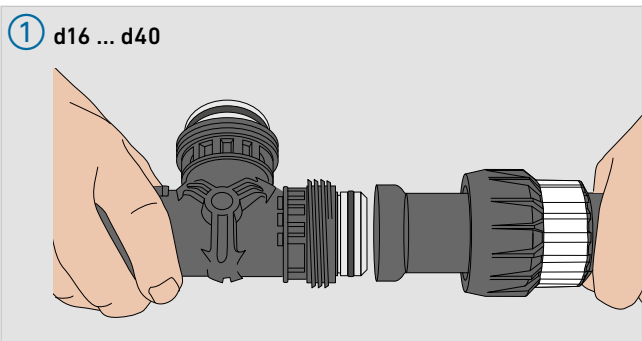

1.7 Piegatura con utensile di piegatura idraulico

- ☑ Attenersi alle istruzioni per l'uso dell'utensile.
- ☑ Inizio della piegatura: **centro** della curva del tubo

misure per piegature del tubo: ► tabella [TV.25]

TV.22 Inizi della piegatura nella curva del tubo a 90°

Curva a 90°	Curva a 45°	Curva a 30°
<p>→ Disegnare la curva del tubo come raffigurato. Piegando al centro della curva.</p> <p>→ Tracciare la misura centro-centro (o centro-esterno) nel pezzo di tubo dritto.</p> <p>→ Trascurare le variazioni di lunghezza.</p> <p>Rimisurare e tracciare 1/6 misura della curva BM* in direzione inizio della piegatura.</p>	<p>Quando si piega al centro della curva si possono trascurare le variazioni di lunghezza dovute a fattori geometrici.</p>	<p>Quando si piega al centro della curva si possono trascurare le variazioni di lunghezza dovute a fattori geometrici.</p>

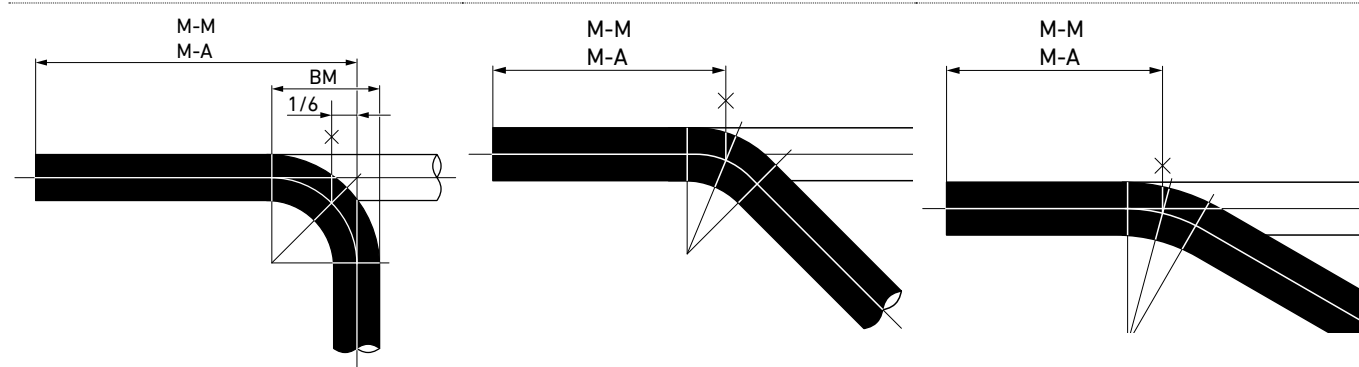

i I singoli passaggi da d26 a d63 sono raffigurati nella pagina successiva.

i Le immagini mostrano la nuova sagoma di piegatura.

✂ Piegatura con utensile di piegatura idraulico

Stabilire il centro della piegatura

- → Tracciare la curva del tubo come raffigurato per la curva. ► Tab. [TV.27]

Messa a punto dell'utensile di piegatura

- ① → Posizionare il cilindro idraulico sulla piastra di base.
- ② → Applicare la scala dimensionale.
- ③ → Inserire il nipplo dell'adattatore (solo da d26 a d40).
- ④ → Applicare la sagoma di piegatura desiderata sul nipplo dell'adattatore.
- ⑤ → Inserire il perno nel rullo di piegatura.
→ Inserire i rulli di piegatura nel foro desiderato.
- ⑥ → Collegare il raccordo idraulico al nipplo idraulico del dispositivo di piegatura.
- ⑦ → Collegare il cavo di comando dell'attrezzo di piegatura alla presa del gruppo idraulico.

Esecuzione della piegatura

- ⑧ → Stabilire l'angolo di piegatura
→ Regolare il cursore al valore corrispondente di dimensione e angolo e fissare con vite di fermo.
- ⑨ → Tracciare il centro della curva sul tubo. ► Tabella [TV.26]
→ Inserire il tubo nella sagoma di piegatura. Rispettare il centro della curva.
☑ Il tubo deve sporgere dai rulli di piegatura.
- ⑩ → Premere il tasto di avvio sull'utensile di piegatura e tenerlo premuto.
↳ Il dispositivo di piegatura esegue la procedura di piegatura.
- ⑪ ↳ Il dispositivo di piegatura termina la procedura di piegatura automaticamente quando raggiunge l'angolo di piegatura impostato.



Piegatura con utensile di piegatura idraulico (d26 ... d63)

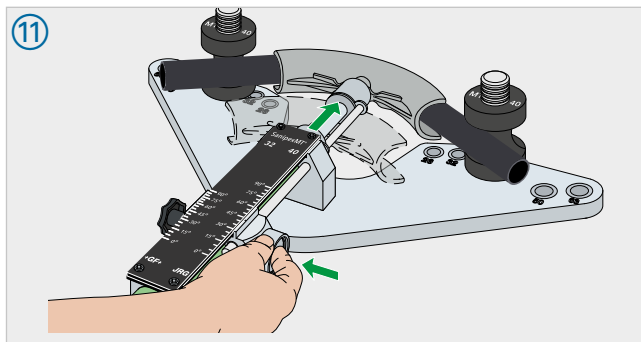
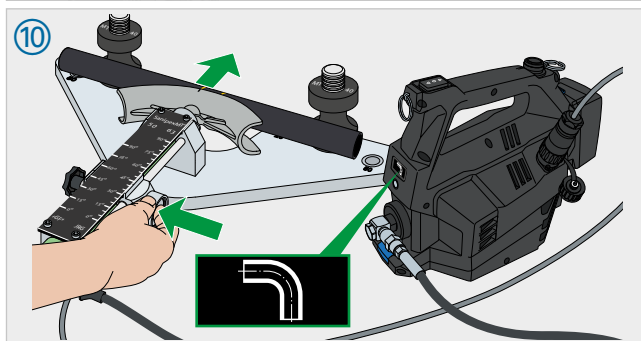
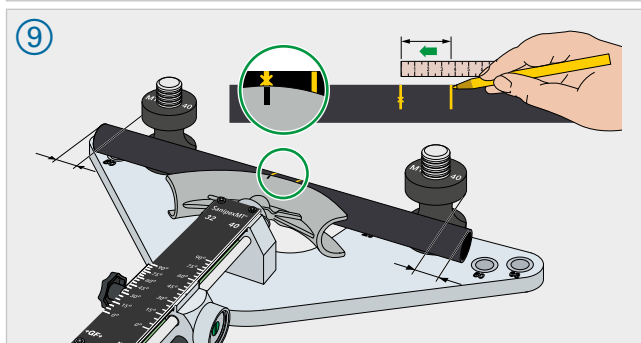
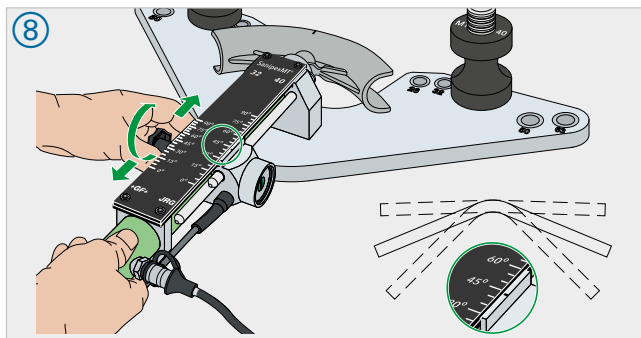
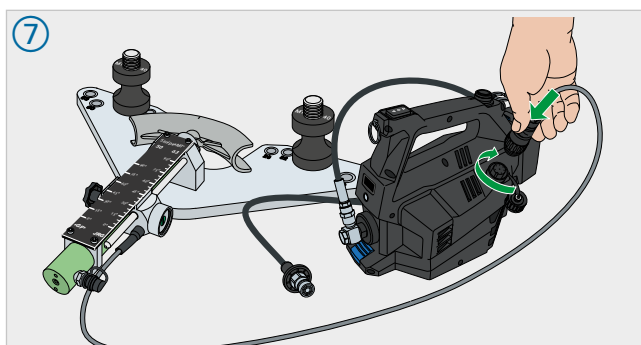
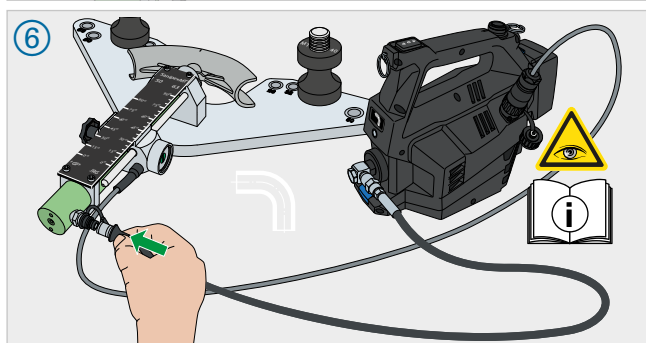
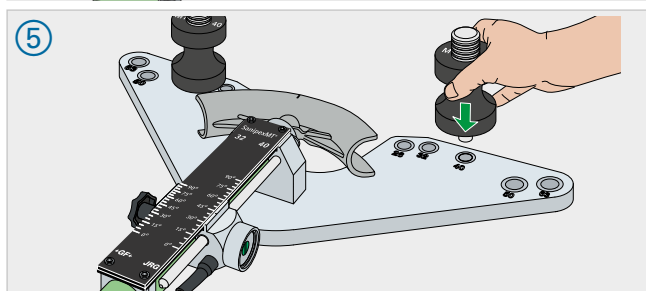
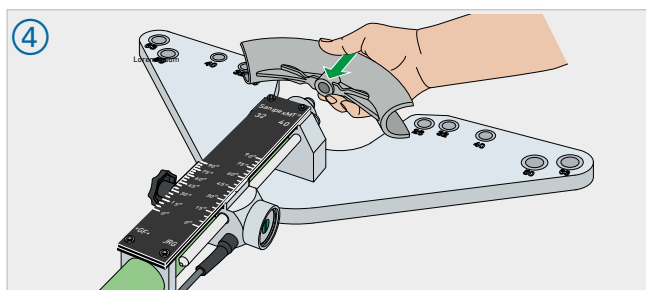
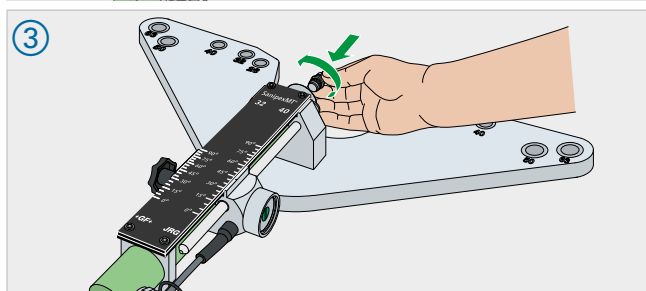
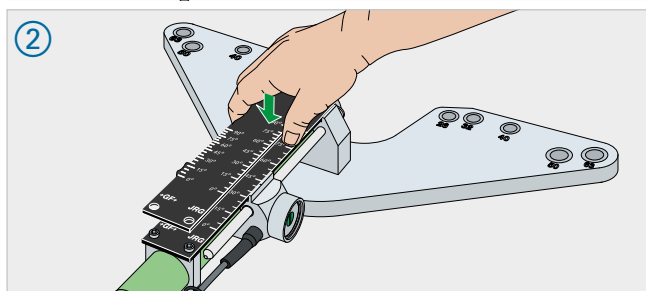
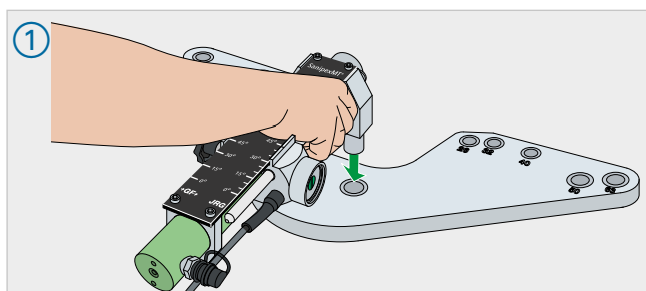

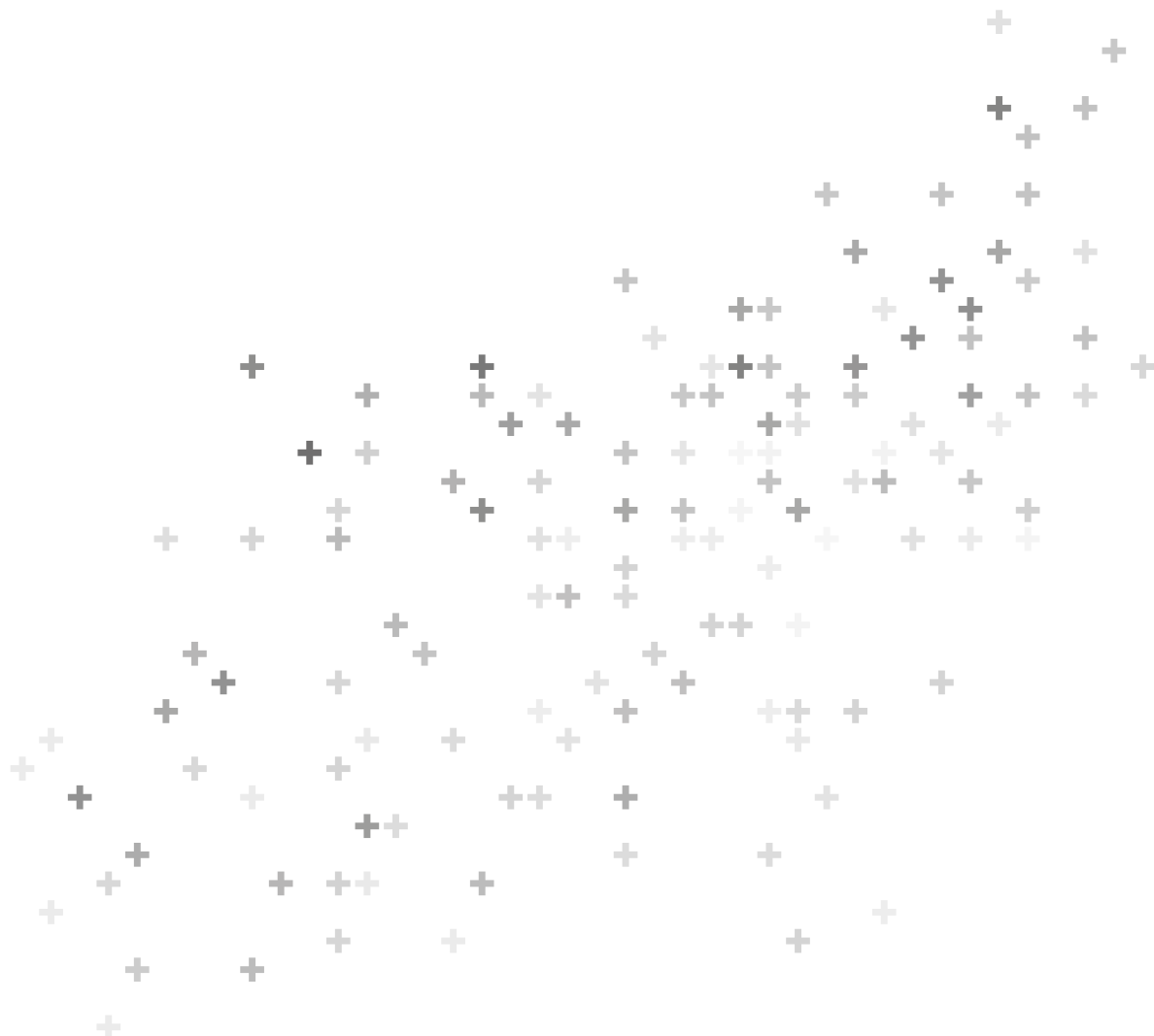

Georg Fischer JRG AG

Hauptstrasse 130, CH-4450 Sissach

Phone +41 (0)61 975 22 22, Fax +41 (0)61 975 22 00

info.jrg.ps@georgfischer.com