

JRG

+GF+

Bedienungs- und Wartungsanleitung

Notice d'utilisation et d'entretien

Istruzioni d'uso e manutenzione

Operating and maintenance instructions

Instrucciones de mantenimiento y funcionamiento

JRGURED

Druckminderer	D	2- 8
Filterreinigung		8
Réducteur de pression	F	9-16
Nettoyage du filtre		16
Riduttore di pressione	I	17-24
Pulizia del filtro		24
Pressure-reducing valve	E	25-32
To clean the filter		32
Válvula reductora de presión	ES	33-40
Limpieza del filtro		40

PN 25 GN 1/2-2 1/2

JRG Code 1300/1303, 1310, 1320, 1330

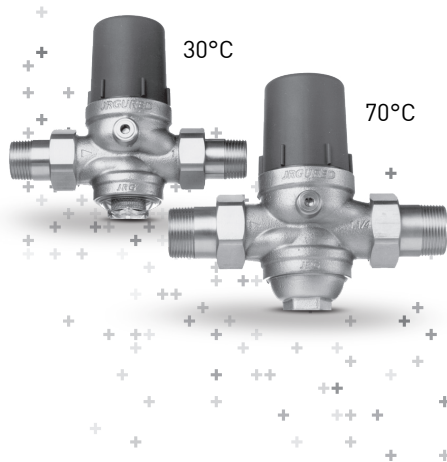

D

Aufbau

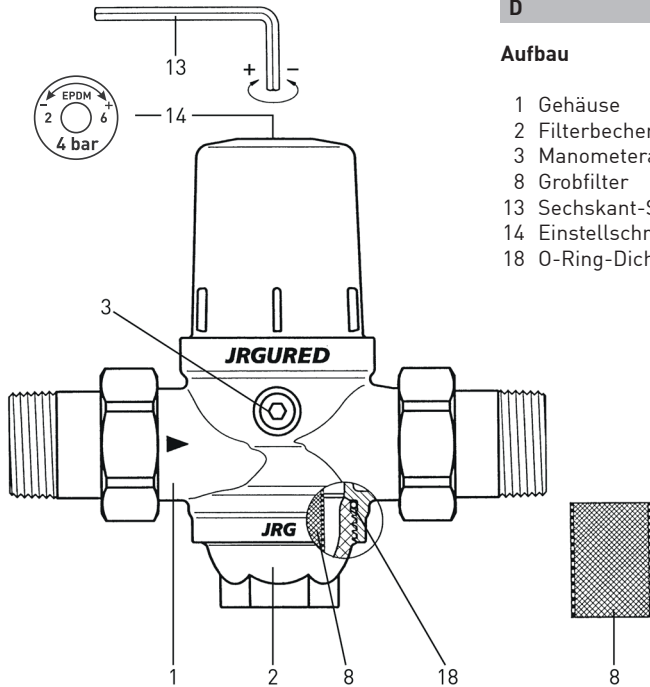

- 1 Gehäuse
- 2 Filterbecher
- 3 Manometeranschluss/Belüftungsschraube
- 8 Grobfilter
- 13 Sechskant-Stiftschlüssel
- 14 Einstellschraube
- 18 O-Ring-Dichtung

Bedienungs- und Wartungsanleitung

Bitte lesen Sie die vorliegende Bedienungs- und Wartungsanleitung aufmerksam durch.

Die eingesetzten Symbole bedeuten:



Gefahr

Dieses Symbol weist auf ein hohes Verletzungsrisiko für Personen hin. Es muss zwingend beachtet werden.



Warnung

Dieses Symbol weist auf eine Information hin, deren Nichtbeachtung zu umfangreichen Sachschäden führen kann. Die Sicherheitshinweise sind zu beachten.



Hinweis

Dieses Symbol weist auf eine Information hin, die wichtige Angaben hinsichtlich der Verwendung enthält. Das Nichtbefolgen kann zu Störungen führen.

Einleitung

Der Druckminderer **JRGURED** ist eine kompakte Armatur für Wasserinstallationen*, bestehend aus Grobfilter und Druckminderer.

* Andere Anwendungen auf Anfrage.

Funktion

Wasserdrücke aus dem Versorgungsnetz müssen, je nach Anlage, auf einen zulässigen Druck reduziert werden.

Der Druckminderer **JRGURED** reduziert den Vordruck auf einen niedrigeren, konstanten Nachdruck.

Der vor dem Druckminderer serienmässig eingebaute Grobfilter hält Schwebestoffe, die grösser als 1'000 µm sind, zurück. Bei Bedarf oder bei merkbarem Druckabfall während der Wasserentnahme ist der Grobfilter zu reinigen.



Da Trinkwasser ein Lebensmittel ist, ist der Grobfilter sowie der Filterbecher auch nur mit solchem, ohne Zusatz von Reinigungsmitteln, zu reinigen. Die nachfolgende Wartungsanleitung ist dabei einzuhalten.

Empfehlung

Schwebestoffe wie Kalk, Rost, Sand usw. können aufgrund von Reparaturen, Sanierungen etc. am öffentlichen Versorgungsnetz über die Gebäude Anschlussleitung in das Hauswasser-Leitungsnetz gelangen.

Um den Druckminderer **JRGURED** wie auch das gesamte Hauswassernetz vor solchen Verunreinigungen zu schützen, empfehlen wir, vor dem Druckminderer einen JRG Feinfilter (1830–1846 oder 1870) mit einer Filtereinheit von 100 µm einzubauen.

Hinweise



Am Druckminderer **JRGURED** dürfen keine Reparaturen vorgenommen werden.



Allfällige Druckumstellungen sind ausschliesslich durch einen Sanitär-fachmann, gemäss der nachfolgenden Bedienungsanleitung, auszuführen.



Für die Wartung des Grobfilters ist die Wartungsanleitung zu beachten.

Die Bedienungs- und Wartungsanleitung ist bei der Übergabe der Anlage dem Hauseigentümer abzugeben.

Einsatzbereich

Der Druckminderer **JRGURED** ist für folgende Einsatzbereiche zugelassen:

JRG Code	PN kPa/bar	p_{sek} kPa/bar	t_{max} °C
1300/1303	2'500/25	200–600/2–6	30
1310	2'500/25	200–600/2–6	70
1320	2'500/25	50–200/0.5–2	70
1330	2'500/25	600–1'000/6–10	70

Kennzeichnung

- 1/2–2 1/2 (GN/Ventilgrösse)
- **JRGURED** (Name der Armatur)
- JRG (Herstellerzeichen)
- Durchflusspfeile



AFM 34 Dichtungen dürfen nicht geölt oder gefettet werden.

Werkseinstellung

Die Druckminderer **JRGURED** werden werkseitig wie folgt eingestellt:

JRG Code 1300/1303	400 kPa / 4 bar
JRG Code 1310	400 kPa / 4 bar
JRG Code 1320	200 kPa / 2 bar
JRG Code 1330	600 kPa / 6 bar

Andere Einstelldrücke auf Anfrage.

Bedienungs- und Wartungsanleitung



Vor der Inbetriebnahme des Druckminderers ist die Zuleitung gründlich zu spülen.

Inbetriebnahme



Absperrventil vor dem Druckminderer langsam öffnen.

Der Druckminderer **JRGURED** ist betriebsbereit.

D

Schlüsselweite (SW) der Sechskant-Stiftschlüssel

Druckminderer		
GN	DN	SW
$\frac{1}{2} + \frac{3}{4}$	15 + 20	5 mm
$1 + 1\frac{1}{4}$	25 + 32	6 mm
$1\frac{1}{2}, 2 + 2\frac{1}{2}$	40, 50 + 65	8 mm

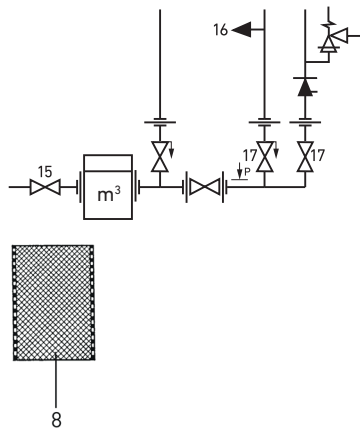
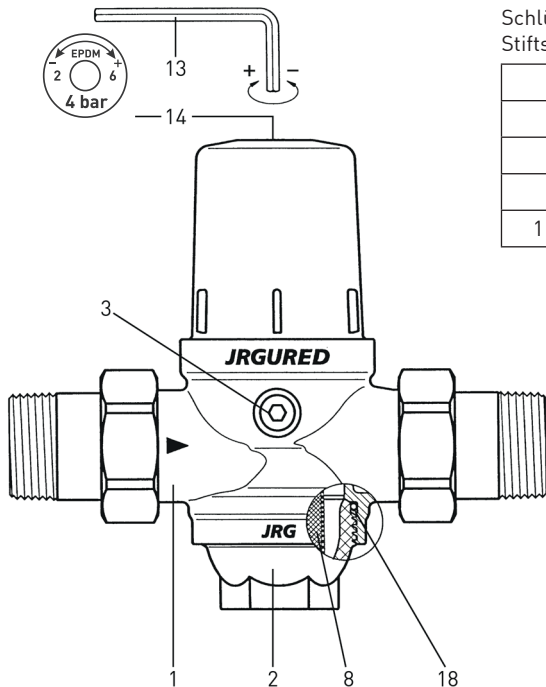

Umstellung des Druckminderers



Ein Umstellen der Werkseinstellung erfolgt ausschliesslich auf Verantwortung des Ausführenden.

Die Druckeinstellung des Druckminderers kann wie folgt umgestellt werden:

Druckminderer durch Öffnen (ca. 0,5 l/min) einer Entnahmestelle **16** entlasten. Den Sechskant-Stiftschlüssel **13** an der Einstellschraube **14** ansetzen. Durch Drehen des Schlüssels im Uhrzeigersinn wird der Sekundärdruck erhöht, durch Drehen im Gegen- uhrzeigersinn vermindert.

Eine Schlüsselumdrehung von 360° entspricht einer Druckänderung von:

Druckminderer GN ½	35 kPa / 0,35 bar
Druckminderer GN ¾–2 ½	30 kPa / 0,30 bar

Nach erfolgter Umstellung die geöffnete Entnahmestelle **16** schliessen.



Die Druckeinstellung muss nach erfolgter Änderung mit einem Manometer bei Ruhedruck (Nullverbrauch) kontrolliert werden.



Es ist darauf zu achten, dass die Druckeinstellung den örtlich geltenden Vorschriften entspricht.

Wartung



Am Druckminderer **JRGURED** dürfen **keine** Reparaturen vorgenommen werden.

Filterreinigung

Vor dem Absperrn der Ventile einen sauberen Eimer mit Wasser füllen.

- Absperrventile **15 + 17** vor und nach dem Druckminderer schliessen.
- Durch Lösen der Belüftungsschraube **3** den Druckminderer entspannen.
- Filterbecher **2** mit einem Schraubenschlüssel lösen und entfernen.
- Grobfilter **8** entfernen.
- Filterbecher und Grobfilter mit Wasser (ohne Zusätze) gründlich reinigen.
- Durch kurzes Öffnen des Absperrventils **15** den Druckminderer ausspülen.
- O-Ring-Dichtung **18** ohne zu beschädigen aus der O-Ringnut im Ventilgehäuse entfernen, reinigen und mit Silikonfett leicht einfetten.
- Innenpartien (Dichtungsbereich) am Gehäuse **1** des Druckminderers reinigen, evtl. Kalkansätze entfernen.



Schnittverletzungsgefahr durch scharfkantige Innenpartien.

→ Schutzhandschuhe tragen.

- O-Ring-Dichtung **18** vorsichtig in die O-Ringnut im Ventilgehäuse einsetzen.
- Grobfilter **8** in den Filterbecher einsetzen.
- Filterbecher **2** vorsichtig am Innengewinde des Druckminderers ansetzen und mit einem Schraubenschlüssel (im Gegenuhrzeigersinn) leicht handsatt anziehen.
- Belüftungsschraube **3** festziehen.
- Absperrventil **15** vor und folgend die Absperrventile **17** nach dem Druckminderer langsam öffnen.

Betriebsstörungen/Ersatzteile



Bei Betriebsstörungen sowie für Grobfilter-Ersatzteile wenden Sie sich bitte an Ihren Sanitär-Installateur.

JRG

+GF+

Notice d'utilisation et d'entretien

JRGURED

Réducteur de pression
Nettoyage du filtre

F

9-16
16

PN 25 GN 1/2-2 1/2

JRG Code 1300/1303, 1310, 1320, 1330

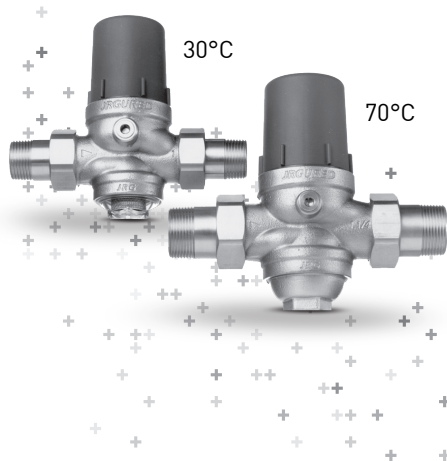

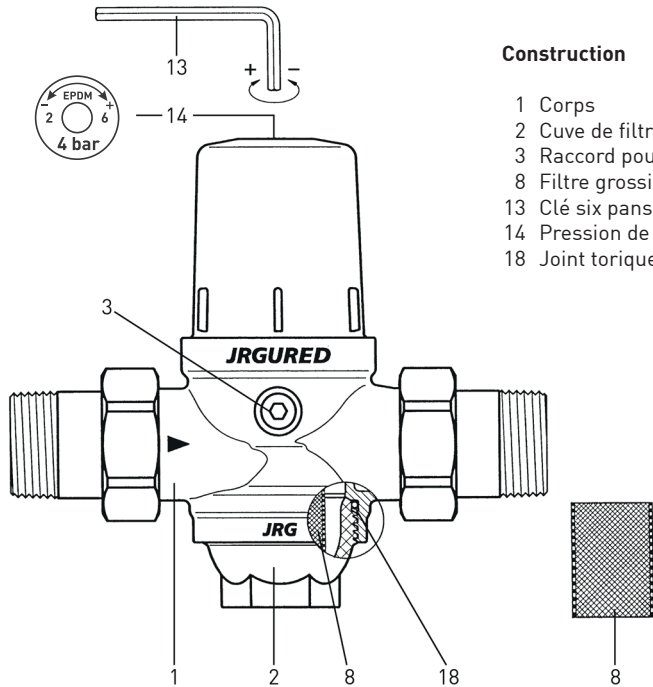

Construction

- 1 Corps
- 2 Cuve de filtre
- 3 Raccord pour manomètre/vis de purge
- 8 Filtre grossier
- 13 Clé six pans
- 14 Pression de réglage
- 18 Joint torique O-Ring

Notice d'utilisation et d'entretien

Lire attentivement la notice d'utilisation et d'entretien suivantes!

Les symboles utilisés signifient:



Danger

Ce symbole rend attentif les personnes sur le risque élevé de blessures. La notice de sécurité est à respecter.



Avertissement

Ce symbole rend attentif que si l'on observe pas la notice, il peut se produire des dommages importants. La notice de sécurité est à respecter.



Indication

Ce symbole rend attentif sur les instructions importantes d'usage. Le non-respect peut entraîner des dérangements ou des pannes.

Introduction

Le réducteur de pression **JRGURED** est un élément de robinetterie compact, destiné aux installations de distribution d'eau*, constitué d'un filtre grossier et d'un réducteur de pression.

* Autres applications sur demande.

Fonctionnement

Selon la nature de l'installation, la pression de l'eau du réseau de distribution doit être réduite à une valeur convenable.

Le réducteur de pression **JRGURED** réduit la pression d'entrée à une pression d'utilisation réduite constante.

Le filtre grossier, monté de série en amont du réducteur de pression, retient les particules en suspension dont la taille est supérieure à 1000 µm. Au besoin ou lors d'une chute de pression sensible pendant l'utilisation, le filtre grossier doit être nettoyé.



L'eau potable étant une denrée alimentaire, le filtre grossier ainsi que la cuve doivent être nettoyés uniquement à l'eau, sans aucun détergent. Suivre les indications de la notice d'entretien ci-jointe.

Recommandation

Des particules comme le calcaire, la rouille, le sable, etc. peuvent parvenir à l'installation du bâtiment via le réseau de distribution d'eau public à la suite de réparations, de rénovations et autres.

Pour protéger le réducteur de pression **JRGURED** ainsi que tout le réseau de distribution d'eau interne de ces impuretés, nous recommandons de monter en amont du réducteur de pression **JRGURED** un filtre fin JRG (1830-1846 ou 1870) avec un seuil de filtrage de 100 µm.

Remarques



Aucune réparation ne doit être tentée sur le réducteur de pression **JRGURED**.



D'éventuels réglages de pression doivent être exécutés que par un spécialiste du sanitaire, et ce conformément à la notice d'utilisation ci-jointe.



L'entretien du filtre se fera selon les indications de la notice correspondante.

La notice d'utilisation et d'entretien sera donnée au propriétaire lors de la remise de l'installation.

Domaine d'utilisation

Le réducteur de pression **JRGURED** est homologué pour les domaines d'utilisation suivants:

JRG Code	PN kPa/bar	p_{sec} kPa/bar	t_{max} °C
1300/1303	2'500/25	200-600/2-6	30
1310	2'500/25	200-600/2-6	70
1320	2'500/25	50-200/0.5-2	70
1330	2'500/25	600-1'000/6-10	70

Repérage

- 1/2-2 1/2 (GN/grandeur de vanne)
- **JRGURED** (nom de la robinetterie)
- JRG (logo du fabricant)
- Flèches de débit



Ne jamais graisser ni huiler les joints plats en fibrine AFM 34.

Réglage d'usine

Les réducteurs de pression **JRGURED** sont réglés en usine comme suit:

JRG Code 1300/1303	400 kPa / 4 bar
JRG Code 1310	400 kPa / 4 bar
JRG Code 1320	200 kPa / 2 bar
JRG Code 1330	600 kPa / 6 bar

Autres pressions de réglage sur demande.

Notice d'utilisation et d'entretien



Avant la mise en service du réducteur de pression, rincer soigneusement la conduite d'alimentation.

Mise en service



Ouvrir lentement le robinet d'arrêt placé en amont du réducteur de pression.

Le réducteur de pression **JRGURED** est ensuite prêt au fonctionnement.

F

Cote sur plat de clé six pans

Réducteurs de pression		
GN	DN	SW
1/2 + 3/4	15 + 20	5 mm
1 + 1 1/4	25 + 32	6 mm
1 1/2, 2 + 2 1/2	40, 50 + 65	8 mm

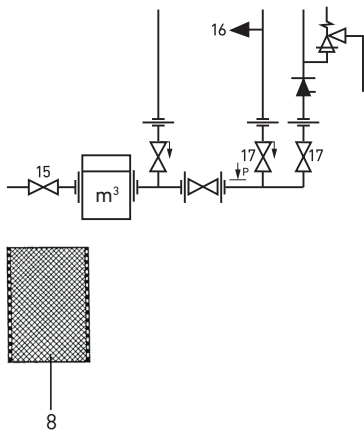
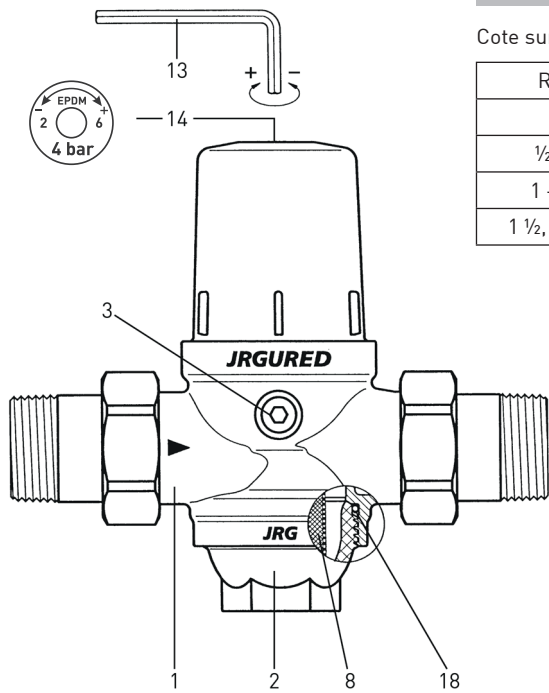

Modification de la valeur de consigne du réducteur de pression



Une modification de la valeur réglée en usine se fait sous l'entière responsabilité de l'exécutant.

La valeur de consigne du réducteur de pression peut être modifiée comme suit:

Délester le réducteur de pression en ouvrant (en. 0.5 l /min.) un consommateur **16**. Introduire la clé six pans **13** dans la vis de réglage de pression **14**. La pression secondaire est augmentée en tournant la clé dans le sens horaire, elle diminue en tournant dans le sens horaire inverse.

Un tour de clé de 360° correspond à une modification de la pression de:

Réducteur de pression GN ½	35 kPa / 0,35 bar
Réducteur de pression GN ¾-2 ½	30 kPa / 0,30 bar

Une fois la modification faite, refermer le consommateur **16**.



Après la modification, le réglage de pression doit être contrôlé avec un manomètre, cela pendant la pression de repos (sans consommation).



Veiller à ce que la pression ajustée corresponde aux prescriptions local.

Entretien



Aucune réparation ne doit être tentée sur le réducteur de pression **JRGURED**.

Nettoyage du filtre

Avant de fermer les vannes, remplir un seau propre avec de l'eau.

- Fermer les robinets d'arrêt **15 + 17** avant et après le réducteur de pression.
- Délester le réducteur de pression en dévissant la vis de purge **3**.
- Libérer et enlever la cuve de filtre **2** avec une clé de serrage.
- Enlever le filtre grossier **8**.
- Nettoyer soigneusement la cuve et le filtre grossier à l'eau (sans aucun additif).
- Rincer le réducteur de pression en ouvrant brièvement le robinet d'arrêt **15**.
- Enlever le joint torique **18** de la rainure du boîtier de vanne sans l'endommager, le nettoyer et le graisser légèrement au silicone.
- Nettoyer les parties intérieures (zone du joint) sur le corps **1** du réducteur de pression, ôter si nécessaire les dépôts de tartre.



Danger de coupure à cause des arêtes intérieures aiguës.

→ Porter des gants.

- Remettre soigneusement en place le joint torique **18** dans sa rainure.
- Glisser le filtre grossier **8** dans la cuve de filtre.
- Présenter avec précaution la cuve **2** sur le filetage intérieur du réducteur de pression et le serrer légèrement avec une clé de serrage (dans le sens horaire inverse).
- Serrer la vis de purge **3**.
- Ouvrir lentement le robinet d'arrêt **15** devant et le robinet d'arrêt **17** derrière le réducteur de pression.

Pannes/pièces de rechange



En cas de panne et pour remplacer les pièces de filtre grossier, vous voudrez bien vous adresser à votre installateur sanitaire.

JRG

+GF+

Istruzioni d'uso e manutenzione

JRGURED

Riduttore di pressione
Pulizia del filtro

I 17-24
24

PN 25 GN 1/2-2 1/2

JRG Code 1300/1303, 1310, 1320, 1330

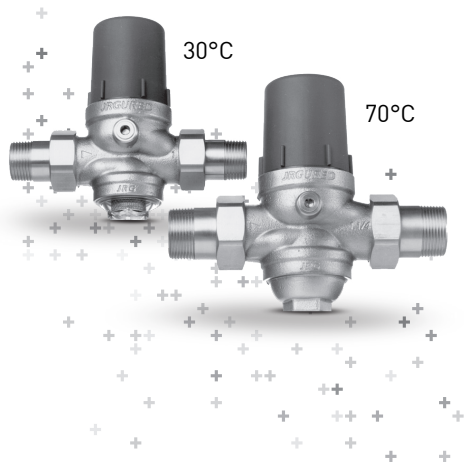

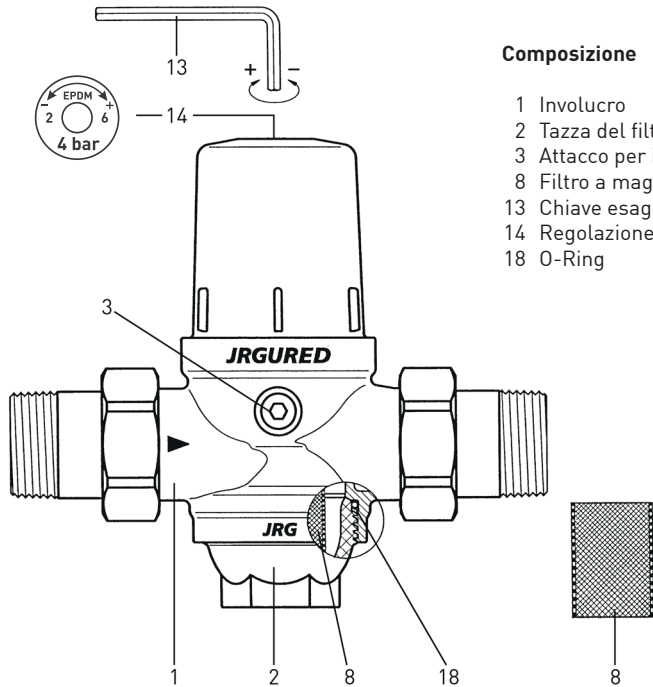

Composizione

- 1 Involucro
- 2 Tazza del filtro
- 3 Attacco per il manometro/vite di aerazione
- 8 Filtro a maglie larghe
- 13 Chiave esagonale
- 14 Regolazione della pressione
- 18 O-Ring

Istruzioni d'uso e di manutenzione

Vogliate avere la cortesia di leggere attentamente la presente istruzione di manutenzione. I simboli seguenti significano:



Pericolo

Questo simbolo sta ad indicare il rischio di danni a persone. Deve essere obbligatoriamente osservato.



Attenzione

Questo simbolo indica un'informazione che l'inosservanza della quale può portare a dei grossi danni. Queste indicazioni sulla sicurezza sono da osservare attentamente.



Avvertenza

Questo simbolo informa su importanti indicazioni concernenti l'utilizzo. L'inosservanza delle quali può causare dei guasti.

Generalità

Il riduttore di pressione **JRGURED** è una rubinetteria compatta per installazioni idrauliche*, composta da un filtro a maglie larghe e dal riduttore di pressione propriamente detto.

* Altre applicazioni su richiesta.

Funzionamento

Secondo l'impianto, è necessario ridurre a valori accettabili le pressioni dell'acqua della rete di approvvigionamento.

Il riduttore di pressione **JRGURED** riduce la pressione all'entrata a un livello inferiore e costante.

Il filtro a maglie larghe, installato di serie a monte del riduttore di pressione, trattiene le sostanze in sospensione, di dimensioni maggiori di 1000 μm . In caso di bisogno, oppure di notevole calo di pressione durante il prelievo d'acqua, è necessario procedere alla pulizia del filtro a maglie larghe.



Poiché l'acqua potabile è una sostanza alimentare, tanto il filtro a maglie larghe, quanto la relativa tazza devono essere lavati unicamente con la stessa acqua, senza aggiunta di detersivi. Per la pulizia, attenersi alle istruzioni per la manutenzione qui appresso.

Consiglio

Le sostanze in sospensione, come calcare, ruggine, sabbia, ecc. possono provenire dalla rete di approvvigionamento pubblica in seguito a riparazioni, risanamenti, ecc. e infiltrarsi nella rete di distribuzione domestica attraverso la condotta di raccordo.

Allo scopo di proteggere il riduttore di pressione **JRGURED** e l'intera rete di distribuzione domestica da queste impurità, consigliamo d'installare, a monte del riduttore di pressione, un filtro a maglie fini JRG (1830-1846 o 1870) con elemento filtrante fino a 100 µm.

Attenzione



Nessuna riparazione può essere effettuata sul riduttore di pressione **JRGURED**.



Eventuali modifiche della regolazione devono essere eseguite esclusivamente da uno specialista sanitario, conformemente alle istruzioni per l'uso qui appresso.



Per la manutenzione del filtro a maglie larghe, attenersi alle istruzioni per la manutenzione.

Le istruzioni per l'uso e la manutenzione devono essere date al proprietario della casa al momento della consegna dell'impianto.

Campo d'impiego

Il riduttore di pressione **JRGURED** è approvata per i seguenti campi d'impiego:

JRG Code	PN kPa/bar	p_{sec} kPa/bar	t_{max} °C
1300/1303	2'500/25	200-600/2-6	30
1310	2'500/25	200-600/2-6	70
1320	2'500/25	50-200/0.5-2	70
1330	2'500/25	600-1'000/6-10	70

Contrassegno

- 1/2-2 1/2 (GN/misura del riduttore)
- **JRGURED** (nome della rubinetteria)
- JRG (marchio di fabbrica)
- frecce d'indicazione del flusso



Le guarnizioni AFM 34 non devono essere oleate né ingrassate.

Regolazione di fabbrica

I riduttori di pressione **JRGURED** sono regolati di fabbrica nel modo seguente:

JRG Code 1300/1303	400 kPa / 4 bar
JRG Code 1310	400 kPa / 4 bar
JRG Code 1320	200 kPa / 2 bar
JRG Code 1330	600 kPa / 6 bar

Altre pressioni di regolazione su richiesta.

Istruzioni per l'uso e la manutenzione



Prima della messa in esercizio dei riduttori di pressione, occorre risciacquare a fondo la condotta d'alimentazione.

Messa in esercizio



Aprire lentamente la valvola d'arresto a monte del riduttore di pressione.

Il riduttore di pressione **JRGURED** è pronto all'impiego.

I

Dimensione della chiave di regolaggio esagonale

Riduttore di pressione		⬡
GN	DN	DC
1/2 + 3/4	15 + 20	5 mm
1 + 1 1/4	25 + 32	6 mm
1 1/2, 2 + 2 1/2	40, 50 + 65	8 mm

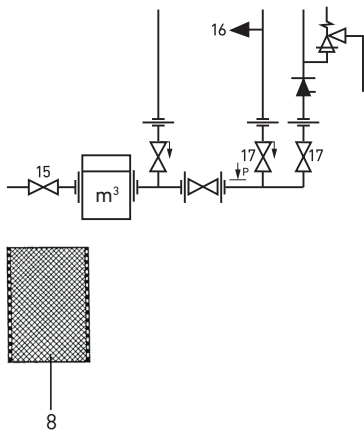
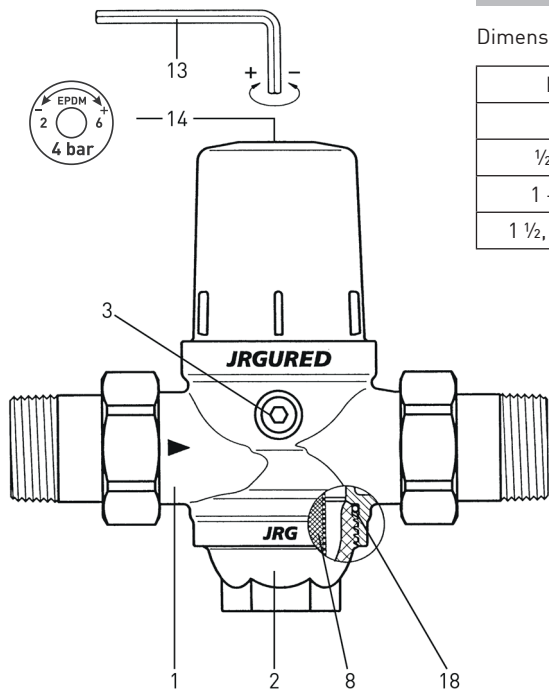

Modifica delle regolazioni



La modifica delle regolazioni avviene sotto la responsabilità esclusiva di chi la effettua.

La regolazione della pressione del riduttore di pressione può essere modificata procedendo come segue:

Scaricare il riduttore di pressione (ca. 0.5 l/min.) aprendo un punto acqua **16**. Inserire la chiave esagonale **13** nella vite di regolaggio della pressione **14**. Girando la chiave in senso orario si aumenta la pressione secondaria, in senso antiorario si diminuisce.

Un giro di chiave di 360° corrisponde a una variazione di pressione di:

Riduttore di pressione GN ½	35 kPa / 0,35 bar
Riduttore di pressione GN ¾-2 ½	30 kPa / 0,30 bar

Una volta effettuata la regolazione, chiudere di nuovo il punto di prelievo **16**.



La regolazione della pressione, una volta effettuata, deve essere controllata con il manometro, a pressione di riposo (erogazione zero).



Badare che la regolazione della pressione sia conforme alle prescrizioni locali.

Manutenzione



Nessuna riparazione può essere effettuata al riduttore di pressione **JRGURED**.

Pulizia del filtro

Prima di chiudere i rubinetti riempire di acqua un secchio pulito.

- Chiudere i rubinetti d'arresto **15 + 17** a monte e a valle del riduttore di pressione.
- Allentando la vite di sfiato **3**, scaricare la pressione del riduttore di pressione.
- Con l'apposita chiave, allentare e togliere la tazza del filtro **2**.
- Togliere l'elemento filtrante a maglie larghe **8**.
- Pulire accuratamente con acqua (senza additivi) la tazza del filtro e l'elemento filtrante a maglie larghe.
- Aprendo brevemente il rubinetto d'arresto **15**, risciacquare il riduttore di pressione.
- Togliere senza danneggiarla la guarnizione O-ring **18** dalla sua scanalatura nel corpo del riduttore, ripulirla e lubrificarla leggermente con grasso al silicone.
- Pulire le parti interne (zona di tenuta ermetica) del corpo **1** del riduttore di pressione, se occorre eliminarne i residui calcarei.



Pericolo di tagliarsi, per via dei bordi affilati delle parti interne.
→ Mettere i guanti di protezione.

- Posizionare con prudenza la guarnizione O-ring **18** nella sua scanalatura del corpo del riduttore.
- Inserire l'elemento filtrante a maglie larghe **8** nella tazza del filtro.
- Accostare con prudenza la tazza del filtro **2** alla filettatura interna del riduttore di pressione e serrare leggermente con forza manuale per mezzo di una chiave (in senso antiorario).
- Serrare la vite di sfiato **3**.
- Aprire lentamente il rubinetto d'arresto **15** a monte e quelli **17** a valle del riduttore di pressione.

Guasti di funzionamento/ricambi



In caso di guasto e per i ricambi del filtro a maglie larghe, vogliate rivolgervi al vostro installatore sanitario.

JRG

+GF+

Operating and maintenance instructions

JRGURED

Pressure-reducing valve
To clean the filter

E 25-32
32

PN 25 GN 1/2-2 1/2

JRG Code 1300/1303, 1310, 1320, 1330

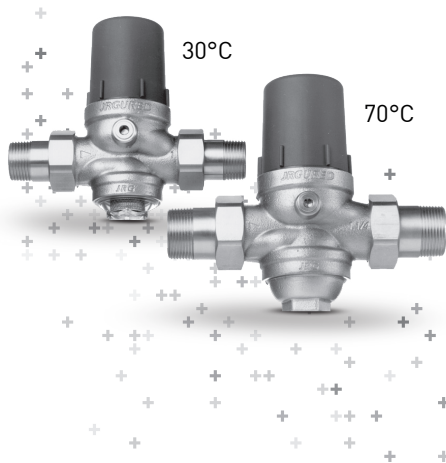

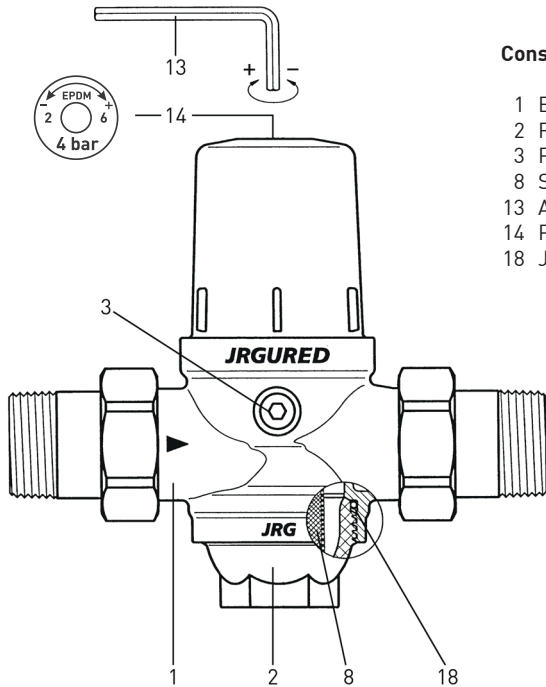

Construction

- 1 Bronze body
- 2 Filter cup
- 3 Pressure gauge connection/vent screw
- 8 Strainer
- 13 Allen key
- 14 Pressure setting
- 18 Joint O-Ring

Operating and maintenance instructions

Please read carefully the operating and maintenance instructions.

The used symbols mean:



Danger

This symbol indicate a high risk of injure for persons. It must be strictly observed.



Warning

This symbol point out an information, ignoring of it can cause extensive material damage. The security information has to be observed.



Note

This symbol point out an information, which indicate important details concerning the use of the valve. Ignoring of it can result in trouble.

Introduction

The pressure-reducing valve **JRGURED** is a compact fitting for water systems*, consisting of a coarse filter and a pressure-reducing valve.

* Other applications on request.

Function

The pressure of water from the main supply network may have to be reduced to a value suitable for the consumer's system.

The pressure-reducing valve **JRGURED** decreases the inlet pressure to a lower, constant outlet pressure.

The coarse filter incorporated as a standard feature retains suspended particles, which are larger than 1'000 µm. When required or in case of a noticeable pressure drop during the consumption of water, the coarse filter has to be cleaned.

E



Since drinking water is a foodstuff, the coarse filter as well as the filter cup must only be cleaned with potable water, without any added cleaning agents. In doing so, the following maintenance instructions have to be observed.

Recommendation

Suspended particles such as lime, rust, sand, etc., can get into the domestic water supply system via the building connection line as a result of repair and rehabilitation work on the public water mains system.

In order to protect the pressure-reducing valve **JRGURED** as well as the complete domestic water supply system from such contaminants, we recommend the installation of a JRG fine filter (1830–1846 or 1870) with a filtering capacity of 100 micron ahead of the pressure-reducing valve.

Notes



Repairs to the pressure-reducing valve **JRGURED** must not be attempted.



Any changes to the pressure setting have to be carried out exclusively by a qualified sanitary fitter in accordance with the following operating instructions.



The maintenance instructions have to be complied with for the maintaining of the coarse filter.

The operating - and the maintenance instructions have to be given to the building owner when the installation is handed over.

Operating range

The pressure-reducing valve **JRGURED** is approved for the following operating ranges:

JRG Code	PN kPa/bar	p_{sec} kPa/bar	t_{max} deg C
1300/1303	2'500/25	200–600/2–6	30
1310	2'500/25	200–600/2–6	70
1320	2'500/25	50–200/0.5–2	70
1330	2'500/25	600–1'000/6–10	70

Identification

- ½–2 ½ [GN/valve size]
- **JRGURED** (name of the fitting)
- JRG (manufacturer's trademark)
- Flow direction arrows



Seals made of AFM 34 should never be used with grease or oil.
(AFM = Asbestos Free Material)

Factory setting

The pressure-reducing valve **JRGURED** are set at the factory to the following secondary pressures:

JRG Code 1300/1303	400 kPa / 4 bar
JRG Code 1310	400 kPa / 4 bar
JRG Code 1320	200 kPa / 2 bar
JRG Code 1330	600 kPa / 6 bar

Other pressure settings on request.

Operating and maintenance instructions



Before commissioning the pressure-reducing valve, the inlet line has to be thoroughly flushed out.

Commissioning:



Slowly open the shut-off valve upstream of the pressure-reducing valve. The pressure-reducing valve **JRGURED** is ready for operation.

E

Allen key size (KS) of hexagon pin key

Pressure-reducing valve		⬡
INCH	DN	KS
1/2 + 3/4	15 + 20	5 mm
1 + 1 1/4	25 + 32	6 mm
1 1/2, 2 + 2 1/2	40, 50 + 65	8 mm

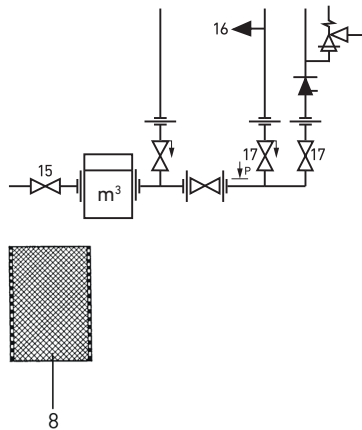
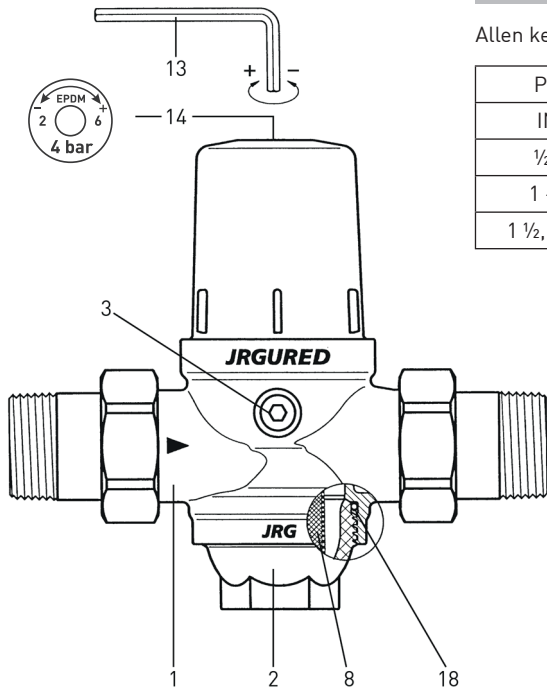

Resetting the pressure-reducing valve



Any change to the factory pressure setting is carried out exclusively on the responsibility of the person doing so.

The pressure setting of the pressure-reducing valve can be changed as follows:

Relieve (approx. 0.5 l/min.) the pressure reducing valve by opening a tap **16**. Set the Allen key **13** at the pressure adjustment **14**.

Turning the key clockwise, the secondary pressure increases, turning it counterclockwise it decreases.

One full rotation of the key through 360 deg. corresponds to a pressure change of:

Pressure-reducing valve GN ½	35 kPa / 0,35 bar
Pressure-reducing valve GN ¾–2 ½	30 kPa / 0,30 bar

Close outlet **16** after pressure change.



The pressure setting has to be checked with a pressure gauge at steady-state pressure (no water consumption).



Attention must be paid, that the pressure setting corresponds to the local regulations.

Maintenance



Repairs to the pressure-reducing valve **JRGURED** must not be attempted.

Cleaning the filter

Before closing the valves, fill a clean bucket with water.

- Close the shut-off valves **15 + 17** upstream and downstream of the pressure-reducing valve.
- Relieve the pressure-reducing valve of pressure by loosening the venting screw **3**.
- Release the filter cup **2** by turning it with a wrench and remove it.
- Remove the filter tube **8**.
- Thoroughly clean the filter cup and filter tube with water (without any cleaning agents).
- By briefly opening the shut-off valve **15**, flush out the pressure-reducing valve.
- Remove the O-ring seal **18** from the O-ring groove in the valve housing without damaging it, clean it and lightly grease it with silicone grease.
- Clean the inside parts (sealing zone) of the housing **1** of the pressure-reducing valve, remove any lime scale deposits.



Attention! Danger of cuts due to sharp-edged inside parts.

→ Wear protective gloves.

- Carefully replace the O-ring seal **18** in the O-ring groove in the valve housing.
- Insert the filter tube **8** into the filter cup.
- Carefully position the filter cup **2** on the internal thread of the pressure-reducing valve and tighten it gently with a wrench until it is hand-tight.
- Tighten venting screw **3**.
- Slowly open the shutoff valve **15** upstream and following it the shutoff valves **17** downstream of the pressure-reducing valve.

Operational problems/spare parts



In the case of operational problems as well as for spare parts for the coarse filter, please contact your plumber.

JRG

+GF+

Instrucciones de mantenimiento y funcionamiento

JRGURED

Válvula reductora de presión ES 33-40
Limpieza del filtro 40

PN 25 GN 1/2-2 1/2

JRG Code 1300/1303, 1310, 1320, 1330

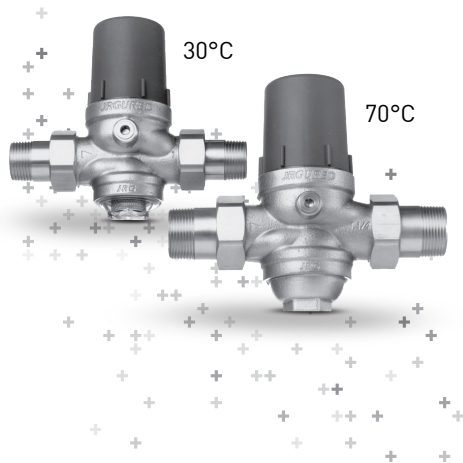

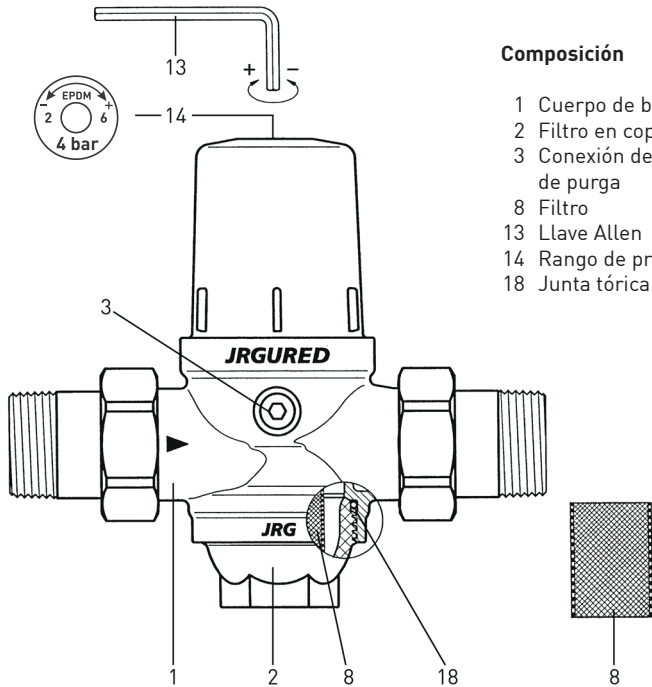

Composición

- 1 Cuerpo de bronce
- 2 Filtro en copa
- 3 Conexión de manómetro/Tornillo de purga
- 8 Filtro
- 13 Llave Allen
- 14 Rango de presión/ajustes
- 18 Junta tórica

Instrucciones de mantenimiento y funcionamiento

Lea detenidamente las instrucciones de mantenimiento y funcionamiento.

Significado de los símbolos utilizados:



Peligro

Este símbolo indica alto riesgo de lesiones en personas. Se debe cumplir de forma estricta.



Advertencia

Este símbolo indica información, ignorarlo puede dañar gravemente el material.

Se debe cumplir la información de seguridad.



Nota

Este símbolo indica información con datos importantes relacionados con el uso de la válvula. Ignorarlo puede derivar en un problema.

Introducción

La válvula reductora de presión **JRGURED** es un componente compacto para sistemas de agua*, que consiste en un filtro de malla y en una válvula reductora de presión.

* Otras aplicaciones bajo petición.

Función

Reducir la presión del agua de la red de abastecimiento principal a un valor adecuado para el consumo.

La válvula reductora de presión **JRGURED** disminuye la presión de entrada a una presión inferior y constante.

El filtro grueso incorporado de serie retiene las partículas en suspensión que superen los 1000 μ m. El filtro grueso debe limpiarse bien cuando sea necesario o en caso de una drástica bajada de presión durante el consumo de agua.



Dado que el agua potable es un producto alimenticio, el filtro grueso y el filtro en copa solo deben limpiarse con agua potable, sin añadir productos de limpieza. Para hacerlo, debe seguir las siguientes instrucciones de mantenimiento.

Recomendación

Las partículas en suspensión como la cal, el óxido, la arena, etc. pueden introducirse en el sistema de abastecimiento de agua doméstica a través de la tubería de conexión del edificio, como resultado de una reparación o rehabilitación del sistema principal de abastecimiento público.

A fin de proteger la válvula reductora de presión **JRGURED**, y el sistema completo de abastecimiento de agua doméstica, contra dichos contaminantes, recomendamos la instalación de un filtro fino JRG (JRG Code 1830-1846 o 1870), con una capacidad de filtrado de 100 micras por encima de la válvula reductora de presión.

Notas



No intente reparar la válvula reductora de presión **JRGURED**.



Cualquier modificación en los ajustes de presión debe realizarse exclusivamente por un instalador sanitario cualificado, según las siguientes instrucciones de funcionamiento.



Debe cumplir las instrucciones de mantenimiento para la conservación del filtro grueso.

Se deben entregar las instrucciones de mantenimiento y funcionamiento al dueño del edificio cuando se vaya a llevar a cabo la instalación.

Rango de funcionamiento

La válvula reductora de presión **JRGURED** es compatible con los siguientes rangos de funcionamiento:

JRG Code	PN kPa/bar	p_{sec} kPa/bar	t_{max} °C
1300/1303	2'500/25	200-600/2-6	30
1310	2'500/25	200-600/2-6	70
1320	2'500/25	50-200/0.5-2	70
1330	2'500/25	600-1'000/6-10	70

Identificación

- 1/2-2 1/2 (GN/tamaño de válvula)
- **JRGURED** (nombre de la válvula)
- JRG (marca comercial del fabricante)
- Flechas de sentido de flujo



Las juntas de AFM 34 no pueden ser aceitadas o engrasadas.

Ajustes de fábrica

La válvula reductora de presión **JRGURED** tiene fijada de fábrica las siguientes presiones secundarias:

JRG Code 1300/1303	400 kPa / 4 bar
JRG Code 1310	400 kPa / 4 bar
JRG Code 1320	200 kPa / 2 bar
JRG Code 1330	600 kPa / 6 bar

Otros ajustes de presión bajo petición.

Instrucciones de mantenimiento y funcionamiento



Antes de poner en marcha la válvula reductora de presión, la tubería de entrada tiene que estar completamente purgada.

Puesta en marcha



Abra despacio la llave de paso aguas arriba de la válvula reductora de presión.

La válvula reductora de presión **JRGURED** está lista para su funcionamiento.

Tamaño llave (KS) para ajustes

Válvula reductora de presión		KS
PULGADAS	DN	KS
1/2 + 3/4	15 + 20	5 mm
1 + 1 1/4	25 + 32	6 mm
1 1/2, 2 + 2 1/2	40, 50 + 65	8 mm

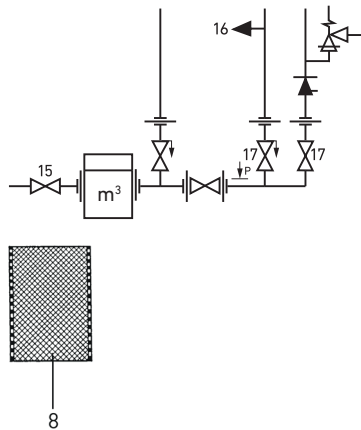
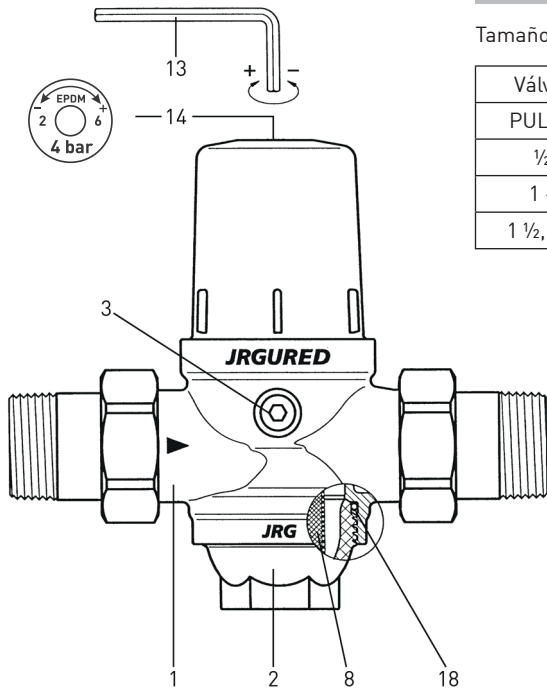

Reajustar la válvula reductora de presión



La responsabilidad de llevar a cabo cualquier modificación en los ajustes de presión de fábrica recaerá exclusivamente en la persona que los realice.

Los ajustes de presión de la válvula reductora pueden modificarse como se indica a continuación:

Disminuya la presión de la válvula reductora abriendo la salida **16** (aprox. 0,5 l/min). Insertar la llave Allen **13** en el tornillo **14**. Al girar la llave hacia la derecha, se aumenta la presión secundaria, al girarla hacia la izquierda la presión se reduce.

Un giro completo de 360° de la llave Allen corresponde a un cambio de presión de:

Válvula reductora de presión GN ½	35 kPa / 0,35 bar
Válvula reductora de presión GN ¾-2 ½	30 kPa / 0,30 bar

Cerrar la salida **16** después de cambiar la presión.



Los ajustes de presión deben comprobarse con un manómetro a una presión estable (sin consumo de agua).



Preste atención a que el ajuste de presión se corresponde con la normativa del servicio de agua local.

Mantenimiento



No intente reparar la válvula reductora de presión **JRGURED**.

Limpieza del filtro

Antes de cerrar las válvulas, llene un cubo limpio con agua:

- Cierre las llaves de paso **15 + 17** aguas arriba y aguas abajo de la válvula reductora de presión.
- Disminuya la presión de la válvula reductora aflojando el tornillo de purga **3**.
- Retire el filtro de copa **2** con una llave (girando hacia la derecha) y sáquelo.
- Retire la malla de filtrado **8**.
- Limpie en profundidad el filtro de copa y el tubo de filtrado con agua (sin productos de limpieza).
- Abriendo ligeramente la llave de paso **15**, purgue la válvula reductora de presión.
- Retire, sin dañarla, la junta tórica **18** de su ranura, alojada en la carcasa de la válvula, límpiela y engrásela ligeramente con lubricante de silicona.
- Limpie las partes internas (zona de juntas) de la carcasa **1** de la válvula reductora de presión, retire cualquier depósito de cal.



Atención Peligro de cortes por partes internas afiladas.

Use guantes protectores.

- Reemplace con cuidado la junta tórica **18** en su ranura, alojada en la carcasa de la válvula.
- Inserte la malla de filtrado **8** en el filtro de copa.
- Coloque con cuidado el filtro de copa **2** en la rosca interior de la válvula reductora de presión y apriete fuerte con una llave cuando ya no pueda apretarla a mano.
- Apriete el tornillo de purga **3**.
- Abra despacio la llave de paso **15** aguas arriba, seguida de las llaves **17** aguas abajo de la válvula reductora de presión.

Problemas de funcionamiento/Repuestos



En caso de tener problemas de funcionamiento o de necesitar repuestos para el filtro grueso, póngase en contacto con su proveedor.







JRG

+GF+

Georg Fischer JRG AG

Hauptstrasse 130, CH-4450 Sissach

Phone +41 (0)61 975 22 22, Fax +41 (0)61 975 22 00

info.jrg.ps@georgfischer.com

www.gfps.com

Einbaudatum: Date de montage: Data d'installazione: Built-in date:

Ihr Installateur: Votre installateur: Il vostro installatore: Your plumber:

