

Diaphragm Gauge Guard type Z500/Z501

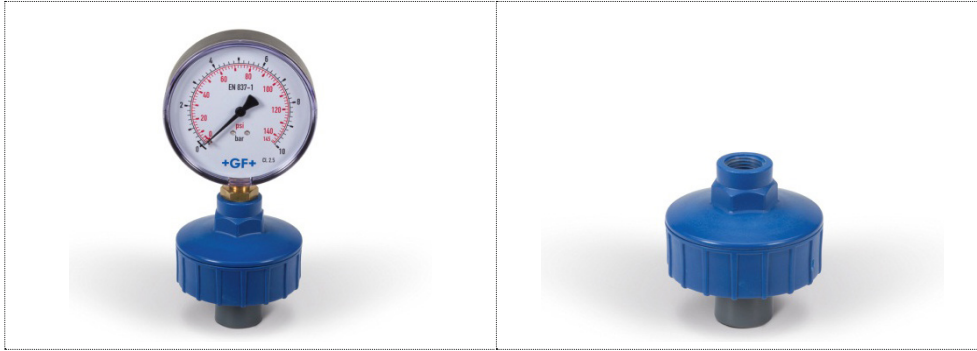

Type Z500
With manometer

Type Z501
Without manometer

Product description

The diaphragm-protected gauge guard Z500/Z501 is used when measuring the pressure of neutral and corrosive media.

Function

The manometer is separated from the medium by a TFM-coated EPDM-support diaphragm. The line pressure is transferred to the manometer via a buffer fluid.

The large area of the diaphragm and the low compressibility of the buffer fluid ensure an accurate display. The large number of possible materials makes for a wide range of areas of application.

Applications

- Chemical Process Industry
- Food and beverages
- Water treatment
- Cooling
- Ship building

Benefits/features

- All parts which come into contact with the medium are made of highly resistant plastics
- The manometer does not come into contact with the medium
- The gauge guard is low-maintenance and can be installed in any position
- Large diaphragm surface ensures high accuracy
- The new construction of the diaphragm gauge guard makes turning the diaphragms impossible, which guarantees an extremely precise transfer of pressure
- The new design guarantees an even sealing force on the diaphragms
- Various pipe connections are possible by exchanging the lower part

Technical data

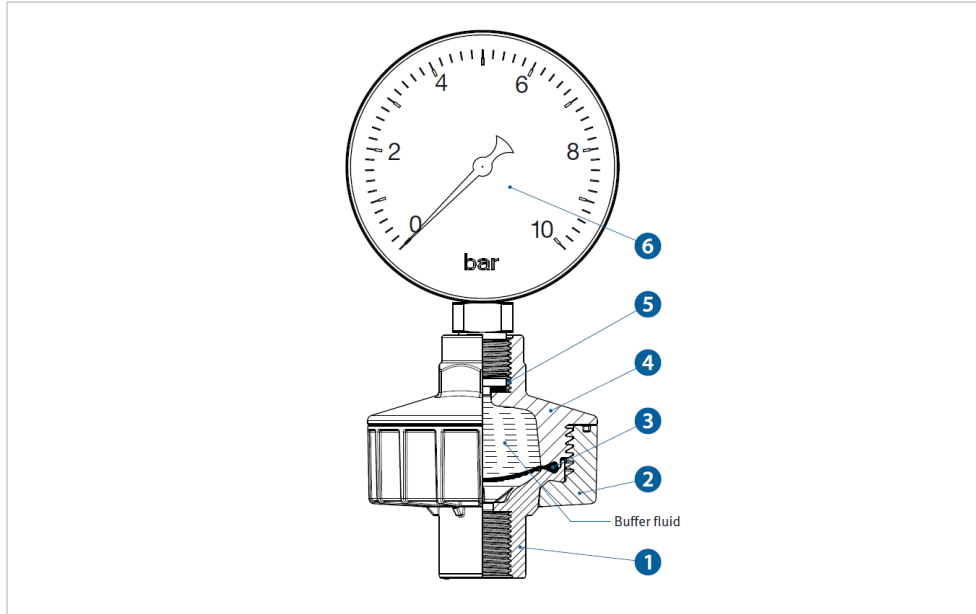

- 1 Lower part (PP, PVC and PVDF)
- 2 Coupling nut
- 3 Diaphragms EPDM/TFM
- 4 Upper part (PP GF)
- 5 Manometer gasket
- 6 Manometer

Specification

Dimensions	d25/DN20 – d32/DN25, ¾" – 1"
Lower part materials	PVC-U, PP-H, PVDF
Upper part material	PP-GF30
Gasket materials	PTFE
Buffer fluid	Glysantin (DI water upon request)
Pressure level	PN10 (10 bar@ 20°C 150 psi@ 68°F)
Manometer ranges	0 – 10 bar with R ¼" and with R ½" 0 – 6 bar with R ¼" and with R ½"
Manometer connections	G ¼" for d25 with 63 mm diameter G ½" for d32 with 100 mm diameter
Connection spigots	d25 with manometer adaptor socket R ¼" with inner thread G ¼" d32 with manometer adaptor socket R ½" with inner thread G ½" Other connections on request

Pressure-temperature diagrams

PVC-U, PP-H, PVDF

The pressure-temperature diagrams are based on a lifetime of 25 years and water or similar media.

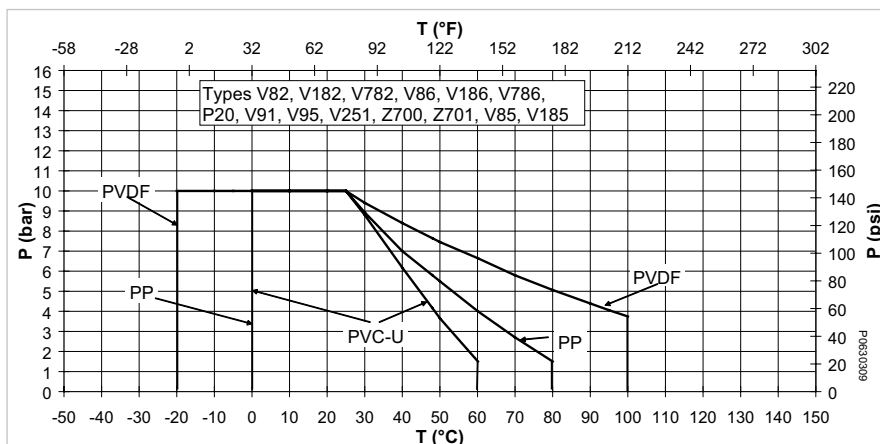

- T Temperature (°C, °F)
P Permissible pressure (bar, psi)

Technical basics

Handling

Filling with buffer fluid

- Fill the upper part of the diaphragm gauge guard Z500/Z501 up to the lower edge of the thread, preferably with Glysantin or distilled water
- Slightly move the diaphragm from below using a blunt object until no more air bubbles appear.
- Screw in the manometer.
- If the manometer then already displays a low pressure, some buffer fluid must be removed until no pressure display can be seen.

Installation notes

- Install the diaphragm gauge guard vertically with upstream threaded connection and shut-off valve. This guarantees that the manometer can also be moved into the desired reading position at a later stage and be exchanged without any problems (without turning off the system pressure).
- The diaphragm gauge guard may only be tightened using the hexagon on the housing or on the lower pipe socket using a strap wrench.
- In general, all commercially available manometers can be installed.

Maintenance notes

The diaphragm gauge guards are largely maintenance-free. It may be necessary to check whether a sufficient amount of buffer fluid is present.



Installation and maintenance must be performed in accordance with the corresponding installation manual. The installation manual is provided with the product, see also the online product catalogue at www.gfps.com.

Tips for installation

Distilled water in particular evaporates very easily at higher temperature, and therefore the buffer fluid may evaporate after years in service. If this happens, top up the buffer fluid.

Dimensions

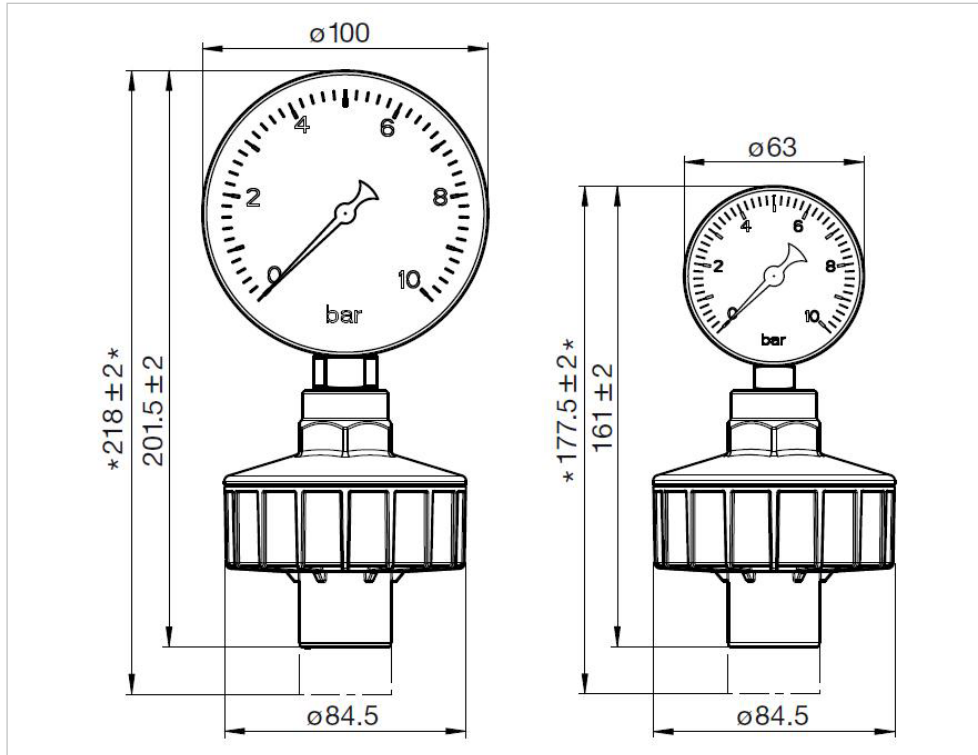

The information and technical data (altogether "Data") herein are not binding, unless explicitly confirmed in writing. The Data neither constitutes any expressed, implied or warranted characteristics, nor guaranteed properties or a guaranteed durability. All Data is subject to modification. The General Terms and Conditions of Sale of Georg Fischer Piping Systems apply.

12/2024-A

© Georg Fischer Piping Systems Ltd, 8201 Schaffhausen/Switzerland

Tel. +41 52 631 11 11 • www.gfps.com • E-Mail: info.ps@georgfischer.com