

NeoFlow Pressure Reducing Valve

DN50-DN300 / 2"-12"

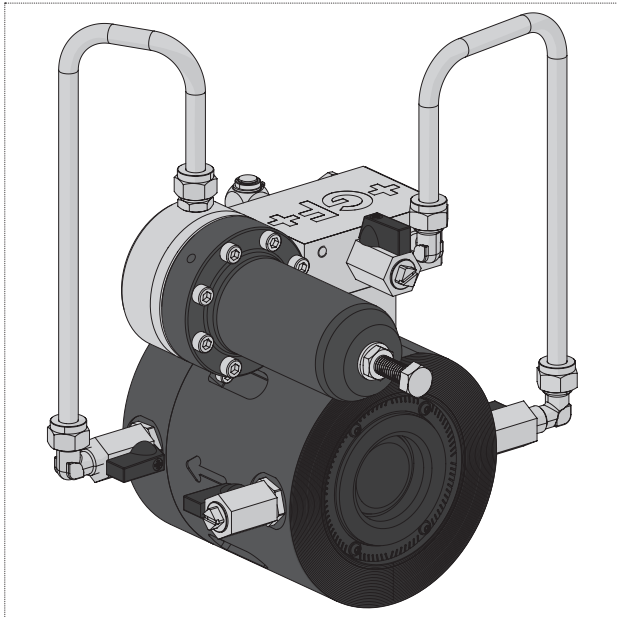

NeoFlow
Pressure Reducing Valve

Product description

The pilot-operated NeoFlow pressure reducing valve from GF Piping Systems was conceived for the automatic pressure and flow control in networks for the supply and distribution of water.

The NeoFlow pressure reducing valve is designed to fit between standard PN10 / PN16 in a wafer-type arrangement. ANSI 150 flange compatibility is also available.

No actuator stem or diaphragm: Significantly reduced complexity. Low maintenance requirements due to very simple design with few components and no elastomer diaphragm.

Axial flow: More accurate and very stable flow (down to zero), even at a small operating differential. Higher flow precision, also enabling pressure management in low pressure systems.

Smart valve: Integrated pilot valve to optimize pressure regulation and optional integrated equipment to monitor flow, and water quality.

9x lighter than a standard metal PRV.

5x more compact than a standard metal PRV.

40% less time to install than a standard metal PRV.

Applications

- Drinking water

Technical basics

Mode of operation

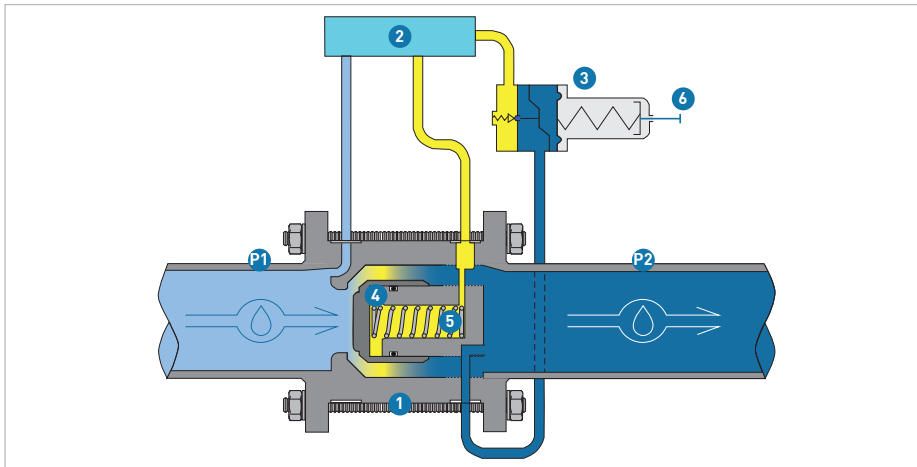

- 1 Main Body
- 2 Control block
- 3 Pilot valve
- 4 Piston valve
- 5 Control space
- 6 Adjusting screw
- P1 Inlet pressure
- P2 Adjustable outlet pressure

The axial movement of the piston valve (4) in the main body (1) results in flow changes in the NeoFlow pressure reducing valve and thus regulates the existing outlet pressure (P2). The position of the piston valve (4) is regulated by the prevalent pressure of the control area (5). Turning the adjusting bolt (6) on the pilot valve (3) sets the desired outlet pressure (P2). Depending on the existing outlet pressure (P2), the media flow in the pilot valve is changed (3). A change of the medium flow results in the adjustment of the pressure in the control area (5) via the control block (2). To equalize the pressure, the piston valve (4) moves axially in the main body (1).

Block wiring diagram

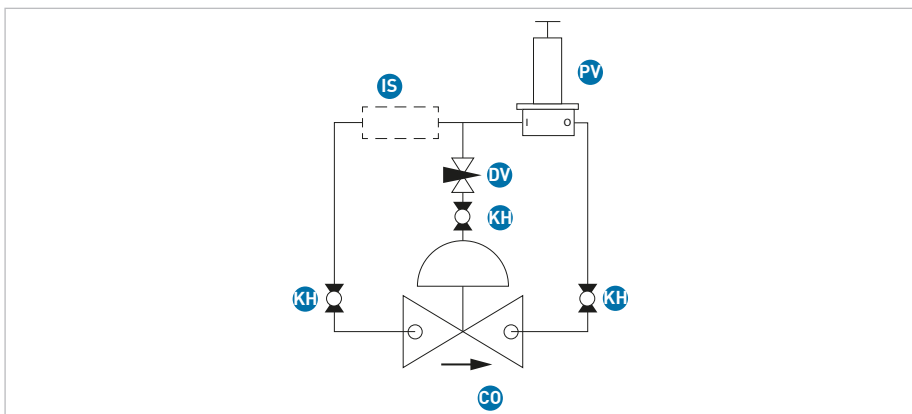

- PV Pilot valve
- IS Control block with integrated strainer
- KH Ball valve
- DV Damping valve
- CO Controller

Arrangement of the fittings

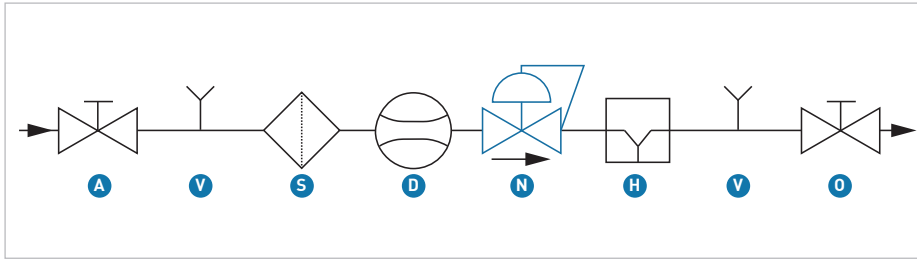

- A Shut-off valve inlet
- S Strainer
- D Flow measurement device
- N NeoFlow pressure reducing valve
- H Hydrant/splitter (recommended)
- O Shut-off valve, outlet
- V Air valve (recommended)

i In order to prevent and, if necessary, remove air from the system, it is recommended that two air relief valves are installed in the system. The best position is between the inlet valve and the strainer and between the hydrant/branch and the outlet valve or at the highest point of the installation line.

i Installation and maintenance must be carried out in accordance with the corresponding installation instructions. To be found under www.gfps.com/neoflow-manual or under www.gfps.com

Reference values for screw fastening

DN50 – DN300 in ISO-flange connections DIN 2501 / EN 1092 - PN16

DN (mm)	Do2 (mm)	Inch (")	Holes	Bolt metric	Minimum Bolt length (mm)*		Tightening torque** (Nm)
					Metal Flange to Metal Flange	Plastic Flange to Plastic Flange	
50	63	2	4	M16	200	230	25
80	90	3	8	M16	230	260	25
100	110	4	8	M16	250	290	30
150	160	6	8	M20	365	415	40
200	225	8	12	M20	420	490	50
250	280	10	12	M24	480	535	80
300	315	12	12	M24	540	595	80

*The screw length is dependently from the used material, please contact your GFPS expert for detailed information concerning your application. It is recommended to use stainless steel bolts, washers, and nuts.

**This torque information is just a reference, the tightening force depends on the materials and specific installation components that are used.

i Components and tightening torques can be determined using the online tool "Perfect Flange Connection Tool" under the following link: <https://www.gfps.com/perfectflangeconnection>

Technical data

Specifications

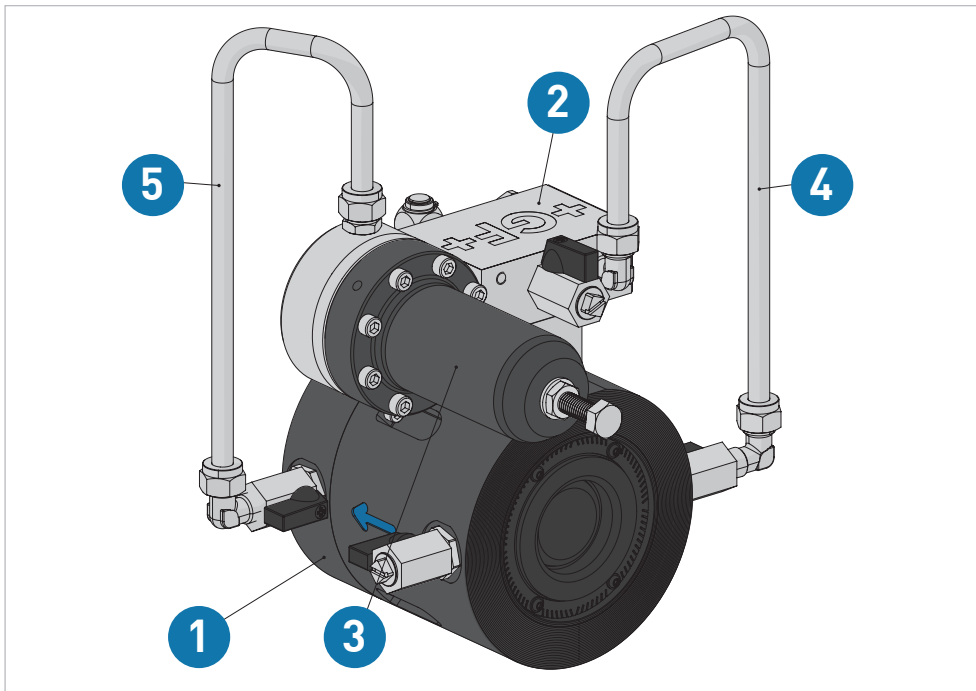

- 1 Main Body
- 2 Control block
- 3 Pilot valve
- 4 Inlet control line
- 5 Outlet control line

Specifications	
Dimensions	d63/DN50 – d315/DN300, 2" – 12"
Materials	Housing POM-C
	Piston POM-C
	Elastomers EPDM
	Fittings Stainless steel
	Pilot control Stainless steel, POM-C, EPDM
Pressure ratings	Maximum inlet pressure P1 16 bar / 232.1 psi*
	Maximum outlet pressure P2 16 bar / 232.1 psi**
	Outlet pressure range 0,1 to 16 bar / 1.5 to 232.1 psi**
	Minimal pressure difference P1– P2 0,2 bar / 2.9 psi***
Flanges	Metric: PN10/16
	Imperial: ANSI 150
Valve actuation	Pilot actuated; mechanical pilot valve
Classification acc. to ISO 1043	POM
Standards	EN1074-1
	EN1074-5

*With medium temperature ≤ 20°C; >20°C on request

**Depending on the pilot valve type

***Depending on flow and size

Flow characteristics

Kv 100-values

DN (mm)	Do2 (mm)	Inch (")	Kv 100 (l/min)	Kv 100 (m ³ /h)	Cv 100 (US gal./min)
50	63	2	633	38	44
80	90	3	1333	80	93
100	110	4	2383	143	165
150	160	6	5317	319	369
200	225	8	9417	565	653
250	280	10	12883	773	894
300	315	12	16733	1004	1161

Pressure loss charts

Pressure loss DN50/2"

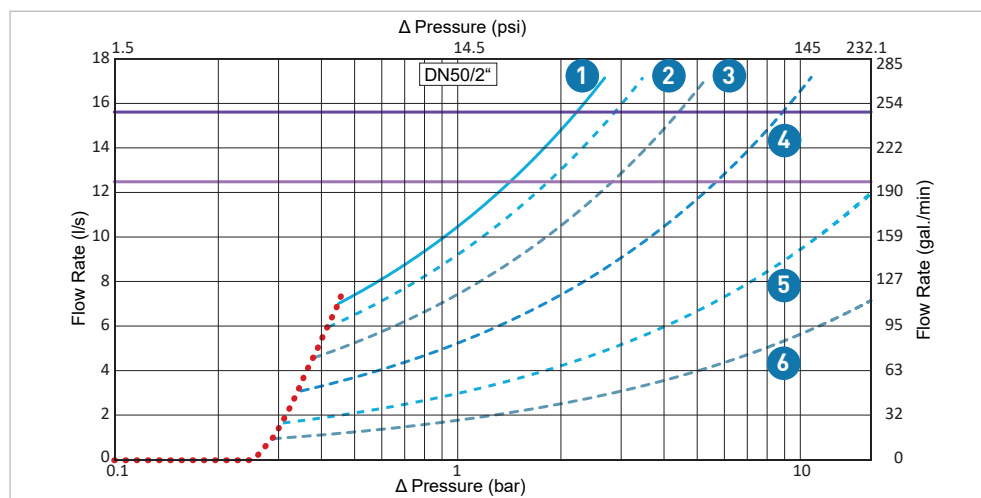

- 1 Maximum open
- 2 80% open
- 3 60% open
- 4 40% open
- 5 20% open
- 6 10% open
- Minimum pressure drop
- Maximum intermittent flow rate (7,5 m/s pipe velocity)
- Maximum continuous flow rate (6 m/s pipe velocity)

Pressure loss DN80/3"

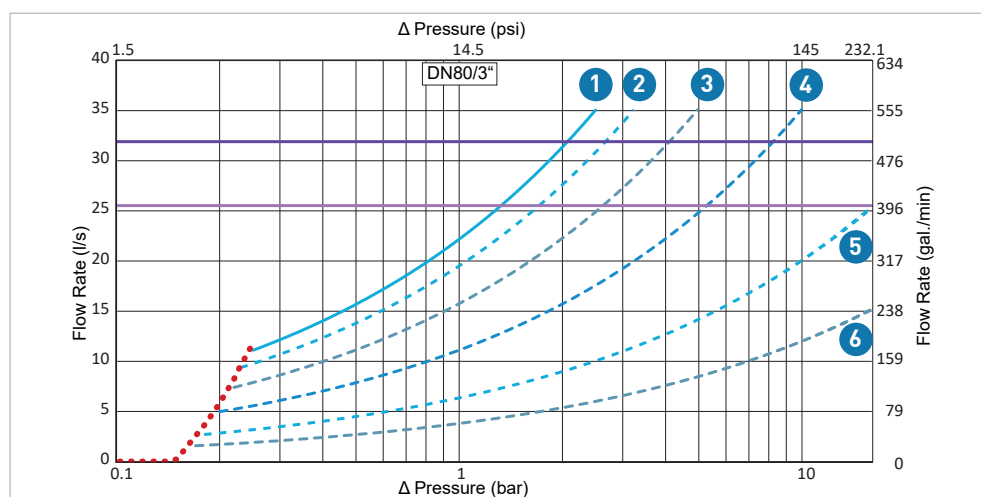

- 1 Maximum open
- 2 80% open
- 3 60% open
- 4 40% open
- 5 20% open
- 6 10% open
- Minimum pressure drop
- Maximum intermittent flow rate (7,5 m/s pipe velocity)
- Maximum continuous flow rate (6 m/s pipe velocity)

Pressure loss DN100/4"

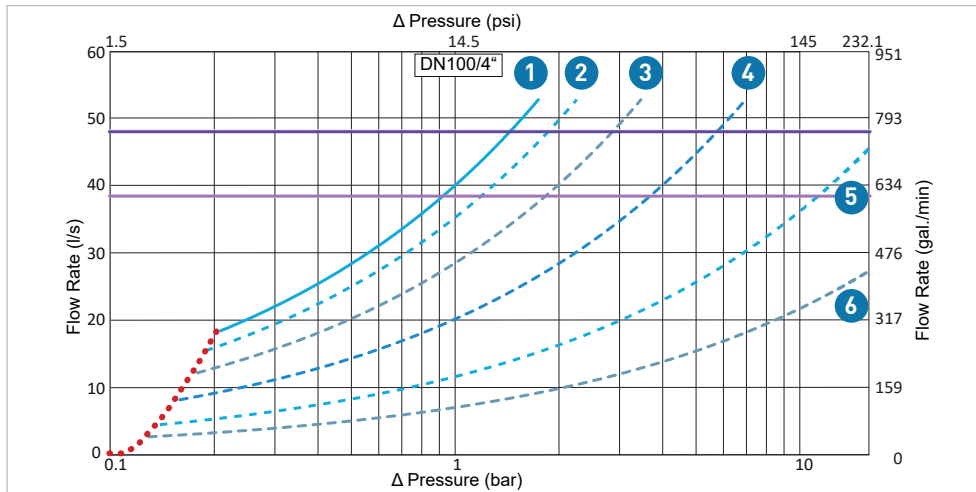

- 1 Maximum open
- 2 80% open
- 3 60% open
- 4 40% open
- 5 20% open
- 6 10% open
- Minimum pressure drop
- Maximum intermittent flow rate (7,5 m/s pipe velocity)
- Maximum continuous flow rate (6 m/s pipe velocity)

Pressure loss DN150/6"

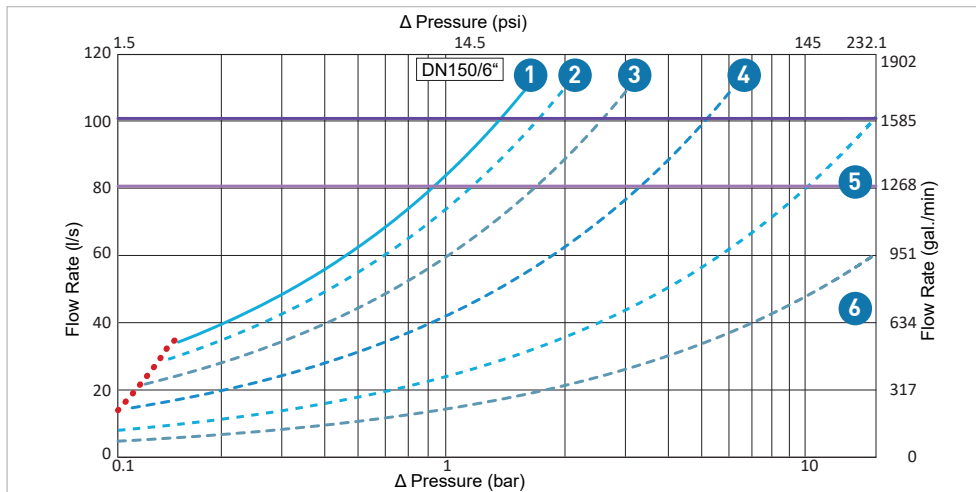

- 1 Maximum open
- 2 80% open
- 3 60% open
- 4 40% open
- 5 20% open
- 6 10% open
- Minimum pressure drop
- Maximum intermittent flow rate (7,5 m/s pipe velocity)
- Maximum continuous flow rate (6 m/s pipe velocity)

Pressure loss DN200/8"

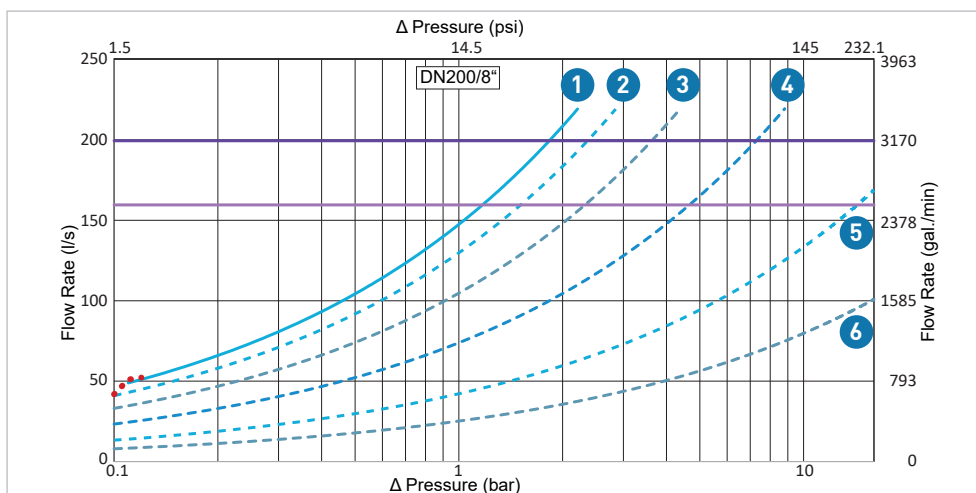

- 1 Maximum open
- 2 80% open
- 3 60% open
- 4 40% open
- 5 20% open
- 6 10% open
- Minimum pressure drop
- Maximum intermittent flow rate (7,5 m/s pipe velocity)
- Maximum continuous flow rate (6 m/s pipe velocity)

Pressure loss DN250/10"

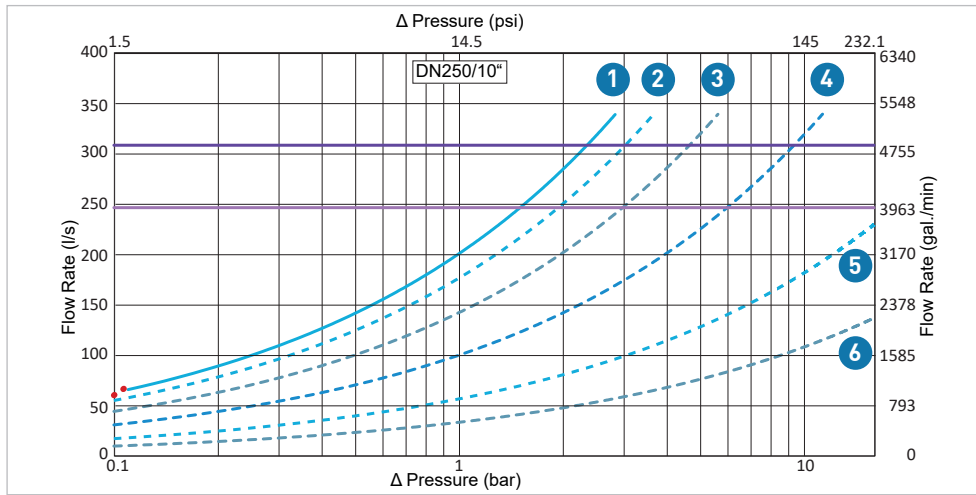

- 1 Maximum open
- 2 80% open
- 3 60% open
- 4 40% open
- 5 20% open
- 6 10% open
- Minimum pressure drop
- Maximum intermittent flow rate (7,5 m/s pipe velocity)
- Maximum continuous flow rate (6 m/s pipe velocity)

Pressure loss DN300/12"

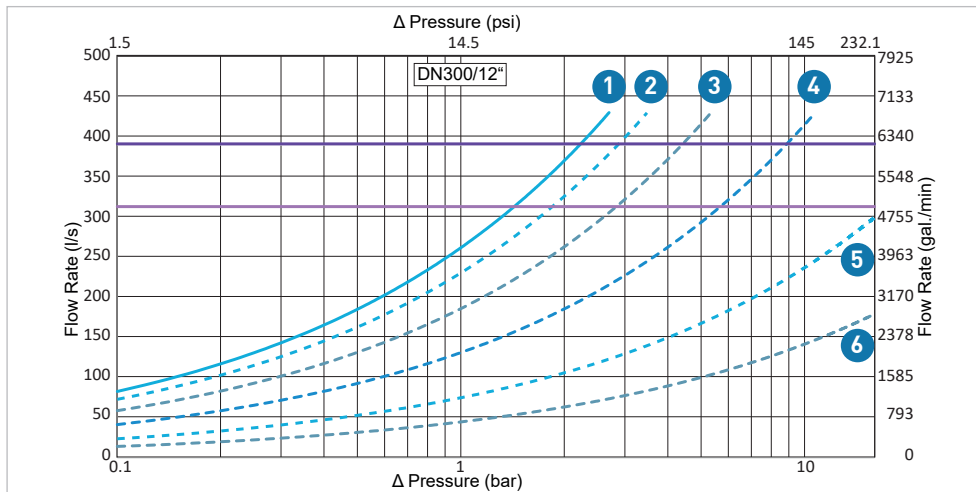

- 1 Maximum open
- 2 80% open
- 3 60% open
- 4 40% open
- 5 20% open
- 6 10% open
- Minimum pressure drop
- Maximum intermittent flow rate (7,5 m/s pipe velocity)
- Maximum continuous flow rate (6 m/s pipe velocity)

Cavitation

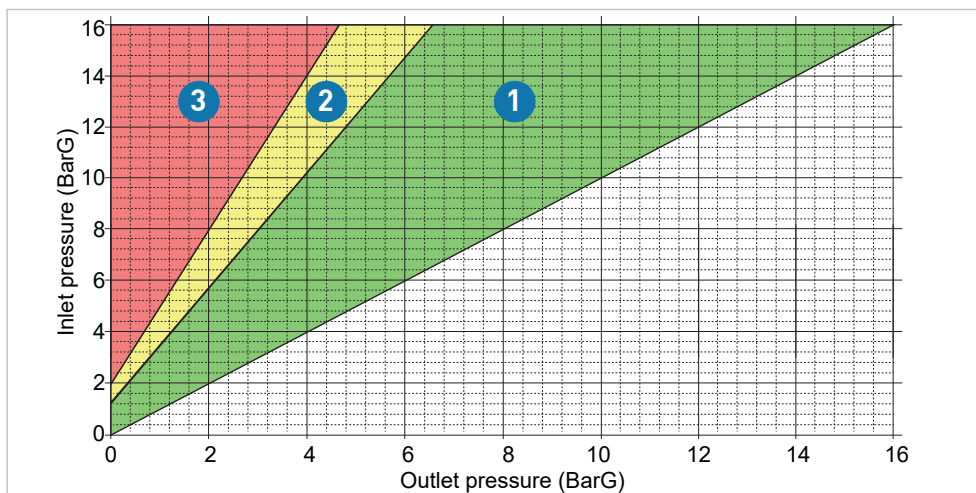

- 1 Safe operating region
- 2 Cavitation noise region
- 3 Cavitation damage region

Dimensions

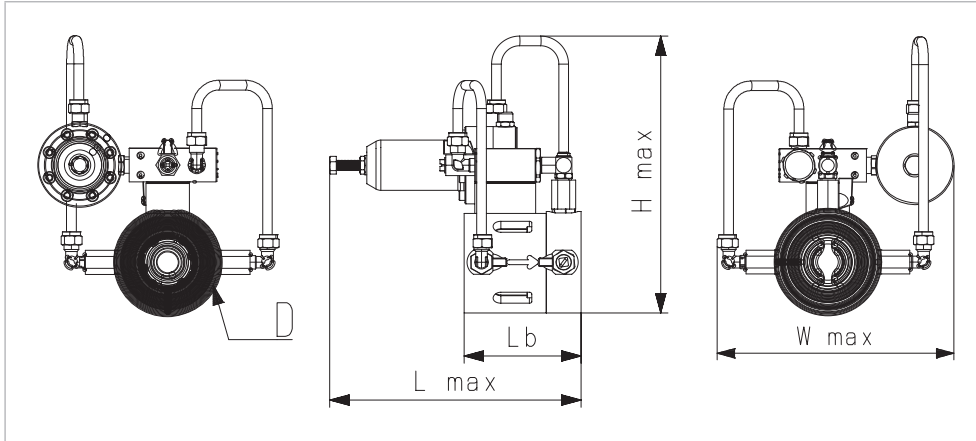

Dimensions			Housing dimensions					NPT Housing dimensions		
DN (mm)	Do2 (mm)	Inch (")	D (mm)	L max (mm)	Lb (mm)	H max (mm)	W max (mm)	Weight (kg)	H max (inch)	W max (inch)
50	63	2	105	266	121	283	240	5.2	12	10
80	90	3	134	289	135	318	253	6.1	13	11
100	110	4	162	287	155	337	274	7.6	14	11
150	160	6	218	289	230	385	340	12.7	16	14
200	225	8	275	298	298	406	485	22.3	18	21
250	280	10	328	348	348	510	550	34.8	20	24
300	315	12	378	398	398	596	640	51.0	22	25

Components

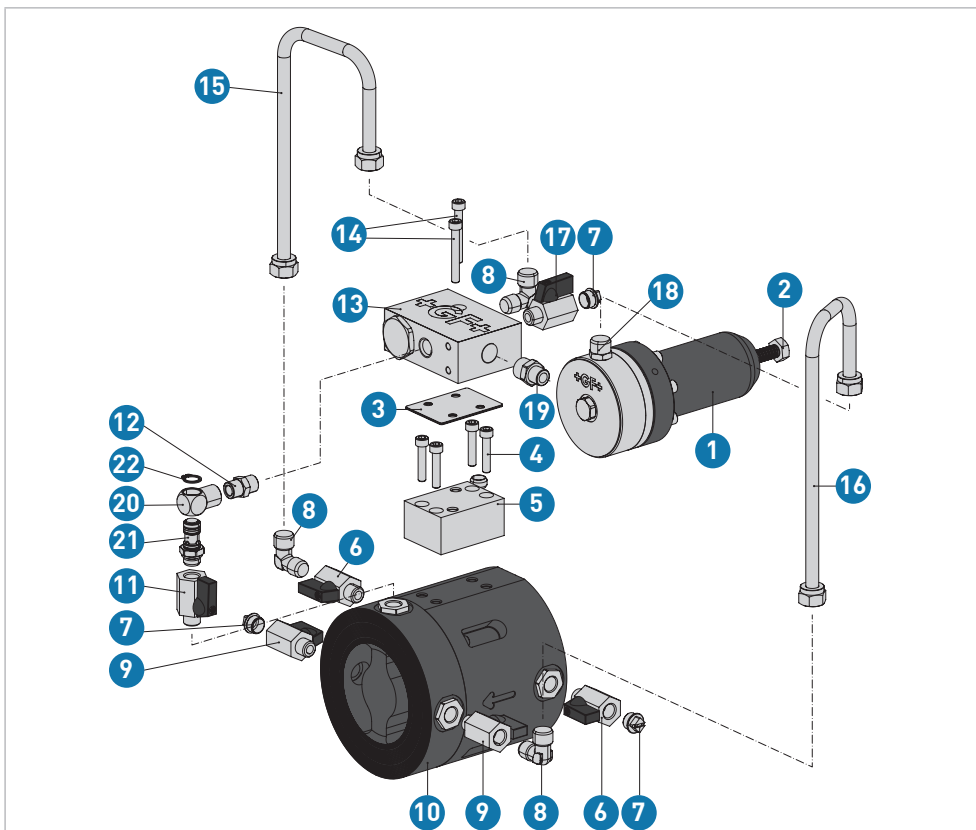

- 1 Pilot valve
- 2 Adjusting screw
- 3 Spacer plate
- 4 Socket head bolt M6x25
- 5 Control block base
- 6 Ball valve inlet
- 7 Sealing plug
- 8 90° Bolt connection
- 9 Ball valve outlet
- 10 Main body
- 11 Ball valve control space
- 12 Valve chamber transition nipple
- 13 Control block
- 14 Control block bolt connection
- 15 Inlet control line
- 16 Outlet control line
- 17 Ball valve control block
- 18 Screw-in connection, straight
- 19 Pilot transition nipple
- 20 Damping valve sleeve
- 21 Damping valve
- 22 Clamp ring

Article numbers

BSP version

DN (mm)	Code 0 - 3 (bar [g])	Code 1 - 8* (bar [g])	Code 1 - 13.5 (bar [g])	Code 1 - 16 (bar [g])
50	193 175 111	193 175 011		193 175 211
80	193 175 113	193 175 013		193 175 213
100	193 175 114	193 175 014		193 175 214
150	193 175 117	193 175 017		193 175 217
200		193 173 020	193 173 420	193 173 620
250		193 173 022	193 173 422	193 173 622
300		193 173 023	193 173 423	193 173 623

* 0 - 8.5 bar for DN200 - DN300

NPT version

Inch (")	Code 0 - 43.5 (psi [g])	Code 14.5 - 116* (psi [g])	Code 14.5 - 195 (psi [g])	Code 14.5 - 232 (psi [g])
2	193 174 811	193 174 711		193 174 911
3	193 174 812	193 174 713		193 174 913
4	193 174 812	193 174 714		193 174 914
6	193 174 817	193 174 717		193 174 917
8		193 174 020	193 174 420	193 174 620
10		193 174 022	193 174 422	193 174 622
12		193 174 023	193 174 423	193 174 623

* 0 - 123 psi for 8" - 12"

Pressure ranges of the pilot valve springs

Color coding Pilot valve spring	Pressure range Adjustable (bar [g])	Pressure range Adjustable (psi [g])	Sensitivity of the setting (bar/revolution)	Sensitivity of the setting (psi/revolution)
Silver	0 - 3*	0 - 43.5	0.18	2.6
Black**	1 - 8	14.5 - 116	0.43	6.2
Blue	1 - 13.5***	14.5 - 195***	0.65	9.4
Red	1 - 16	14.5 - 232	1.53	21.8

*DN50 - DN150 only

**Standard version, 0 - 8.5 bar / 14.5 - 123 psi for DN200-DN300

***DN200 - DN300 only

Co-developed with OFUI

The information and technical data (altogether "Data") herein are not binding, unless explicitly confirmed in writing. The Data neither constitutes any expressed, implied or warranted characteristics, nor guaranteed properties or a guaranteed durability. All Data is subject to modification. The General Terms and Conditions of Sale of Georg Fischer Piping Systems apply.

06/2024-A

© Georg Fischer Piping Systems Ltd, 8201 Schaffhausen/Switzerland

Tel. +41 52 631 11 11 • www.gfps.com • E-Mail: info.ps@georgfischer.com