

e-DIASTAR for types 514, 515 and 517



Diaphragm Valve type 514 with e-DIASTAR actuator

Product description

The e-DIASTAR system is based on the diaphragm Valve type 514 (threaded sockets) and type 515 (spigots), on which the electric actuator EA-MT is mounted. The diaphragm Valve type 517 (flange) can be retrofitted after installation. The electric actuator EA-MT opens and closes the diaphragm valve fully automatic.

The e-DIASTAR is used to regulate, close and control volume flows automatically. Especially when transporting contaminated, aggressive or abrasive media, this type of valve has decisive advantages thanks to its simple function and optimized construction. Only the valve body and the replaceable diaphragm are in contact with the medium.

Applications

- Chemical process industry
- Microelectronics
- Water treatment
- Cooling
- Control applications

Actuator benefits/features

- Multiturn actuator
- Adjustable integrated heating
- 7-segment error display
- Position feedback (open/close)
- Fully automatic end position teach-in
- Integrated emergency manual override
- Retrofit set includes: Conversion kit with drive, half shells and screws

Valve benefits/features

- Full plastic valve without metal screws
- No corrosion due to aggressive media/environment
- Constant leak-tightness in the event of changes in temperature without tightening screws
- Plastic-appropriate, highly stable connection of upper part and valve body by means of a buttress thread
- Maximum flow and linear characteristic curves for easier control
- Diaphragm geometry for longer service life

Possible flow media

- Contaminated, solid or ultrapure media

Technical data

The standard version of the EAMT electric actuator consists of the following elements:

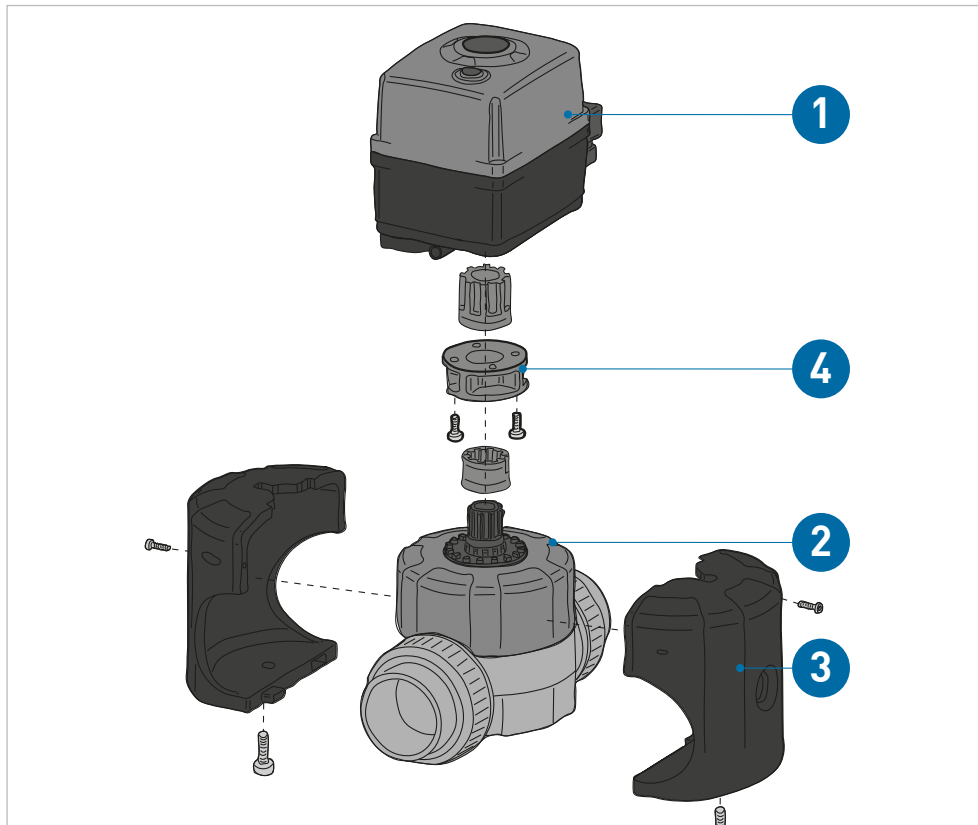

- 1 Electric actuator EAMT
- 2 Diaphragm valve
- 3 Assembly shells
- 4 Intermediate elements

Specification diaphragm valve

Dimensions	d32/DN25 and d63/DN50, ¾" - 2"	
Valve body materials	Type 514	PVC-U, PVC-C, ABS, PP-H, PVDF Retrofittable: PVDF-HP
	Type 515	PVC-U, PVC-C, ABS, PP-H, PVDF Retrofittable: PVDF-HP
	Type 517 (on request)	PVC-U, PVC-C, PP-H, PVDF
Housing nut materials	PPGF 30	
Gasket/diaphragm materials	EPDM, PTFE/EPDM, NBR, FKM, PTFE/FKM	
Pressure levels	DN25: PN10 DN50: PN6	
Connections	Type 514	Screw connection
	Type 515	Spigot
	Type 517 (on request)	Flange
Product standard	EN ISO 16138	
Test standard	ISO 9393-2, EN 12266-1 (leakage rate A)	
Approvals	ACS, FDA, DIBt	

Specification EAMT

Power input max.	65 VA
Current (calculated)	0.55A at 100V 0.24A at 230V 2.5A at 24V
Power Supply	AC: 100 – 230 V, 50/60 Hz AC/DC: 24 V, 50/60 Hz
Supply voltage tolerance	-10%...+15%
Mechanical interface	F05* (WS 11/14)
Duty cycle	50 %
Cycle time open/close	DN25: ≈ 85 sec. DN50: ≈ 130 sec.
Tested cycles (at 20 °C and Mdn)	5'000
Weight	2.2 kg / 4.85 lbs
Actuating angle	Multiturn
Protection class	IP 65 (IP67) ¹⁾ per EN 60529 Designed for wet & dry locations (NEC), designed for indoor use (UV light may cause discoloration)
Pollution degree	Operation: Pollution Level 3 Commissioning (open housing cover): Only in controlled environments of pollution level 2
Overload protection	Current/time dependent, resetting
Overvoltage category	II
Fuse	Internal: SMD fuse 2 A, not replaceable. Req. external breakers on all live wires: Rated Current: max. 16A Trip Curve: C, Standards Compliance: UL489, CSA C22.2 No. 5.1, IEC 60947-2
Ambient temp.	-10 °C to +50 °C (14°F to 122°F)
Max. installation altitude	2000m above sea level (AMSL)
Feedback relays	Mono-stable change-over contacts Either max 6A @ 230VAC or 24VDC, no mixed voltage potentials allowed!
Recommended connecting cable	AWG 18-16, UL/cUL AWM 4486 min. 125°C 1000V , outside diameter 8-13mm (cable glands), 4-9mm (DIN-connectors)
Allowable humidity	Max. 90 % relative humidity, non-condensing
Housing material	Housing: PP-GF (POLYFLAM, RPP 4225 CS1) Inspection glass: Udel P-1700 (CL2611) Assembly shells and intermediate elements: PPGF 30

¹⁾ When used with cable glands and vertical installation.

Dimensions

e-DIASTAR type 514 with solvent cement sockets metric

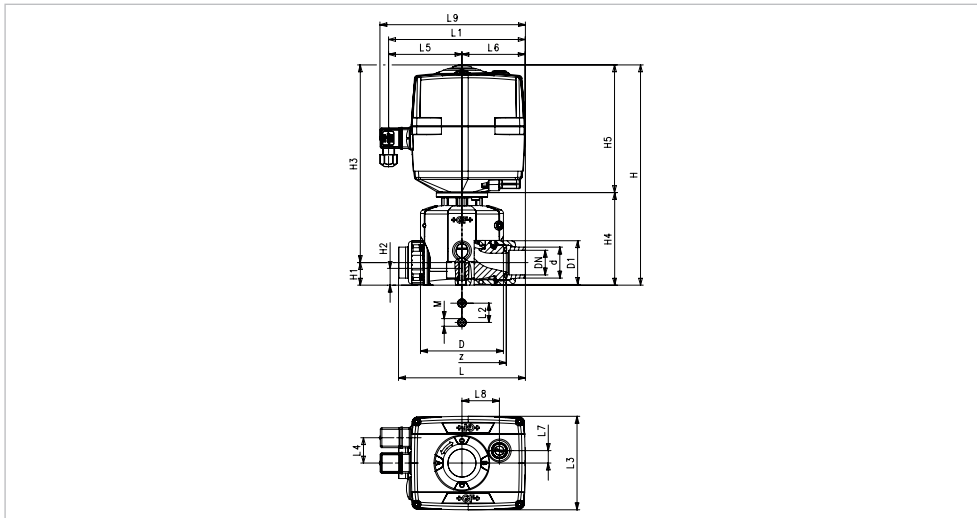

d (mm)	DN (mm)	DN (inch)	D1 (mm)	H (mm)	H1 (mm)	H2 (mm)	H3 (mm)	H4 (mm)	M (mm)	L (mm)	L1 (mm)
32	25	1	58	286	30	20	256	121	M6	166	180
63	50	2	101	341	52.5	28.5	288.5	176	M8	266	180

d (mm)	DN (mm)	DN (inch)	L2 (mm)	L3 (mm)	L4 (mm)	L5 (mm)	L6 (mm)	L7 (mm)	L8 (mm)	D (mm)
32	25	1	25	122	33	97	82.5	16	49	108.5
63	50	2	45	122	33	97	82.5	16	49	168

e-DIASTAR type 514 with solvent cement sockets BS

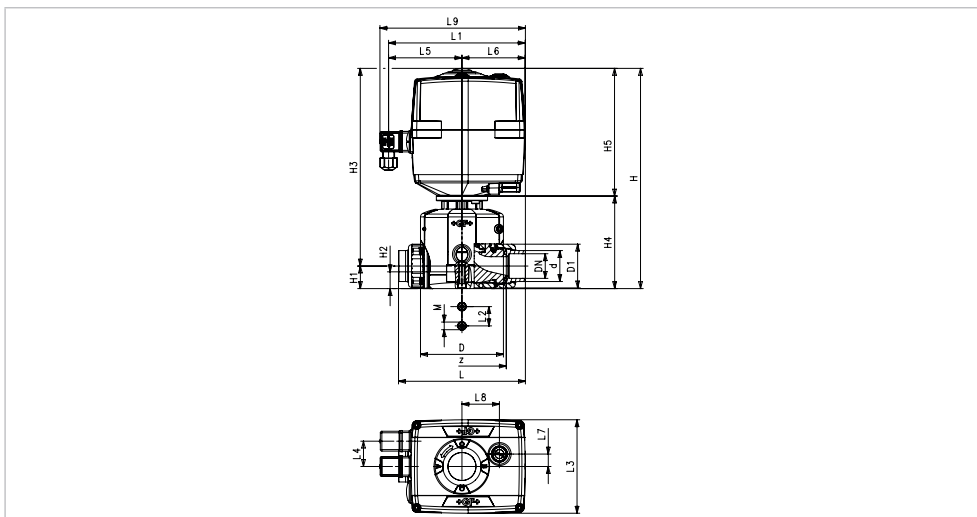

d (mm)	DN (mm)	DN (inch)	D1 (mm)	H (mm)	H1 (mm)	H2 (mm)	H3 (mm)	H4 (mm)	M (mm)	L (mm)	L1 (mm)
32	25	1	58	286	30	20	256	121	M6	170	180
63	50	2	101	341	52.5	28.5	288.5	176	M8	265	180

d (mm)	DN (mm)	DN (inch)	L2 (mm)	L3 (mm)	L4 (mm)	L5 (mm)	L6 (mm)	L7 (mm)	L8 (mm)	D (mm)
32	25	1	25	122	33	97	82.5	16	49	108.5
63	50	2	45	122	33	97	82.5	16	49	168

e-DIASTAR type 514 with solvent cement sockets ASTM

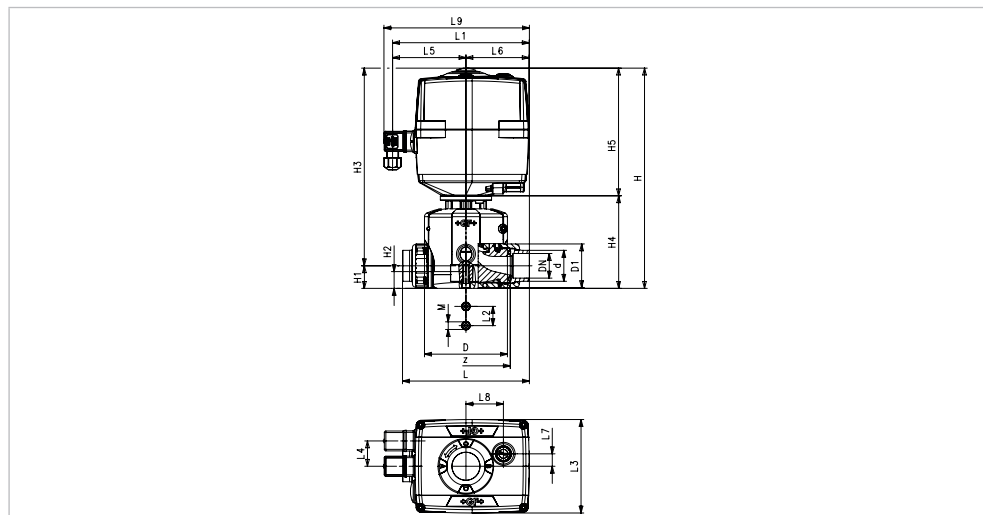

d (mm)	DN (mm)	DN (inch)	D1 (mm)	H (mm)	H1 (mm)	H2 (mm)	H3 (mm)	H4 (mm)	M (mm)	L (mm)	L1 (mm)
32	25	1	58	286	30	20	256	121	M6	166	180
63	50	2	101	341	52.5	28.5	288.5	176	M8	266	180

d (mm)	DN (mm)	DN (inch)	L2 (mm)	L3 (mm)	L4 (mm)	L5 (mm)	L6 (mm)	L7 (mm)	L8 (mm)	D (mm)
32	25	1	25	122	33	97	82.5	16	49	108.5
63	50	2	45	122	33	97	82.5	16	49	168

e-DIASTAR type 514 with solvent cement sockets JIS

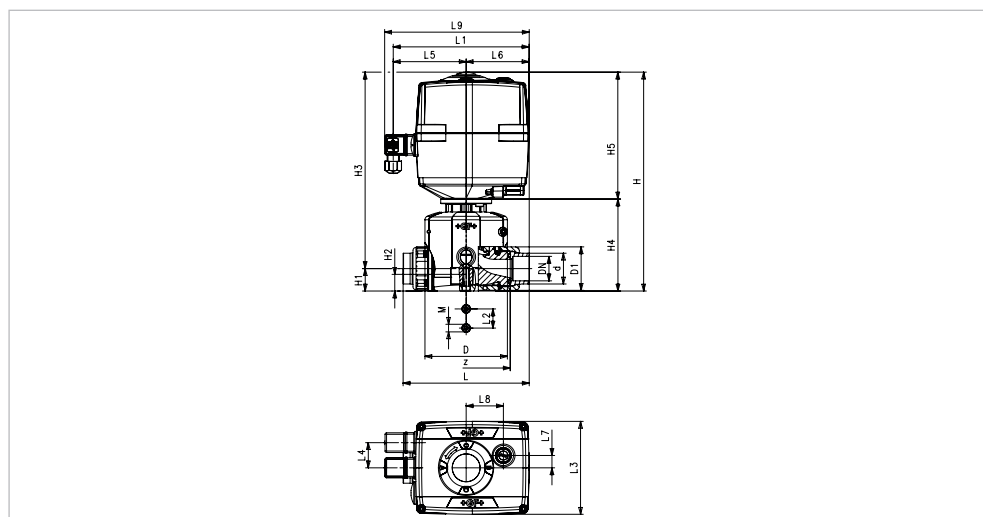

d (mm)	DN (mm)	DN (inch)	D1 (mm)	H (mm)	H1 (mm)	H2 (mm)	H3 (mm)	H4 (mm)	M (mm)	L (mm)	L1 (mm)
32	25	1	58	286	30	20	256	121	M6	170	180
63	50	2	101	341	52.5	28.5	288.5	176	M8	265	180

d (mm)	DN (mm)	DN (inch)	L2 (mm)	L3 (mm)	L4 (mm)	L5 (mm)	L6 (mm)	L7 (mm)	L8 (mm)	D (mm)
32	25	1	25	122	33	97	82.5	16	49	108.5
63	50	2	45	122	33	97	82.5	16	49	168

e-DIASTAR type 514 with fusion sockets metric

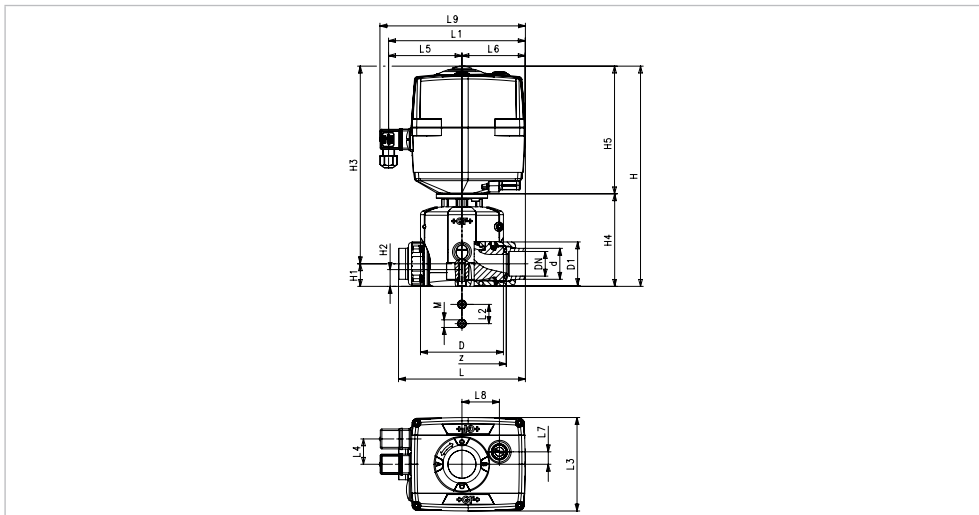

d (mm)	DN (mm)	DN (inch)	D1 (mm)	H (mm)	H1 (mm)	H2 (mm)	H3 (mm)	H4 (mm)	M (mm)	L (mm)	L1 (mm)
32	25	1	62	287	30	20	256	121	M6	166	180
63	50	2	105	341	52.5	28.5	288.5	176	M8	266	180

d (mm)	DN (mm)	DN (inch)	L2 (mm)	L3 (mm)	L4 (mm)	L5 (mm)	L6 (mm)	L7 (mm)	L8 (mm)	D (mm)
32	25	1	25	122	33	97	82.5	16	49	108.5
63	50	2	45	122	33	97	82.5	16	49	168

e-DIASTAR type 515 with solvent cement spigots metric

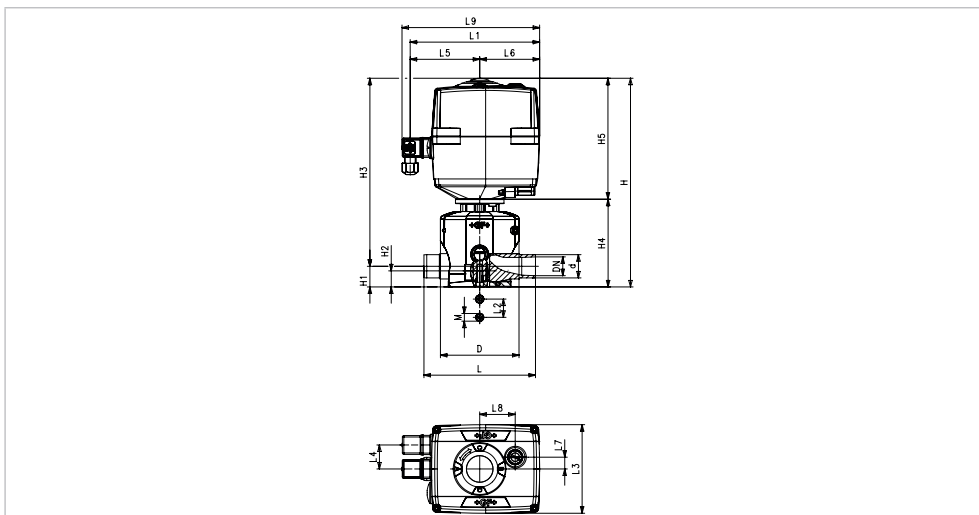

d (mm)	DN (mm)	DN (inch)	D1 (mm)	H (mm)	H1 (mm)	H2 (mm)	H3 (mm)	H4 (mm)	M (mm)	L (mm)	L1 (mm)
32	25	1	58	286	30	20	256	121	M6	154	180
63	50	2	101	341	52.5	28.5	288.5	176	M8	223	180

d (mm)	DN (mm)	DN (inch)	L2 (mm)	L3 (mm)	L4 (mm)	L5 (mm)	L6 (mm)	L7 (mm)	L8 (mm)	D (mm)
32	25	1	25	122	33	97	82.5	16	49	108.5
63	50	2	45	122	33	97	82.5	16	49	168

e-DIASTAR type 51x with socket fusion spigots metric

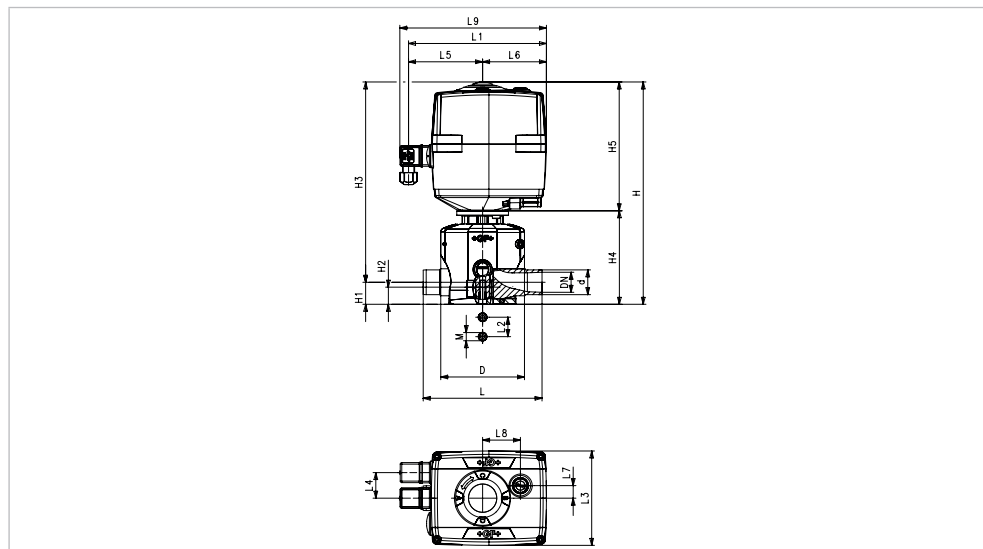

d (mm)	DN (mm)	DN (inch)	D1 (mm)	H (mm)	H1 (mm)	H2 (mm)	H3 (mm)	H4 (mm)	M (mm)	L (mm)	L1 (mm)
32	25	1	58	286	30	20	256	121	M6	154	180
63	50	2	101	341	52.5	28.5	288.5	176	M8	223	180

d (mm)	DN (mm)	DN (inch)	L2 (mm)	L3 (mm)	L4 (mm)	L5 (mm)	L6 (mm)	L7 (mm)	L8 (mm)	D (mm)
32	25	1	25	122	33	97	82.5	16	49	108.5
63	50	2	45	122	33	97	82.5	16	49	168

Kv 100-values

Type 514 – 517

Dim. (mm)	DN (mm)	Inch (")	kv 100 (l/min)	Cv 100 (US gal/min)	kv 100 (m ³ /h)
32	25	1	442	31	27
63	50	2	1575	109	95

Accessories

- Fail-safe return unit with integrated battery pack
- External fail-safe return unit
- Positioner 4-20 mA
- EA Demo Box

i For further information on accessories, refer to the online product catalog at www.gfps.com

The information and technical data (altogether "Data") herein are not binding, unless explicitly confirmed in writing. The Data neither constitutes any expressed, implied or warranted characteristics, nor guaranteed properties or a guaranteed durability. All Data is subject to modification. The General Terms and Conditions of Sale of Georg Fischer Piping Systems apply.

02/2025-A

© Georg Fischer Piping Systems Ltd, 8201 Schaffhausen/Switzerland
Tel. +41 52 631 11 11 • www.gfps.com • E-Mail: info.ps@georgfischer.com