

Ball Valve type 546 Pro

Ball Valve type 546 Pro, manually operated



Type 546 Pro
manually operated

Product description

The Ball Valve type 546 Pro is the ideal valve for use in applications ranging from simple water applications right up to demanding chemical processes. Its modular construction guarantees simple operation, flexibility, universal automation options and the greatest possible process safety.

Function

The ball valve uses a rotating ball with a hole through it that allows straight-through flow in the open position and shuts off flow when the ball is rotated 90°. This valve is mainly used for open/close functions, and for regulating applications.

Benefits/features

The Ball Valve type 546 Pro modular design always adapts the actual requirements. Whether electric, pneumatic or manual operation, including optional accessories, it flexibly meets all requirements.

- Lockable lever equipped as standard
- Manual valve or actuated valve with/without electrical position feedback
- Ergonomic hand lever with integrated tool to open the union bushing
- Labeling in lever (optional)
- Integrated fixation system with mounted threaded inserts as standard
- Spacers keep the line of the piping system and simplify installation
- Individual online configuration is possible
- Unique Data Matrix Code for traceability
- Oil-free and LABS-cleaned version
- Very high flow rate
- Universal interface makes a combination with all actuators possible
- Manual spring return unit (dead man lever)
- Relief well to avoid gas accumulation possible (e.g. for H₂O₂)
- Version with linear flow characteristic available due to special ball (opening angle scaled in 0 % - 100 % on index plate)

Applications

- Chemical process industry
- Water treatment
- Microelectronics
- Measurement and control
- Shipbuilding
- Food & beverage

Flow media

Neutral and aggressive media with a small amount of particles/solids. The chemical resistance is independent of the selected valve material ([see online tool ChemRes PLUS](#)).

Transport of compressed air

Ball valves type 546 Pro are suitable for compressed air regulation up to 10 bar (at 20 °C). The compressed air must be dry and free of oil. For this application PP-H is recommended as valve body material and FKM* for the gaskets.

Suitable piping systems are ecoFIT (PE) or INSTAFLEX (PB). The ball valve type 546 Pro is available with suitable connection parts.

*FKM is suitable for compressed air containing mineral oil. Some ester oils can attack the material FKM, in such cases the use of EPDM gaskets is recommended.

Technical data

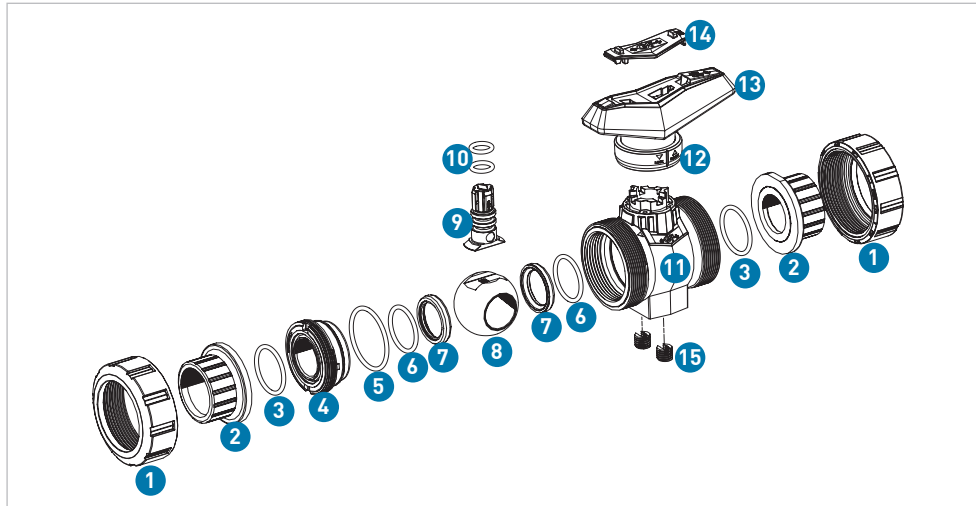

- 1 Union nut
- 2 Connecting part
- 3 Union seal
- 4 Union bush
- 5 Body seal
- 6 Backing seal
- 7 Ball seat
- 8 Ball
- 9 Stem
- 10 Stem seals
- 11 Body
- 12 Locking ring
- 13 Lever (lockable)
- 14 Lever clip
- 15 Threaded insert

Specification

Dimensions	d16/DN10 – d110/DN100 (d160/DN150), 3/8" – 4" (6")	
Materials	Valve body	PVC-U, PVC-C, ABS, PP-H, PVDF
	Lever	PP-GF30
Gasket materials	O-rings	EPDM, FKM, FFKM
	Ball seat	PTFE, PVDF
Pressure levels	ABS / PP-H	PN10
	PVC-U / PVC-C / PVDF	PN16
Connections	Fusion / solvent cement sockets	ISO, ASTM, JIS, BS
	Fusion / solvent cement spigot	ISO
	Threaded socket	Rp, NPT, Rc
	Backing flange	ISO, ANSI, BS, JIS
	Butt fusion spigots	SDR11 and SDR17.6
	PE100 electrofusion spigot or butt fusion spigot	SDR11 and SDR17.6
Actuation variants	Manually operated (lockable hand lever)	
	Pneumatic FC, FO, DA with and without manual override	
	Electrical AC: 100 – 230 V, AC/DC: 24 V, with / without manual override	
Flange standards	EN 1092 PN 10, ASME B16.5 Class 150, BS 1560-3.2 Class 150, JIS B2220 10K	
Third-party actuators	EN ISO 5211	
Marking	DataMatrix-Code with production data	
Product standard	EN ISO 16135	
Test standard	ISO 9393-2, EN 12266-1 (leakage rate A)	
Approvals	ACS, D.M. 174, DNV, FDA, QAP/ITP, NSF/ANSI, SIL, WRAS, ABS, BV, DiBT, RINA, LR	

Kv 100 values

DN (mm)	Inch (inch)	d (mm)	Type 546 Pro		
			Kv 100 (l/min)	Cv 100 (US gal/min)	Kv 100 (m ³ /h)
10	3/8	16	70	4.9	4
15	1/2	20	185	12.9	11
20	3/4	25	350	24.5	21
25	1	32	700	49.0	42
32	1 1/4	40	1000	70.0	60
40	1 1/2	50	1600	112.0	96
50	2	63	3100	217.1	186
65	2 1/2	75	5000	350.0	300
80	3	90	7000	490.0	420
100	4	110	11000	770.0	660

Flow characteristics type 546 Pro

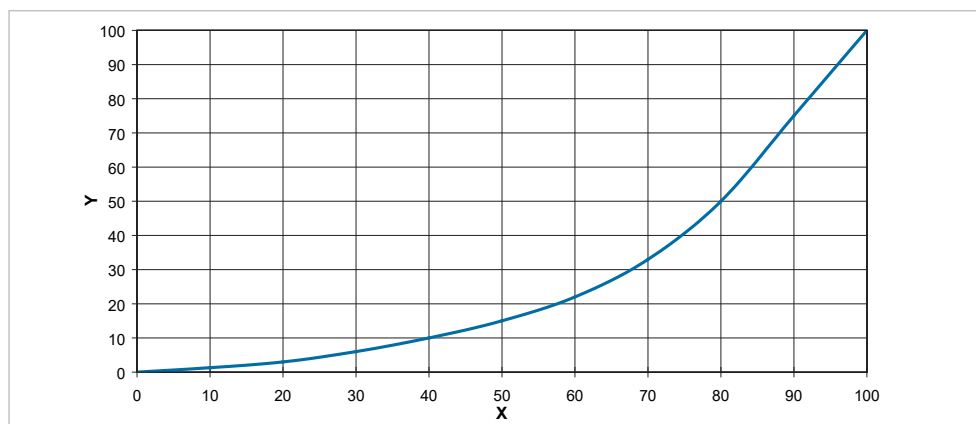

X Opening angle (%)
Y Kv, Cv value (%)

Pressure-temperature diagrams

The following pressure-temperature diagrams are based on a service life of 25 years and water or similar media.

T Temperature (°C, °F)

P Permissible pressure (bar, psi)

PVC-U

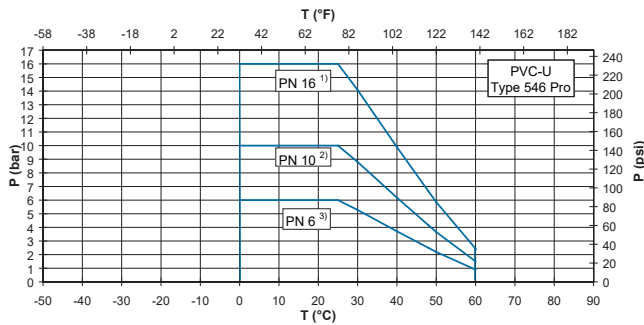

- 1) The central part of the ball valve is designed for the nominal pressure PN16
- 2) Depending on the connection, the nominal pressure is reduced to PN10
- 3) Depending on the connection, the nominal pressure is reduced to PN6

PVC-C

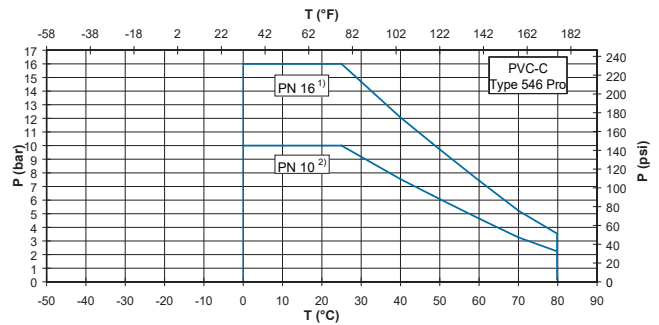

- 1) The central part of the ball valve is designed for the nominal pressure PN16
- 2) Depending on the connection, the nominal pressure is reduced to PN10

ABS

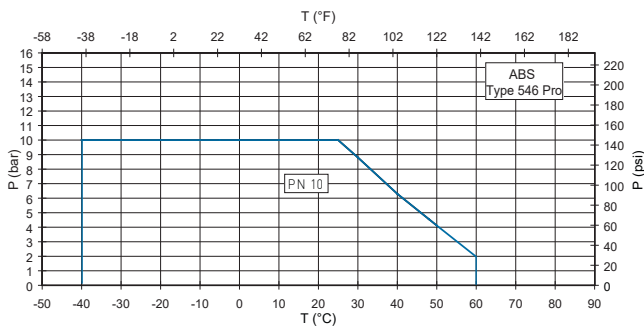

PP

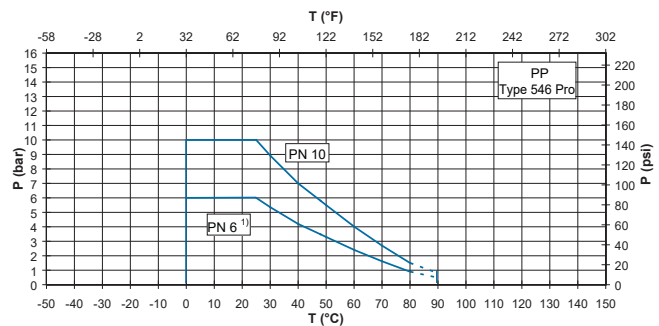

- 1) For example, ball valve with butt fusion spigot PP or PE100, SDR 17

PVDF

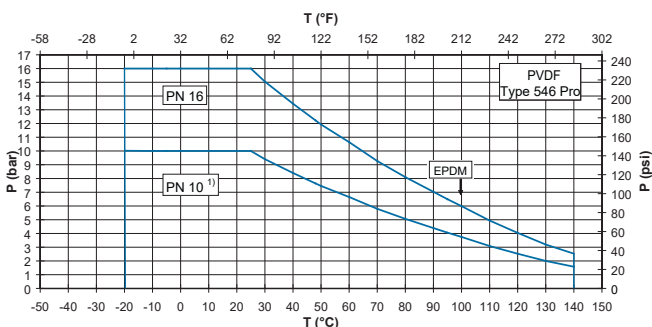

- 1) For example, ball valve with threaded socket EPDM gasket up to max. 100 °C

Pressure losses

d16/DN10 – d63/DN50

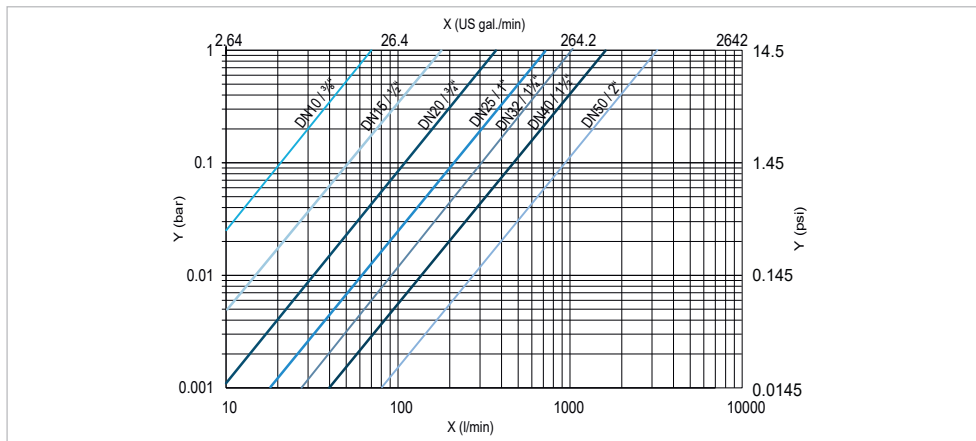

- X Flow rate (l/min, US gal/min)
- Y Pressure loss Δp (bar, psi)

d75/DN65 – DN100

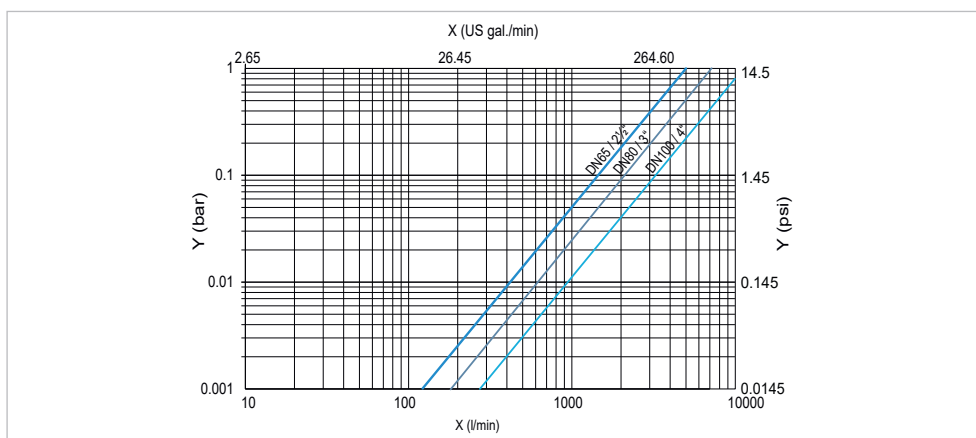

- X Flow rate (l/min, US gal/min)
- Y Pressure loss Δp (bar, psi)

Operating torque

DN10 – DN50

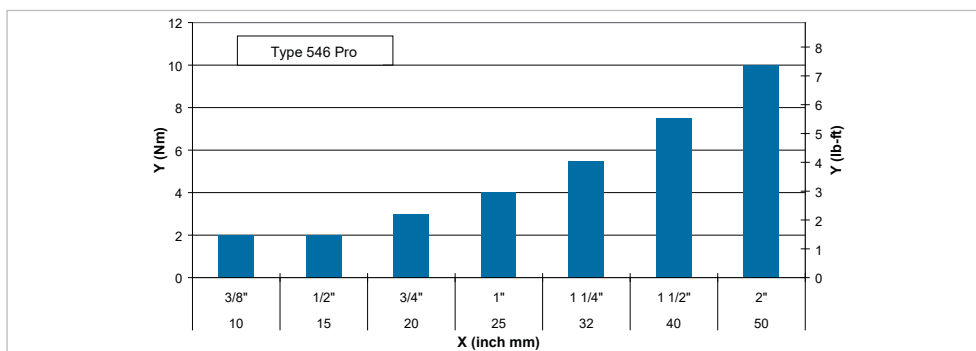

- X Nominal diameter DN (mm, inch)
 - Y Tightening torque (Nm, lb-ft)
- Average values at nominal pressure. Depending on the application (e.g. operating speed, fluid, temperature, etc.) about 2 times the operating torque should be taken for sizing actuators.

DN65 – DN100

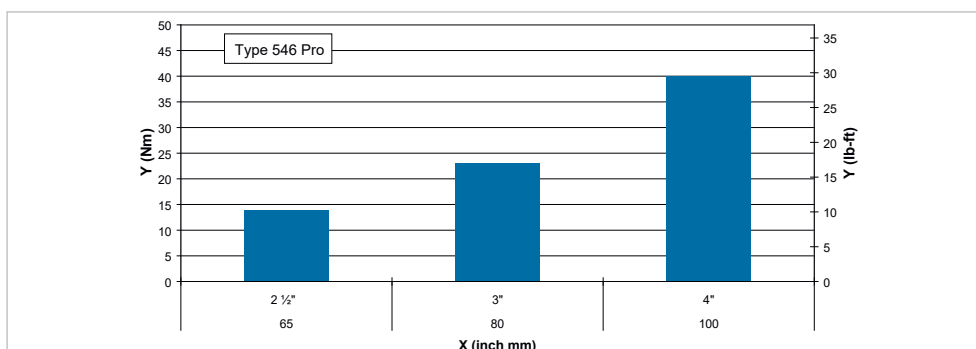

- X Nominal diameter DN (mm, inch)
 - Y Tightening torque (Nm, lb-ft)
- Average values at nominal pressure. Depending on the application (e.g. operating speed, fluid, temperature, etc.) about 2 times the operating torque should be taken for sizing actuators.

Reference values for tightening torque of screws

Flange connections with profile flange seal or flat gaskets

d (mm)	DN (mm)	Inch (inch)	Total number of screws (for 2 flange connections) standard nut ¹⁾	Torque (Reference values) Profile flange gasket ²⁾		Torque (Reference values) Flat gasket	
				(Nm)	(lb-ft)	(Nm)	(lb-ft)
20	15	½	8 x M12 x 50	10	7.4	10	7.4
25	20	¾	8 x M12 x 55	10	7.4	10	7.4
32	25	1	8 x M12 x 60	10	7.4	15	11
40	32	1 ¼	8 x M16 x 70	15	11	20	15
50	40	1 ½	8 x M16 x 70	15	11	25	18
63	50	2	8 x M16 x 80	20	15	35	26
75	65	2 ½	8 x M16 x 90	25	18	50	37
90	80	3	16 x M16 x 100	15	11	30	22
110	100	4	16 x M20 x 130	20	15	35	26

¹⁾ For Type 546 Pro connecting parts made of PP in combination with backing flanges, use half of the standard nut height

²⁾ Preferred gasket Type (suited for plastics)

Technical basics

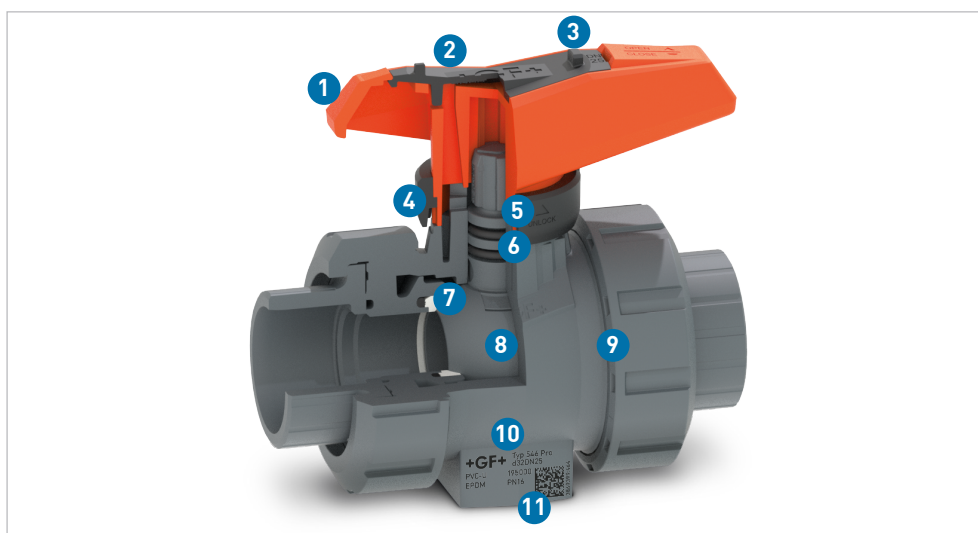

- 1 Ergonomic lever, lockable as standard
- 2 Quick-label on request
- 3 Integrated union bush tool
- 4 Interface for flexible automation and accessories
- 5 Reinforced security break point in the stem interface
- 6 Double stem seals
- 7 Dynamic backing seal
- 8 Smooth spherical surface
- 9 Saw tooth thread suitable for plastics
- 10 Fastening system with integrated threaded bushes
- 11 Data-Matrix-Code

With the backing seals, the ball has a floating position. This results in preloading and hence a constant seal. Stem, backing, housing and connection seals are made of EPDM or FKM.

The stems with predefined break point above the upper O-ring help prevent leaks to the outside in case of damage for manual valves. The new designed security break point in the interface allows the user to replace the coupling piece within a few minutes and without interruption if an automated valve is subject to wear.

i All ball valves in DN10 – 100 are available as radially removable valves with two threaded connections according to EN ISO 16135.

Union bushing

The design of the hand lever serves as a tool for installing the union bushings. The union bushing has a reverse thread in order to avoid unintentional opening when removing the coupling nuts or the thread connections.

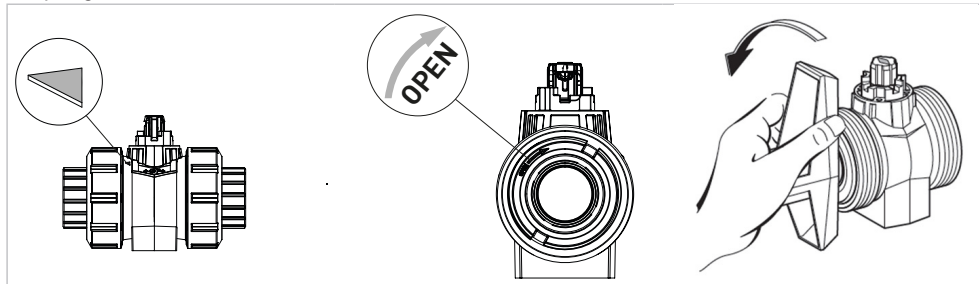

Locking function

Move the ball valve to the desired open or closed position and press down the locking ring. Attach lock to eye to protect lever from unauthorized actuation.

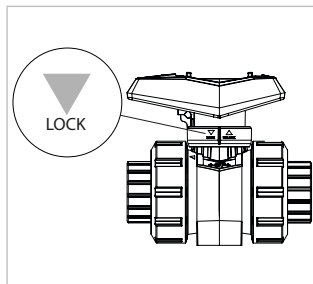

Valve handling

Removing the lever

When removing the lever, the locking ring must be in the open position (top).

Installation notes

When installing the ball valve, ensure that it is always installed into the system in an opened ball position.

Selection of lubricant

All seals should be lubricated with a silicone-based grease. Using the wrong lubricants can damage the material of the ball valve or seals.

- Mineral oil-based and Vaseline (petrolatum) are not appropriate.
- For silicone-free ball valves, please consult the special manufacturer's instructions.

Maintenance notes

Ball valves require no maintenance under normal operating conditions (clear water). However, the following measures must be considered:

- Regularly check that no medium escapes to the outside.
- We recommend a function test for ball type valves that are kept permanently in the same position 1 – 2 times per year to check functionality.

 Installation and maintenance must be performed according to the corresponding installation instructions. The installation manual is included with the product, see also the online product catalogue at www.gfps.com

Design type 546 Pro with linear flow characteristics

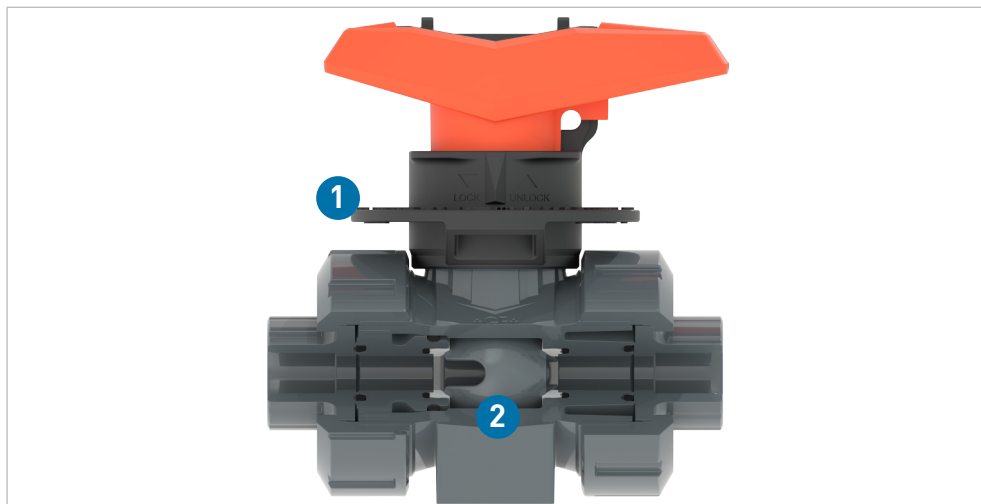

- 1 Ball with linear flow characteristic
- 2 Special index plate with opening angle in %

Dimensions

Ball Valve type 546 Pro with solvent cement spigots, metric

d (mm)	DN (mm)	Size (inch)	DE1 (mm)	M (mm)	M1 (mm)	M2 (mm)	B3 (mm)	G (mm)	H4 (mm)	H (mm)	H1 (mm)	L (mm)	Lz (mm)	s1 (mm)	z (mm)
16	10	3/8	50	82	35	47	25	M6	12	60.5	27	114	28	3	88
20	15	1/2	50	82	35	47	25	M6	12	60.5	27	124	28	3	96
25	20	3/4	58	106	44	62	25	M6	12	74	30	144	33	3	112
32	25	1	68	106	44	62	25	M8	12	80	36	154	36	4	118
40	32	1 1/4	84	131	57	74	45	M8	15	95	44	174	43	4	134
50	40	1 1/2	97	131	57	74	45	M8	15	101.5	51	194	45	5	148
63	50	2	124	152	66	86	45	M8	15	116.5	64	224	51	7	170
75	65	2 1/2	166	270	64	205	70	M8	15	169	85	284	68	8.5	194
90	80	3	200	270	64	205	70	M8	15	180	105	300	71	10	196
110	100	4	238	326	71	255	120	M12	22	194	123	340	82	12	212

Dimensions based on configuration with PVC-U ball valve

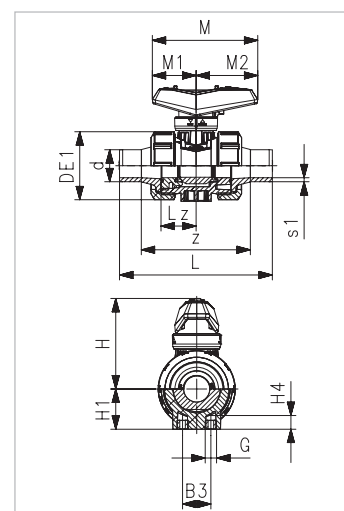

Ball Valve type 546 Pro with socket fusion spigots, metric

d (mm)	DN (mm)	Size (inch)	DE1 (mm)	M (mm)	M1 (mm)	M2 (mm)	B3 (mm)	G (mm)	H4 (mm)	H (mm)	H1 (mm)	L (mm)	Lz (mm)	s1 (mm)	z (mm)
16	10	3/8	50	82	35	47	25	M6	12	60.5	27	110	28	3	84
20	15	1/2	50	82	35	47	25	M6	12	60.5	27	120	28	3	92
25	20	3/4	58	106	44	62	25	M6	12	74	30	139	33	3	107
32	25	1	68	106	44	62	25	M8	12	80	36	150	36	4	114
40	32	1 1/4	84	131	57	74	45	M8	15	95	44	170	43	4	130
50	40	1 1/2	97	131	57	74	45	M8	15	101.5	51	190	45	5	144
63	50	2	124	152	66	86	45	M8	15	116.5	64	220	51	7	166
75	65	2 1/2	166	270	64	205	70	M8	15	169	85	280	68	8.5	190
90	80	3	200	270	64	205	70	M8	15	180	105	196	71	10	92
110	100	4	238	326	71	255	120	M12	22	194	123	336	82	12	208

Dimensions based on configuration with PP-H ball valve

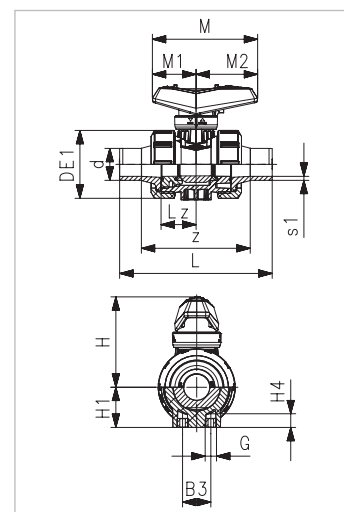

Ball Valve type 546 Pro with solvent cement sockets, metric

d (mm)	DN (mm)	Size (inch)	DE1 (mm)	M (mm)	M1 (mm)	M2 (mm)	B3 (mm)	G (mm)	H4 (mm)	H (mm)	H1 (mm)	L (mm)	Lz (mm)	z (mm)
16	10	3/8	50	82	35	47	25	M6	12	60.5	27	92	28	64
20	15	1/2	50	82	35	47	25	M6	12	60.5	27	95	28	64
25	20	3/4	58	106	44	62	25	M6	12	74	30	110	33	72
32	25	1	68	106	44	62	25	M8	12	80	36	123	36	79
40	32	1 1/4	84	131	57	74	45	M8	15	95	44	146	43	94
50	40	1 1/2	97	131	57	74	45	M8	15	101.5	51	157	45	95
63	50	2	124	152	66	86	45	M8	15	116.5	64	183	51	107
75	65	2 1/2	166	270	64	205	70	M8	15	169	85	233	68	144
90	80	3	200	270	64	205	70	M8	15	180	105	254	71	151
110	100	4	238	326	71	255	120	M12	22	194	123	301	82	174

Dimensions based on configuration with PVC-U ball valve

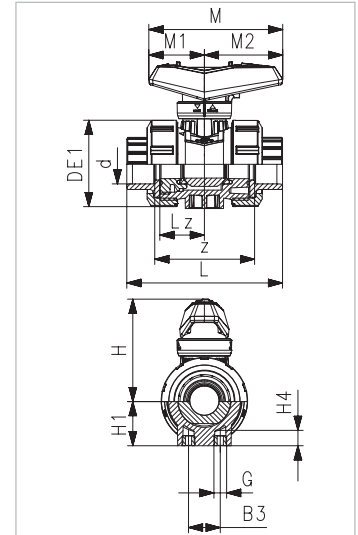

Ball Valve type 546 Pro with fusion sockets, metric

d (mm)	DN (mm)	Size (inch)	DE1 (mm)	M (mm)	M1 (mm)	M2 (mm)	B3 (mm)	G (mm)	H4 (mm)	H (mm)	H1 (mm)	L (mm)	Lz (mm)	z (mm)
16	10	3/8	50	82	35	47	25	M6	12	60.5	27	93	28	67
20	15	1/2	50	82	35	47	25	M6	12	60.5	27	95	28	66
25	20	3/4	58	106	44	62	25	M6	12	74	30	109	33	77
32	25	1	68	106	44	62	25	M8	12	80	36	119	36	83
40	32	1 1/4	84	131	57	74	45	M8	15	95	44	135	43	99
50	40	1 1/2	97	131	57	74	45	M8	15	101.5	51	147	45	105
63	50	2	124	152	66	86	45	M8	15	116.5	64	168	51	117
75	65	2 1/2	166	270	64	205	70	M8	15	169	85	233	68	167
90	80	3	200	270	64	205	70	M8	15	180	105	254	71	180
110	100	4	238	326	71	255	120	M12	22	194	123	301	82	215

Dimensions based on configuration with PVC-U ball valve

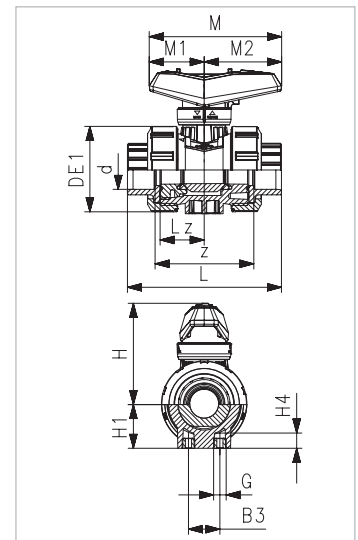

Ball Valve type 546 Pro with threaded sockets, ISO, JIS, ASTM

d (mm)	DN (mm)	Size (inch)	DE1 (mm)	M (mm)	M1 (mm)	M2 (mm)	B3 (mm)	G (mm)	H4 (mm)	H (mm)	H1 (mm)	L (mm)	Lz (mm)	z (mm)
16	10	3/8	50	82	35	47	25	M6	12	60.5	27	95	28	69
20	15	1/2	50	82	35	47	25	M6	12	60.5	27	100	28	67
25	20	3/4	58	106	44	62	25	M6	12	74	30	114	33	78
32	25	1	68	106	44	62	25	M8	12	80	36	127	36	85
40	32	1 1/4	84	131	57	74	45	M8	15	95	44	146	43	100
50	40	1 1/2	97	131	57	74	45	M8	15	101.5	51	152	45	106
63	50	2	124	152	66	86	45	M8	15	116.5	64	177	51	121
75	65	2 1/2	166	270	64	205	70	M8	15	169	85	233	68	144
90	80	3	200	270	64	205	70	M8	15	180	105	254	71	151
110	100	4	238	326	71	255	120	M12	22	194	123	301	82	174

Dimensions based on configuration with PVC-U ball valve

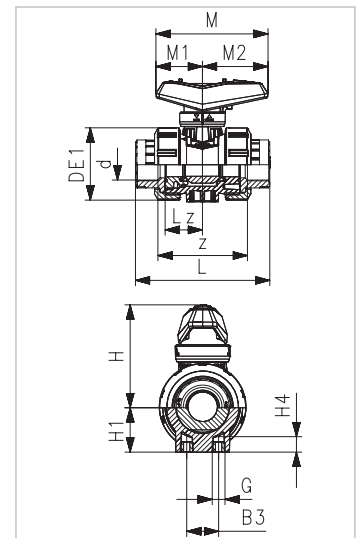

Ball Valve type 546 Pro with butt fusion spigots short, SDR11, metric

d (mm)	DN (mm)	Size (inch)	DE1 (mm)	M (mm)	M1 (mm)	M2 (mm)	B3 (mm)	G (mm)	H4 (mm)	H (mm)	H1 (mm)	L (mm)	Lz (mm)	s1 (mm)
20	15	½	50	82	35	47	25	M6	12	60.5	27	130	28	1.9
25	20	¾	58	106	44	62	25	M6	12	74	30	143	33	2.3
32	25	1	68	106	44	62	25	M8	12	80	36	150	36	3
40	32	1 ¼	84	131	57	74	45	M8	15	95	44	171	43	3.7
50	40	1 ½	97	131	57	74	45	M8	15	101.5	51	191	45	4.6
63	50	2	124	152	66	86	45	M8	15	116.5	64	220	51	5.8
75	65	2 ½	166	270	64	205	70	M8	15	169	85	266	68	8.2
90	80	3	200	270	64	205	70	M8	15	180	105	264	71	10
110	100	4	238	326	71	255	120	M12	22	194	123	301	82	12

Dimensions based on configuration with PVC-U ball valve

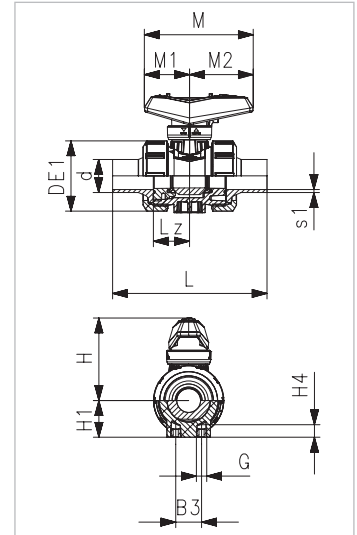

Ball Valve type 546 Pro with butt fusion spigots short, SDR17.6, metric

d (mm)	DN (mm)	Size (inch)	DE1 (mm)	M (mm)	M1 (mm)	M2 (mm)	B3 (mm)	G (mm)	H4 (mm)	H (mm)	H1 (mm)	L (mm)	Lz (mm)	s1 (mm)
50	40	1 ½	97	131	57	74	45	M8	15	101.5	51	191	45	2.9
63	50	2	124	152	66	86	45	M8	15	116.5	64	220	51	3.6
75	65	2 ½	166	270	64	205	70	M8	15	169	85	266	68	4.6
90	80	3	200	270	64	205	70	M8	15	180	105	264	71	5.5
110	100	4	238	326	71	255	120	M12	22	194	123	301	82	6.7

Dimensions based on configuration with PVC-U ball valve

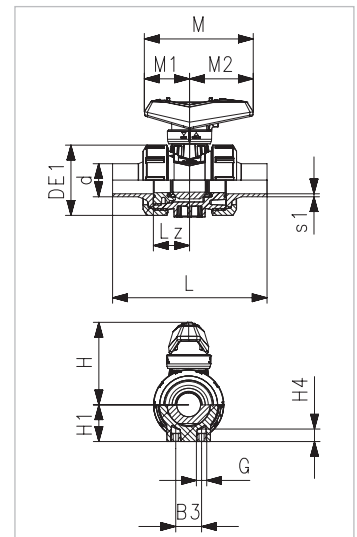

Ball Valve type 546 Pro with butt fusion spigots long, metric

d (mm)	DN (mm)	Size (inch)	DE1 (mm)	M (mm)	M1 (mm)	M2 (mm)	B3 (mm)	G (mm)	H4 (mm)	H (mm)	H1 (mm)	L (mm)	Lz (mm)	s1 (mm)
20	15	½	50	82	35	47	25	M6	12	60.5	27	193	28	1.9
25	20	¾	58	106	44	62	25	M6	12	74	30	216	33	2.3
32	25	1	68	106	44	62	25	M8	12	80	36	223	36	3
40	32	1 ¼	84	131	57	74	45	M8	15	95	44	249	43	3.7
50	40	1 ½	97	131	57	74	45	M8	15	101.5	51	271	45	4.6
63	50	2	124	152	66	86	45	M8	15	116.5	64	321	51	5.8
75	65	2 ½	166	270	64	205	70	M8	15	169	85	386	68	6.8
90	80	3	200	270	64	205	70	M8	15	180	105	421	71	8.2
110	100	4	238	326	71	205	120	M12	22	194	123	484	82	10.0

Dimensions based on configuration with PVC-U ball valve

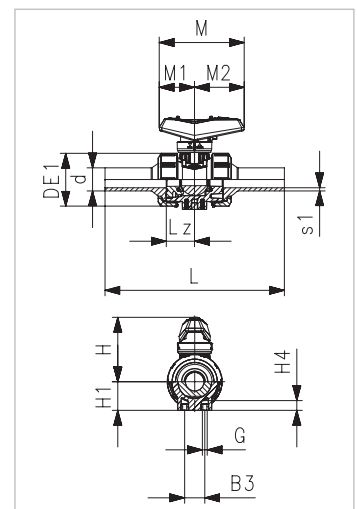

Ball Valve type 546 Pro with backing flanges, metric

d (mm)	DN (mm)	Size (inch)	DE1 (mm)	M (mm)	M1 (mm)	M2 (mm)	B3 (mm)	G (mm)	H4 (mm)	H (mm)	H1 (mm)	L (mm)	Lz (mm)	D1 (mm)	k1 (mm)
20	15	½	50	82	35	47	25	M6	12	60.5	27	130	28	95	56
25	20	¾	58	106	44	62	25	M6	12	74	30	150	33	105	75
32	25	1	68	106	44	62	25	M8	12	80	36	160	36	115	85
40	32	1 ¼	84	131	57	74	45	M8	15	95	44	180	43	140	100
50	40	1 ½	97	131	57	74	45	M8	15	101.5	51	200	45	150	110
63	50	2	124	152	66	86	45	M8	15	116.5	64	230	51	165	125
75	65	2 ½	166	270	64	205	70	M8	15	169	85	290	68	185	145
90	80	3	200	270	64	205	70	M8	15	180	105	310	71	200	160
110	100	4	238	326	71	255	120	M12	22	194	123	350	82	238	180

Dimensions based on configuration with PVC-U ball valve

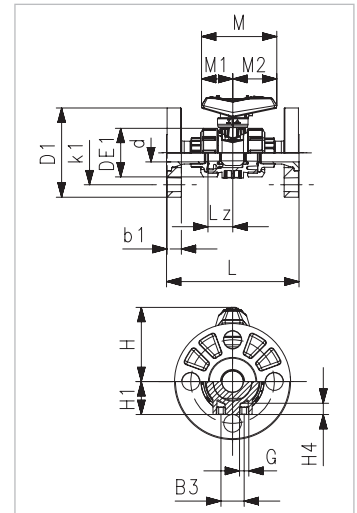

Ball Valve type 546 Pro with backing flanges, ANSI

d (mm)	DN (mm)	Size (inch)	DE1 (mm)	M (mm)	M1 (mm)	M2 (mm)	B3 (mm)	G (mm)	H4 (mm)	H (mm)	H1 (mm)	L (mm)	Lz (mm)	D1 (mm)	k1 (mm)
20	15	½	50	82	35	47	25	M6	12	60.5	27	130	28	95	60
25	20	¾	58	106	44	62	25	M6	12	74	30	150	33	105	70
32	25	1	68	106	44	62	25	M8	12	80	36	160	36	115	79
40	32	1 ¼	84	131	57	74	45	M8	15	95	44	180	43	140	89
50	40	1 ½	97	131	57	74	45	M8	15	101.5	51	200	45	150	98
63	50	2	124	152	66	86	45	M8	15	116.5	64	230	51	165	121
75	65	2 ½	166	270	64	205	70	M8	15	169	85	290	68	185	140
90	80	3	200	270	64	205	70	M8	15	180	105	310	71	200	152
110	100	4	238	326	71	255	120	M12	22	194	123	350	82	238	190

Dimensions based on configuration with PVC-U ball valve

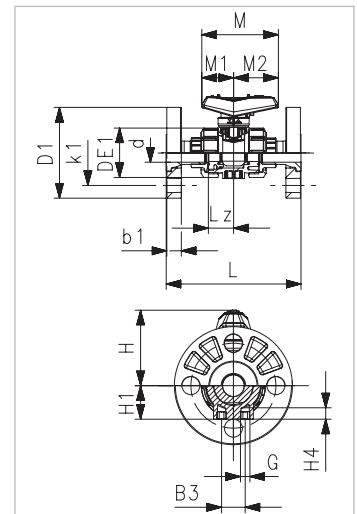

Ball Valve type 546 Pro with backing flanges, JIS

d (mm)	DN (mm)	Size (inch)	DE1 (mm)	M (mm)	M1 (mm)	M2 (mm)	B3 (mm)	G (mm)	H4 (mm)	H (mm)	H1 (mm)	L (mm)	Lz (mm)	D1 (mm)	k1 (mm)
20	15	½	50	82	35	47	25	M6	12	60.5	27	130	28	95	70
25	20	¾	58	106	44	62	25	M6	12	74	30	150	33	105	75
32	25	1	68	106	44	62	25	M8	12	80	36	160	36	115	90
40	32	1 ¼	84	131	57	74	45	M8	15	95	44	180	43	140	100
50	40	1 ½	97	131	57	74	45	M8	15	101.5	51	200	45	150	105
63	50	2	124	152	66	86	45	M8	15	116.5	64	230	51	165	120
75	65	2 ½	166	270	64	205	70	M8	15	169	85	290	68	185	140
90	80	3	200	270	64	205	70	M8	15	180	105	310	71	200	150
110	100	4	238	326	71	255	120	M12	22	194	123	350	82	238	175

Dimensions based on configuration with PVC-U ball valve

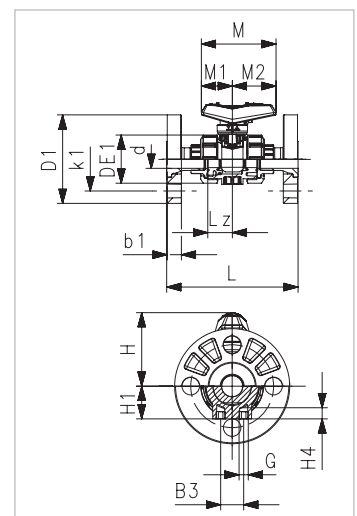

Ball Valve type 546 Pro with fixed flanges serrated, metric

d (mm)	DN (mm)	Size (inch)	DE1 (mm)	M (mm)	M1 (mm)	M2 (mm)	B3 (mm)	G (mm)	H4 (mm)	H (mm)	H1 (mm)	L (mm)	Lz (mm)	D1 (mm)	k1 (mm)
20	15	½	50	82	35	47	25	M6	12	60.5	27	130	28	95	56
25	20	¾	58	106	44	62	25	M6	12	74	30	150	33	105	75
32	25	1	68	106	44	62	25	M8	12	80	36	160	36	115	85
40	32	1 ¼	84	131	57	74	45	M8	15	95	44	180	43	140	100
50	40	1 ½	97	131	57	74	45	M8	15	101.5	51	200	45	150	110
63	50	2	124	152	66	86	45	M8	15	116.5	64	230	51	165	125
75	65	2 ½	166	270	64	205	70	M8	15	169	85	290	68	185	145
90	80	3	200	270	64	205	70	M8	15	180	105	310	71	200	160
110	100	4	238	326	71	255	120	M12	22	194	123	350	82	238	180

Dimensions based on configuration with PVC-U ball valve

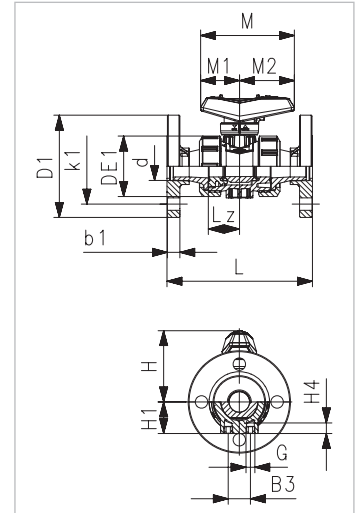

Ball Valve type 546 Pro with fixed flanges serrated, ANSI

d (mm)	DN (mm)	Size (inch)	DE1 (mm)	M (mm)	M1 (mm)	M2 (mm)	B3 (mm)	G (mm)	H4 (mm)	H (mm)	H1 (mm)	L (mm)	Lz (mm)	D1 (mm)	k1 (mm)
20	15	½	50	82	35	47	25	M6	12	60.5	27	130	28	95	60
25	20	¾	58	106	44	62	25	M6	12	74	30	150	33	105	70
32	25	1	68	106	44	62	25	M8	12	80	36	160	36	115	79
40	32	1 ¼	84	131	57	74	45	M8	15	95	44	180	43	140	89
50	40	1 ½	97	131	57	74	45	M8	15	101.5	51	200	45	150	98
63	50	2	124	152	66	86	45	M8	15	116.5	64	230	51	165	121
75	65	2 ½	166	270	64	205	70	M8	15	169	85	290	68	185	140
90	80	3	200	270	64	205	70	M8	15	180	105	310	71	200	152
110	100	4	238	326	71	255	120	M12	22	194	123	350	82	238	190

Dimensions based on configuration with PVC-U ball valve

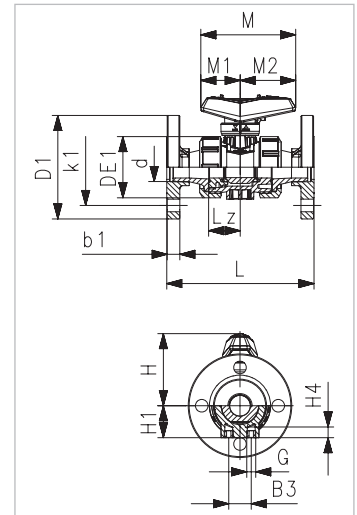

Ball Valve type 546 Pro with fixed flanges serrated, JIS

d (mm)	DN (mm)	Size (inch)	DE1 (mm)	M (mm)	M1 (mm)	M2 (mm)	B3 (mm)	G (mm)	H4 (mm)	H (mm)	H1 (mm)	L (mm)	Lz (mm)	D1 (mm)	k1 (mm)
20	15	½	50	82	35	47	25	M6	12	60.5	27	130	28	95	70
25	20	¾	58	106	44	62	25	M6	12	74	30	150	33	105	75
32	25	1	68	106	44	62	25	M8	12	80	36	160	36	115	90
40	32	1 ¼	84	131	57	74	45	M8	15	95	44	180	43	140	100
50	40	1 ½	97	131	57	74	45	M8	15	101.5	51	200	45	150	105
63	50	2	124	152	66	86	45	M8	15	116.5	64	230	51	165	120
75	65	2 ½	166	270	64	205	70	M8	15	169	85	290	68	185	140
90	80	3	200	270	64	205	70	M8	15	180	105	310	71	200	150
110	100	4	238	326	71	255	120	M12	22	194	123	350	82	238	175

Dimensions based on configuration with PVC-U ball valve

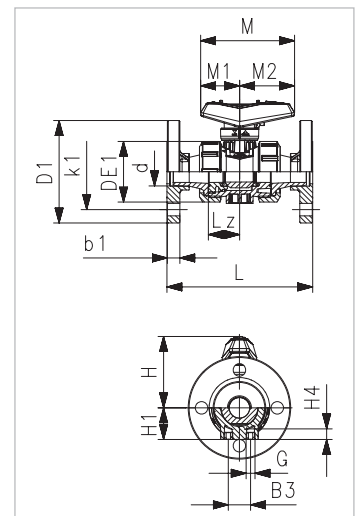

Accessories

Double sensor for electrical position feedback

After being mounted in the valve or in the interface module, the double sensor is used to signal the CLOSED or OPEN position of the valve via an electric signal to a controller, supplied by the customer. The switching states are also output optically via two integrated LEDs.

LED signal color	Function	Code
Closed: Green / Open: Red	PNP	198546001
Closed: Red / Open: Green	PNP	198546002
Closed: Green / Open: Red	NPN	198546005
Closed: Red / Open: Green	NPN	198546006
Closed: Green / Open: Red	NAMUR	198546003
Closed: Red / Open: Green	NAMUR	198546004



Suitable connection cables available as accessories

Spring reset unit, manual actuation (dead man's switch)

The spring reset unit (dead man's switch) is installed onto the ball valve type 546 Pro or type 543 Pro and ensures that the ball valve is closed automatically as soon as the handle is released. It is opened against the spring force.

DN (mm)	Code
DN10/15	198546082
DN20/25	198546083



Interface module, manual actuated

With the manually actuated interface module the open or closed position of the ball valve type 546 Pro or type 543 Pro can be transmitted via an electric signal to a customer control.

DN (mm)	Code	DN10-50	DN65-100
DN10/15	198546102		
DN20/25	198546103		
DN32/40	198546105		
DN50	198546107		
DN65/80	198546108		
DN100	198546109		

Interface module, automatic actuated

With the help of the automatically actuated interface module, electric or pneumatic actuators can be attached on the ball valve type 546 Pro or type 543 Pro, which allows the automation of the ball valve's change of position. In addition, an interface is available for the installation of an electrical position feedback indicator.

DN (mm)	Code Pneumatic GF actuators s PPA	Code Electric GF actuators EA/dEA
DN10/15	198546162	198546142
DN20	198546163	198546143
DN25	198546164	198546144
DN32	198546135	198546145
DN40	198546136	198546146
DN50	198546137	198546147
DN65/80	PPA40 198546165 PPA80 198546166	198546148
DN100	198546167	198546149

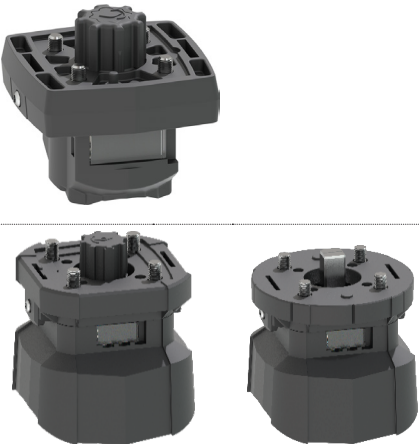

DN (mm)	SW	Code Norm actuators according to ISO 5211	DN10-50	DN65-100
DN10/15	SW09	198546122		
DN10/15	SW11/14	198546123		
DN20/25	SW09	198546124		
DN20/25	SW11/14	198546125		
DN32-40	SW11/14	198546126		
DN50	SW11/14	198546127		
DN65/80	SW11	198546128		
DN100	SW14	198546129		



Transparent lever clip

Type 546 Pro or type 543 Pro ball valves can be quickly and easily labelled with the most important information. Operation and maintenance can thus be made safer, faster and clearer. In addition, there are various standards which prescribe a clear marking of the pipeline.

DN (mm)	Pcs.	Code
DN10/15	10 Stk.	198807221
DN20/25	10 Stk.	198807222
DN32/40	5 Stk.	198807223
DN50	5 Stk.	198807224
DN65/80	5 Stk.	198807225
DN100	5 Stk.	198807226



Printed sheets for ball valve lever

Dimension	Code	Quantity	Picture
DN10/15	198 807 231	25 sheets with 48 labels each	
DN10/15	198 807 241	100 sheets with 48 labels each	
DN20/25	198 807 232	25 sheets with 24 labels each	
DN20/25	198 807 242	100 sheets with 24 labels each	
DN32/40	198 807 233	25 sheets with 18 labels each	
DN32/40	198 807 243	100 sheets with 18 labels each	
DN50	198 807 234	25 sheets with 11 labels each	
DN50	198 807 244	100 sheets with 11 labels each	
DN65/80	198 807 235	25 sheets with 6 labels each	
DN100	198 807 236	25 sheets with 4 labels each	

Printed sheets for interface modules

The transparent labeling clips are supplied with the interface modules.

The labeling can be used with hand operated valves with a manual interface as well as with automatically powered ball valves.

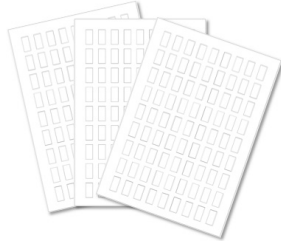
Dimension	Code	Quantity	Picture
DN10 - DN100	198 807 230	25 sheets with 81 labels each	

Further accessories

- Hand lever extension
- Adapter for padlocks
- Tool for disassembling interface modules
- Additional limit switches



For further information on accessories, refer to the online product catalogue at www.gfps.com

- Mobile apps and online tools to support configuration and calculation at www.gfps.com/tools



Ball Valve type 546 Pro, electric actuated (Type 127, 179–184)



Type 127
With electric actuator EA15

Type 179 – 184
With electric actuators EA and dEA

Product description

Type 127

The type 127 is designed for automated standard applications with no special demands. The Ball Valve type is based on the Ball Valve type 546 Pro and the electric actuator EA15.

Type 179 – 184

The 179 – 184 series is designed as modular adjustable ball valves for applications which demand special process requirements. Ball valves are based on the Ball Valve type 546 Pro and the electric actuators EA or the smart electric actuator dEA.

Applications

- Chemical process industry
- Water treatment
- Microelectronics
- Measurement and control
- Ship building
- Food & beverage

Benefits/features

Type 127

- Electrical feedback with additional limit switches of different designs integrated into the actuator or interface module
- Integrated emergency manual override
- Optional: Fail-safe return unit with or without integrated battery pack

Type 179 – 184

- Electrical feedback with additional limit switches of different designs integrated into the actuator or in the interface module (optional 4-20 mA with Positioner)
- Rotation angle up to 355°; Preset to 0°-90°
- Up to 3 freely selectable stop positions (open/middle/close)
- Integrated emergency manual override
- Optional: Fail-safe return unit with or without integrated battery pack
- Optional: Cycle time monitoring
- Optional: Cycle counter
- Optional: Cycle time extension
- Optional: Motor current monitoring
- Optional: Positioner

Flow media

Neutral and aggressive media with a small amount of particles/solids. The chemical resistance is independent of the selected valve material ([see online tool ChemRes PLUS](#)).

Technical Data

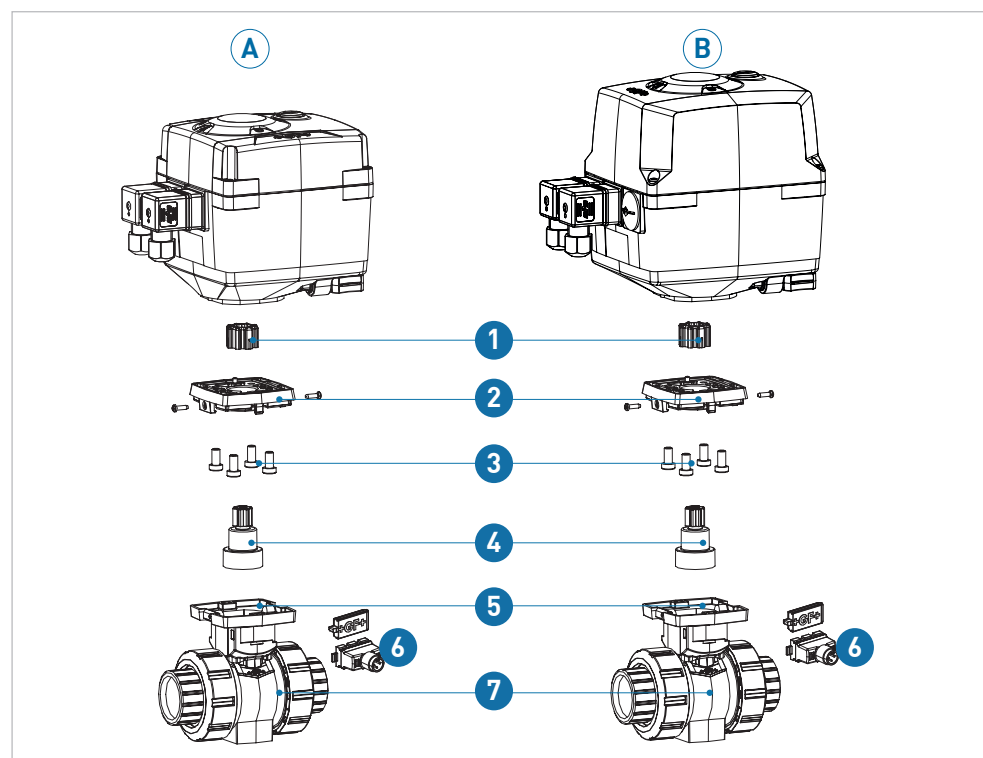

- A Actuator Type EA15
- B Actuator Type EA25/EA45/EA120
- 1 Adapter
- 2 Adapter plate
- 3 PT screws
- 4 Coupling piece
- 5 Interface housing
- 6 Labelling clip or double sensor for electrical position feedback (custom versions only)
- 7 Ball Valve Type 546 Pro

Specification			
Dimensions	Type 127	EA15	d16/DN10 – d63/DN50
	Type 179-184	EA25	d16/DN10 – d63/DN50
		EA45	d75/DN65
		EA120	d90/DN80 – d110/DN100
Base type	Type 546 Pro		
Materials	Type 127, 179-184	PVC-U, PVC-C, ABS, PP-H, PVDF	
Seal materials		EPDM, FKM, FFKM, NBR	
Pressure levels		PN10	
Connections		Socket, spigot, flanges, threaded socket	
Connection standards	ISO, BS, ASTM, JIS		

i The following technical data can be found in the Planning Fundamentals under "Ball Valve type 546 Pro, manually operated":

- Pressure-temperature diagram
- Pressure loss
- Flow characteristics
- Kv values
- Reference values for fastening screws

Technical basics

Differences between types 127 and 179 – 184

	Type 127	Type 179	Type 180	Type 181	Type 182	Type 183	Type 184
PVC-U	x	x			x	x	x
PVC-C	x	x			x		x
ABS	x	x				x	
PP-H	x		x				x
PVDF				x			x
ISO	x	x	x	x			
ASTM	x		x	x	x		
BS	x					x	
JIS	x						x

- The actuators are manufactured according to the specification of EN 61010-1, EC 89/336/EEC-EMV 73/23/EEC, LVD.
- All actuators have the CE marking.
- The actuator housings are made of PPGF (fiberglass-reinforced polypropylene) and external, stainless steel screws with low flammability.
- All electric actuators have an emergency manual override and an optical position indicator.

Properties of electric actuators

Actuator	Cycle time	Nominal torque	Actuating cycles at 20 °C	Duty cycle at 25 °C/15min
EA15	5s/90°	10Nm	150 000	40%
EA25 / dEA25	5s/90°	10 Nm	250 000	100%
EA45 / dEA45	6s /90°	20 Nm	100 000	50%
EA120 / dEA120	15s/90°	60 Nm	100 000	50%
EA250 / dEA250	20s/90°	100 Nm	75 000	35%

i All electric actuators have an IP67 rating in accordance with EN 60529 (with vertical installation and appropriate cable connection).

Valve handling

Installation notes

During installation, ensure that the actuator is correctly built onto and connected to the correct valve. In order to guarantee control provided on the customer side, the following points must be observed:

- Actuate valves with 90° rotary movement.
- Indicate the previously calibrated end positions of the valve via an electrical signal to the aforementioned system control.
- If the supply voltage fails, the actuator should remain in its current position. For this purpose, the installation of the manual override or the position reset unit is recommended (see accessories).

In case of interruption in the supply voltage, ensure that the actuator remains in the current position. For this, installation of an emergency manual override or reset unit is recommended (refer to "Accessories").

Maintenance notes

Set maintenance intervals as per the conditions of use (e.g., actuating cycles, medium, ambient temperature). As part of the regular system inspection, carry out the following maintenance activities:

- Regularly check that no medium escapes to the outside.
- We recommend a function test for ball type valves that are kept permanently in the same position 1 – 2 times per year to check functionality.
- Check that cover of the emergency manual override is correctly fitted. If necessary, fit cover.
- Check that housing cover of the actuator is fitted with 4 screws. Insert screws if necessary.
- Check if grating noises are coming from the actuator. Replace actuator, see assembly instructions for building valve with actuator.
- Check that position display matches signal of the control. If necessary, adjust limit switches.

For frequent control operations or due to chemical attack on the sealing material, it may become necessary to replace parts inside the valve.



Installation and maintenance must be performed according to the corresponding installation instructions. The installation manual is included with the product, see also the online product catalog at www.gfps.com

Dimensions

Type 127 (EA15), solvent cement sockets

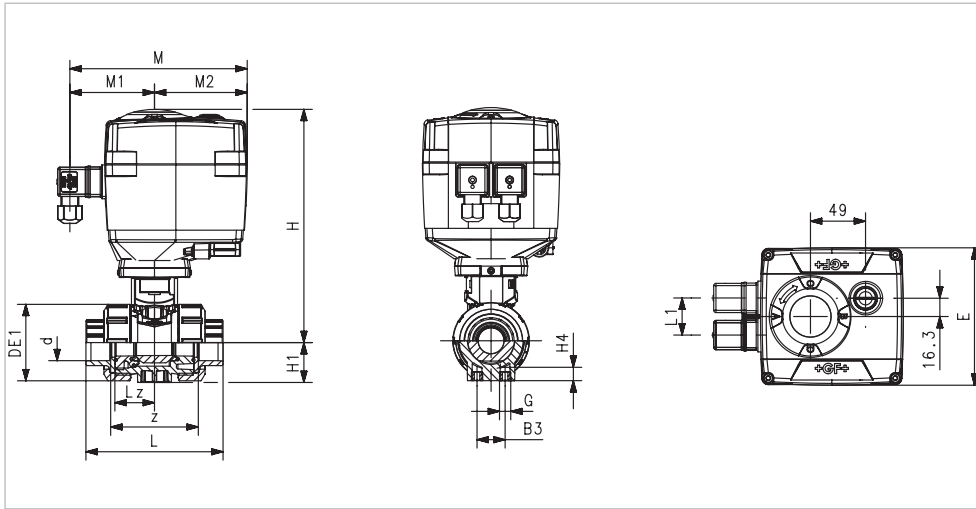

d (mm)	DN (mm)	Size (inch)	Actuator	B3 (mm)	DE1 (mm)	E (mm)	G (mm)	H (mm)	H1 (mm)	H4 (mm)
16	10	3/8	EA15	25	50	122	M6	197	27	12
20	15	1/2	EA15	25	50	122	M6	197	27	12
25	20	3/4	EA15	25	58	122	M6	201	30	12
32	25	1	EA15	25	68	122	M8	207	36	12
40	32	1 1/4	EA15	45	84	122	M8	213	44	15
50	40	1 1/2	EA15	45	97	122	M8	219	51	15
63	50	2	EA15	45	124	122	M8	234	64	15

d (mm)	DN (mm)	Size (inch)	L (mm)	L1 (mm)	Lz (mm)	M (mm)	M1 (mm)	M2 (mm)	z (mm)
16	10	3/8	92	33	28	161	77	83	64
20	15	1/2	95	33	28	161	77	83	64
25	20	3/4	110	33	33	161	77	83	72
32	25	1	123	33	36	161	77	83	79
40	32	1 1/4	146	33	43	161	77	83	94
50	40	1 1/2	157	33	45	161	77	83	95
63	50	2	183	33	51	161	77	83	107

Dimensions based on configuration with PVC-U ball valve, metric

Type 127 (EA15), solvent cement spigots

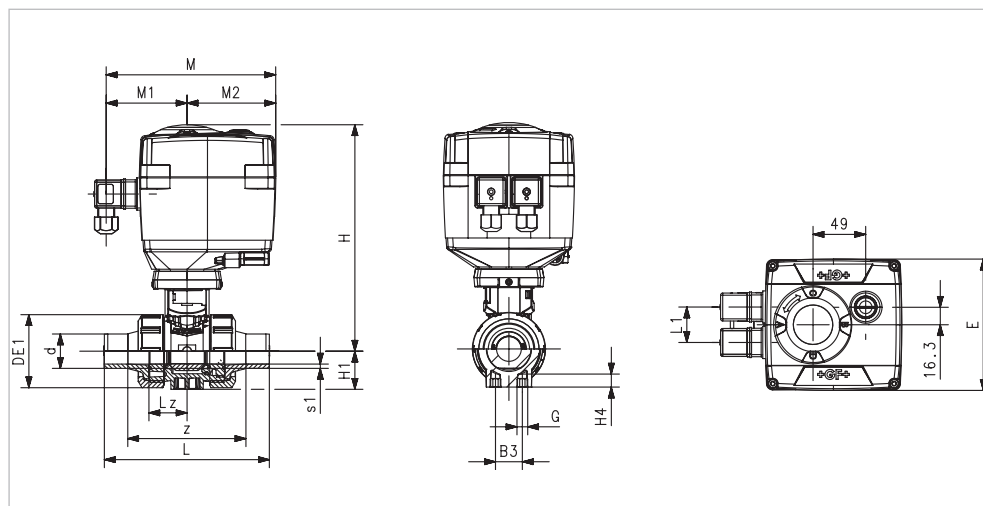

d (mm)	DN (mm)	Size (inch)	Actuator	B3 (mm)	DE1 (mm)	E (mm)	G (mm)	H (mm)	H1 (mm)	H4 (mm)
16	10	3/8	EA15	25	50	122	M6	197	27	12
20	15	1/2	EA15	25	50	122	M6	197	27	12
25	20	3/4	EA15	25	58	122	M6	201	30	12
32	25	1	EA15	25	68	122	M8	207	36	12
40	32	1 1/4	EA15	45	84	122	M8	213	44	15
50	40	1 1/2	EA15	45	97	122	M8	219	51	15
63	50	2	EA15	45	124	122	M8	234	64	15

d (mm)	DN (mm)	Size (inch)	L (mm)	L1 (mm)	Lz (mm)	M (mm)	M1 (mm)	M2 (mm)	z (mm)	s1 (mm)
16	10	3/8	114	33	28	161	77	83	88	3.0
20	15	1/2	124	33	28	161	77	83	96	3.0
25	20	3/4	144	33	33	161	77	83	112	3.0
32	25	1	154	33	36	161	77	83	118	4.0
40	32	1 1/4	174	33	43	161	77	83	134	4.5
50	40	1 1/2	194	33	45	161	77	83	148	5.5
63	50	2	224	33	51	161	77	83	170	7.0

Dimensions based on configuration with PP-H ball valve, metric

Type 127 (EA15), threaded sockets, Rp

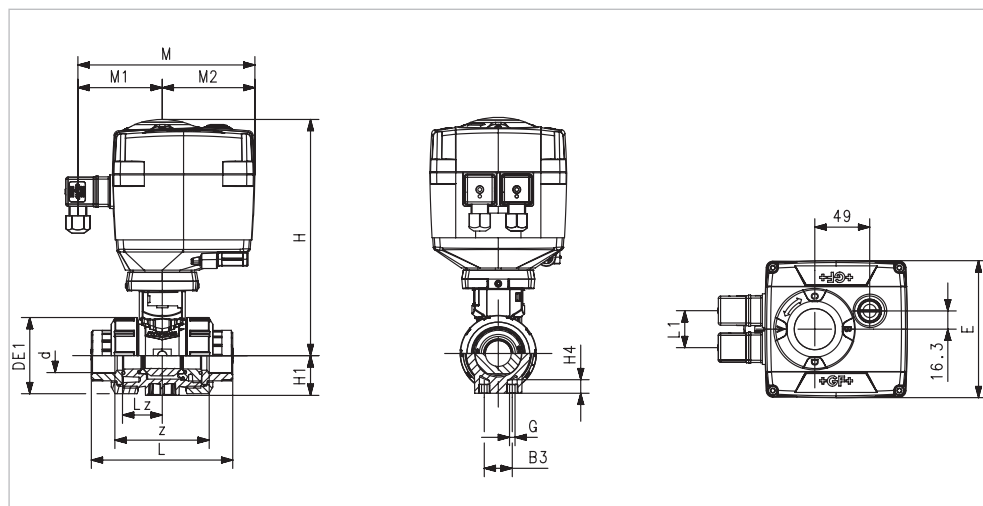

d (mm)	DN (mm)	Size (inch)	Actuator	B3 (mm)	DE1 (mm)	E (mm)	G (mm)	H (mm)	H1 (mm)	H4 (mm)
16	10	3/8	EA15	25	50	122	M6	197	27	12
20	15	1/2	EA15	25	50	122	M6	197	27	12
25	20	3/4	EA15	25	58	122	M6	201	30	12
32	25	1	EA15	25	68	122	M6	207	36	12
40	32	1 1/4	EA15	45	84	122	M8	213	44	15
50	40	1 1/2	EA15	45	97	122	M8	219	51	15
63	50	2	EA15	45	124	122	M8	234	64	15

d (mm)	DN (mm)	Size (inch)	L (mm)	L1 (mm)	Lz (mm)	M (mm)	M1 (mm)	M2 (mm)	z (mm)
16	10	3/8	95	33	28	161	77	83	88
20	15	1/2	100	33	28	161	77	83	96
25	20	3/4	114	33	33	161	77	83	112
32	25	1	127	33	36	161	77	83	118
40	32	1 1/4	146	33	43	161	77	83	134
50	40	1 1/2	152	33	45	161	77	83	148
63	50	2	177	33	51	161	77	83	170

Dimensions based on configuration with PVC-U ball valve, Rp

Type 127 (EA15), fixed flanges

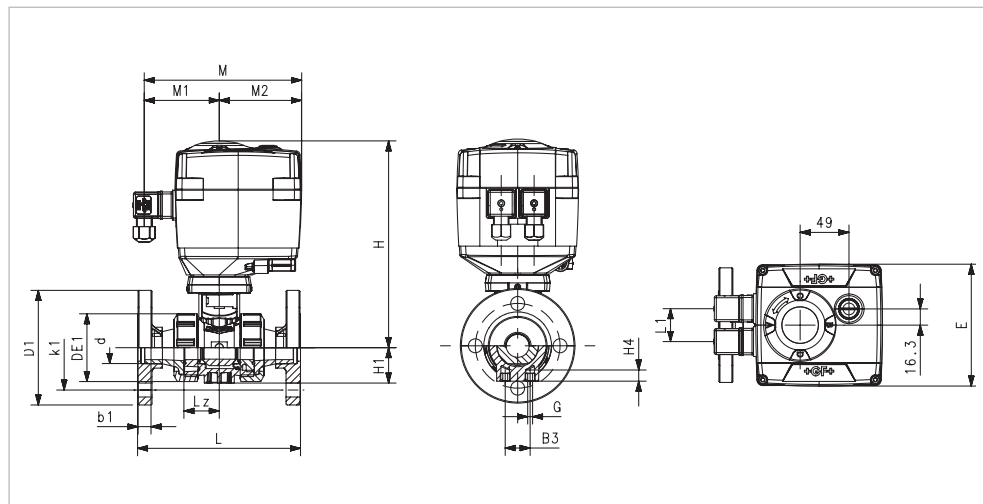

d (mm)	DN (mm)	Size (inch)	Actuator	B3 (mm)	DE1 (mm)	E (mm)	G (mm)	H (mm)	H1 (mm)	H4 (mm)
20	15	½	EA15	25	50	122	M6	197	27	12
25	20	¾	EA15	25	58	122	M6	201	30	12
32	25	1	EA15	25	68	122	M6	207	36	12
40	32	1 ¼	EA15	45	84	122	M8	213	44	15
50	40	1 ½	EA15	45	97	122	M8	219	51	15
63	50	2	EA15	45	124	122	M8	234	64	15

d (mm)	DN (mm)	Size (inch)	L (mm)	L1 (mm)	Lz (mm)	M (mm)	M1 (mm)	M2 (mm)	b1 (mm)	D1 (mm)	k1 (mm)
20	15	½	100	33	28	161	77	83	12	95	56
25	20	¾	114	33	33	161	77	83	12	105	75
32	25	1	127	33	36	161	77	83	14	115	85
40	32	1 ¼	146	33	43	161	77	83	16	140	100
50	40	1 ½	152	33	45	161	77	83	16	150	110
63	50	2	177	33	51	161	77	83	18	165	125

Dimensions based on configuration with PVC-U ball valve, metric

Type 127 (EA15), backing flanges

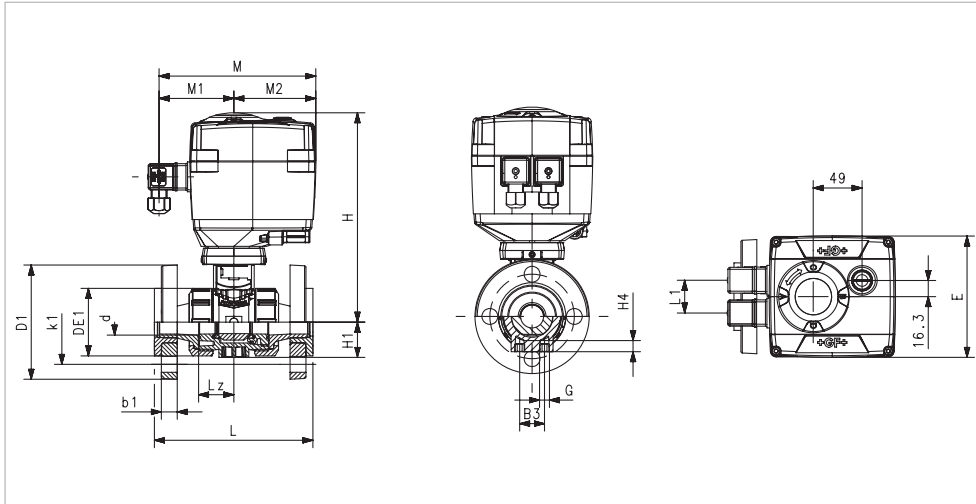

d (mm)	DN (mm)	Size (inch)	Actuator	B3 (mm)	DE1 (mm)	E (mm)	G (mm)	H (mm)	H1 (mm)	H4 (mm)
20	15	½	EA15	25	50	122	M6	197	27	12
25	20	¾	EA15	25	58	122	M6	201	30	12
32	25	1	EA15	25	68	122	M6	207	36	12
40	32	1 ¼	EA15	45	84	122	M8	213	44	15
50	40	1 ½	EA15	45	97	122	M8	219	51	15
63	50	2	EA15	45	124	122	M8	234	64	15

d (mm)	DN (mm)	Size (inch)	L (mm)	L1 (mm)	Lz (mm)	M (mm)	M1 (mm)	M2 (mm)	b1 (mm)	D1 (mm)	k1 (mm)
20	15	½	130	33	28	161	77	83	12	95	60
25	20	¾	150	33	33	161	77	83	12	105	70
32	25	1	160	33	36	161	77	83	14	115	79
40	32	1 ¼	180	33	43	161	77	83	16	140	89
50	40	1 ½	200	33	45	161	77	83	16	150	98
63	50	2	230	33	51	161	77	83	18	165	121

Dimensions based on configuration with PVC-U ball valve, metric

Type 179 – 184 (EA25-250), solvent cement sockets

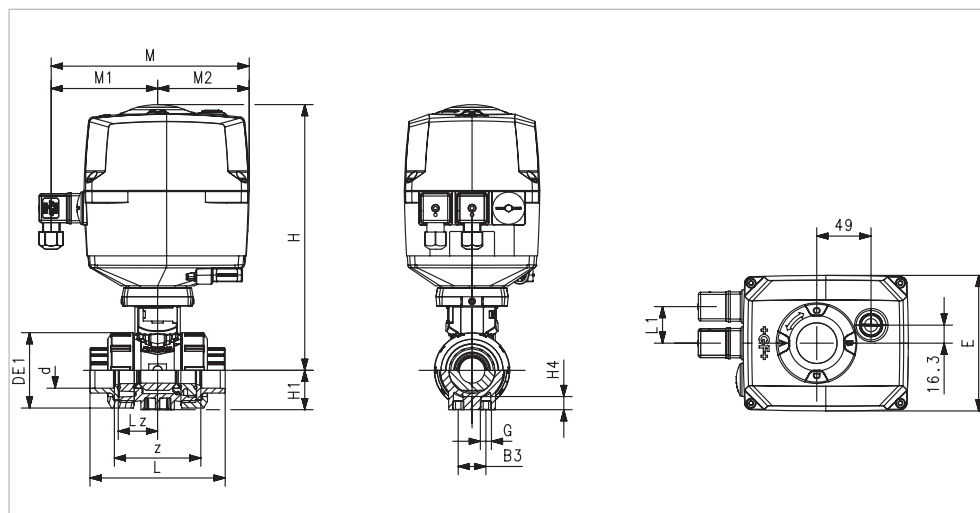

d (mm)	DN (mm)	Size (inch)	Actuator	B3 (mm)	DE1 (mm)	E (mm)	G (mm)	H (mm)	H1 (mm)	H4 (mm)
16	10	3/8	EA25	25	50	122	M6	227	27	12
20	15	1/2	EA25	25	50	122	M6	227	27	12
25	20	3/4	EA25	25	58	122	M6	231	30	12
32	25	1	EA25	25	68	122	M8	237	36	12
40	32	1 1/4	EA25	45	84	122	M8	243	44	15
50	40	1 1/2	EA25	45	97	122	M8	249	51	15
63	50	2	EA25	45	124	122	M8	264	64	15
75	65	2 1/2	EA45	70	166	122	M8	313	85	15
90	80	3	EA45	70	200	122	M8	325	105	15
110	100	4	EA120	120	128	122	M12	363	123	22

d (mm)	DN (mm)	Size (inch)	L (mm)	L1 (mm)	Lz (mm)	M (mm)	M1 (mm)	M2 (mm)	z (mm)
16	10	3/8	92	33	28	180	97	83	64
20	15	1/2	95	33	28	180	97	83	64
25	20	3/4	110	33	33	180	97	83	72
32	25	1	123	33	36	180	97	83	79
40	32	1 1/4	146	33	43	180	97	83	94
50	40	1 1/2	157	33	45	180	97	83	95
63	50	2	183	33	51	180	97	83	107
75	65	2 1/2	233	33	68	180	98	83	144
90	80	3	254	33	71	180	98	83	151
110	100	4	301	33	82	180	98	83	174

Dimensions based on configuration with PVC-U ball valve, metric

Type 179 – 184 (EA25-250), fusion spigots

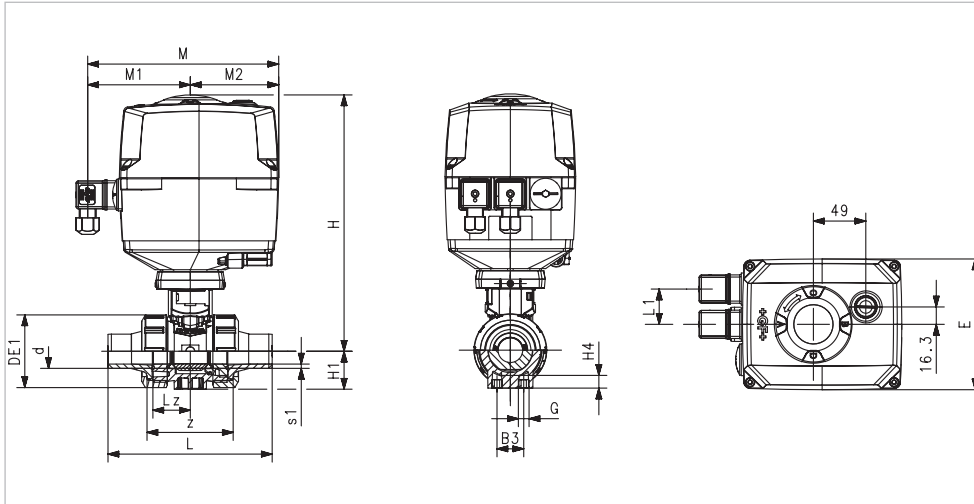

d (mm)	DN (mm)	Size (inch)	Actuator	B3 (mm)	DE1 (mm)	E (mm)	G (mm)	H (mm)	H1 (mm)	H4 (mm)
20	15	½	EA25	25	50	122	M6	227	27	12
25	20	¾	EA25	25	58	122	M6	231	30	12
32	25	1	EA25	25	68	122	M8	237	36	12
40	32	1 ¼	EA25	45	84	122	M8	243	44	15
50	40	1 ½	EA25	45	97	122	M8	249	51	15
63	50	2	EA25	45	124	122	M8	264	64	15
75	65	2 ½	EA45	70	166	122	M8	313	85	15
90	80	3	EA45	70	200	122	M8	325	105	15
110	100	4	EA120	120	238	122	M12	363	123	22

d (mm)	DN (mm)	Size (inch)	L (mm)	L1 (mm)	Lz (mm)	M (mm)	M1 (mm)	M2 (mm)	z (mm)	s1 (mm)
20	15	½	130	33	28	180	97	83	92	1.9
25	20	¾	143	33	33	180	97	83	107	2.3
32	25	1	150	33	36	180	97	83	114	3
40	32	1 ¼	171	33	43	180	97	83	130	3.7
50	40	1 ½	191	33	45	180	97	83	144	4.6
63	50	2	220	33	51	180	97	83	166	5.8
75	65	2 ½	266	33	68	180	98	83	190	8.2
90	80	3	264	33	71	180	98	83	192	10
110	100	4	301	33	82	180	98	83	208	12

Dimensions based on configuration with PP-H ball valve, metric

Type 179 – 184 (EA25-250), fixed flanges

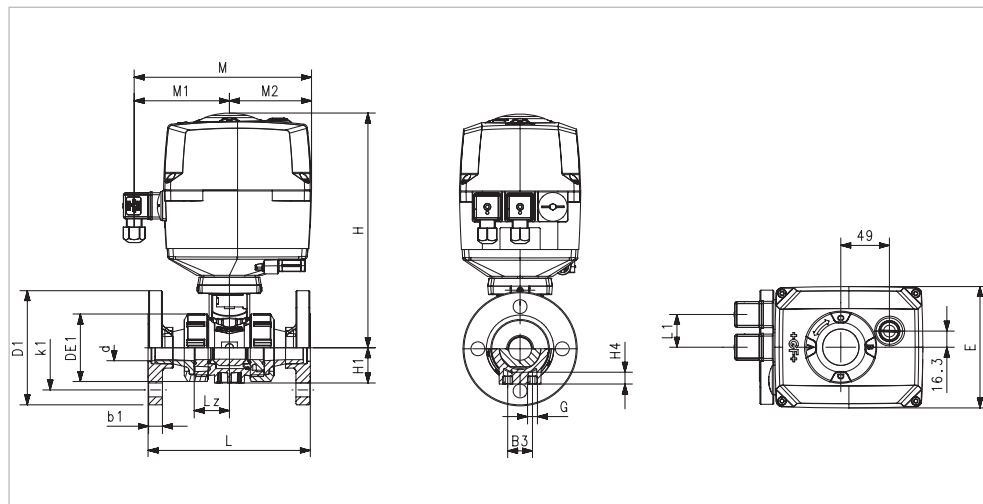

d (mm)	DN (mm)	Size (inch)	Actuator	B3 (mm)	DE1 (mm)	E (mm)	G (mm)	H (mm)	H1 (mm)	H4 (mm)
20	15	½	EA25	25	50	122	M6	227	27	12
25	20	¾	EA25	25	58	122	M6	231	30	12
32	25	1	EA25	25	68	122	M6	237	36	12
40	32	1 ¼	EA25	45	84	122	M8	243	44	15
50	40	1 ½	EA25	45	97	122	M8	249	51	15
63	50	2	EA25	45	124	122	M8	264	64	15

d (mm)	DN (mm)	Size (inch)	L (mm)	L1 (mm)	Lz (mm)	M (mm)	M1 (mm)	M2 (mm)	b1 (mm)	D1 (mm)	k1 (mm)
20	15	½	130	33	28	180	97	83	12	95	70
25	20	¾	150	33	33	180	97	83	12	105	75
32	25	1	160	33	36	180	97	83	14	115	90
40	32	1 ¼	180	33	43	180	97	83	16	140	100
50	40	1 ½	200	33	45	180	97	83	16	150	105
63	50	2	230	33	51	180	97	83	18	165	120

Dimensions based on configuration with PVC-U ball valve, metric

Type 179 – 184 (EA25-250), backing flanges

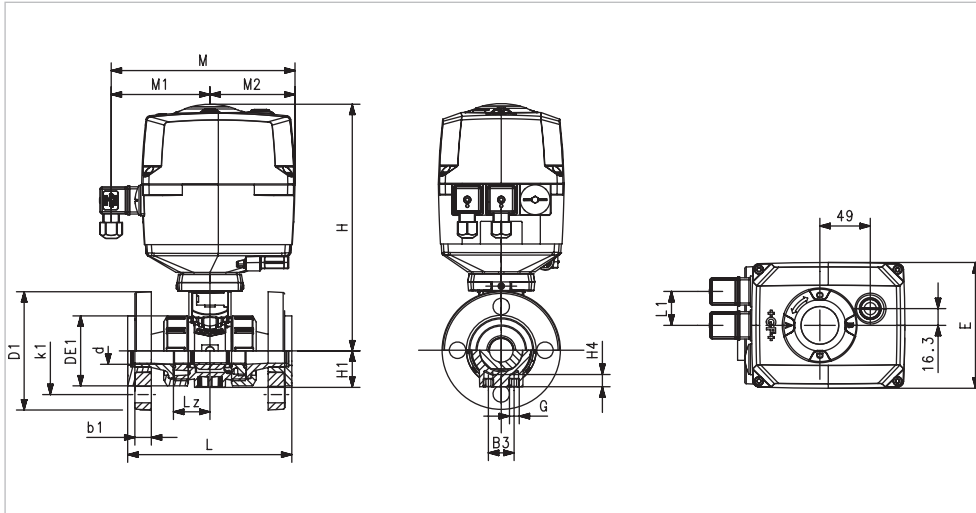

d (mm)	DN (mm)	Size (inch)	Actuator	B3 (mm)	DE1 (mm)	E (mm)	G (mm)	H (mm)	H1 (mm)	H4 (mm)
75	65	2 ½	EA45	70	166	122	M8	313	85	15
90	80	3	EA45	70	200	122	M8	325	105	15
110	100	4	EA120	120	238	122	M12	363	123	22

d (mm)	DN (mm)	Size (inch)	L (mm)	L1 (mm)	Lz (mm)	M (mm)	M1 (mm)	M2 (mm)	b1 (mm)	k1 (mm)
75	65	2 ½	290	33	68	180	98	82	18	140
90	80	3	310	33	71	180	98	82	20	150
110	100	4	350	33	82	180	98	82	20	175

Dimensions based on configuration with PVC-U ball valve

Accessories

EA15 / EA25 / EA45 / EA120 / EA250:

- Fail-safe return unit with or without integrated battery package
- AS-interface plug on module
- Limit switch assembly kits for multi function module AgNi, Au, NPN, PNP

EA25 / EA45 / EA120 / EA250:

- Monitoring board with cycle time extension, cycle time monitoring, cycle cycle time monitoring, cycle counter and motor current monitoring
- Positioner board for modulating operation with 4-20 mA Feedback and integrated motor current monitoring
- Profibus DP V0 plug-on module



For further information on accessories, refer to the online product catalog at www.gfps.com

Ball Valve type 546 Pro, electric actuated (Type 104)



Type 104

With electric actuator EA04

Product description

Available in PVC-U, PVC-C and PP-H, the Ball Valve type 104 from GF Piping Systems is an efficient solution for less demanding applications. type 104 is based on the same industrial ball type valve that GF Piping Systems utilizes in other applications. This means that the valve can be removed and serviced. With a duty cycle of 75 %, the valve is suited for a low to median number of actuations.

Applications

- Chemical process industry
- Microelectronics
- Measurement and control
- Shipbuilding
- Food & beverage

Benefits/features

- Optical position indicator
- Integrated emergency manual override
- Multi-colour led status light as standard
- Integrated mounting inserts for attaching the valve
- All actuators have the CE marking.

Flow media

Neutral and aggressive media with a small amount of particles/solids. The chemical resistance depends on the selected valve material ([see online tool ChemRes PLUS](#)).

Technical data

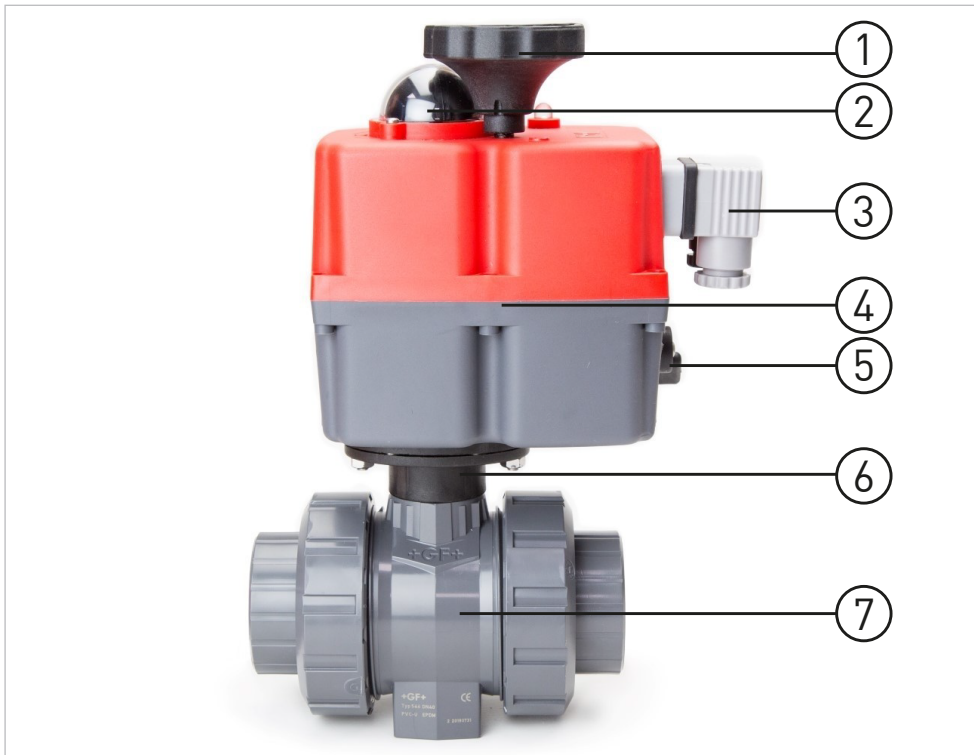

- 1 Emergency manual override
- 2 Position indicator
- 3 Connection for control voltage/feedback
- 4 Electric actuator EA04
- 5 Switch emergency manual override
- 6 Assembly kit
- 7 Ball Valve Type 546 Pro

Specification

Dimensions	Type 104	EA04	d16/DN10 – d63/DN50
Ball valve	Type 546 Pro		
Materials	PVC-U, PVC-C, PP-H		
Gasket materials	EPDM, FKM		
Pressure rating	PN10		
Connections	Socket, Spigot, NPT thread		
Nominal torque	20Nm		
Voltage	85 - 240 V AC/DC		
Standards	ISO, BS, ASTM, JIS		



The following technical data can be found in the Planning Fundamentals under "Ball Valve type 546 Pro, manually operated":

- Pressure-temperature diagram
- Pressure loss
- Flow characteristics
- Kv values
- Reference values for screw fastenings

Technical basics

Valve handling

Installation notes

During installation, ensure that the actuator is correctly built onto and connected to the correct valve.

The following points must be observed:

- Actuate valves with 90° rotary movement
- Indicate the previously calibrated end positions of the valve via electrical signal to the aforementioned system control
- In case of interruption in the power supply, ensure that the actuator remains in the current position. For this, installation of an emergency manual override or reset unit is recommended

Maintenance notes

Set maintenance intervals as per the conditions of use (e. g. actuating cycles, medium, ambient temperature). As part of the regular system inspection, carry out the following maintenance activities:

- Regularly check that no medium escapes to the outside
- We recommend a function test for ball valves that are kept permanently in the same position 1 – 2 times per year to check functionality
- Check that cover of the emergency manual override is correctly fitted. If necessary, fit cover
- Check that housing cover of the actuator is fitted with all screws. Insert screws if necessary
- Check if grating noises are coming from the actuator. Replace actuator, see assembly instructions for installing ball valve with electric actuator
- Check that position display matches signal from the controller
- If necessary, adjust limit switches

For frequent control operations or due to chemical attack on the sealing material, it may become necessary to replace parts inside the valve.



Installation and maintenance must be performed according to the corresponding installation instructions. The installation manual is included with the product, see also the online product catalog at www.gfps.com

Ball Valve type 546 Pro P, pneumatic actuated

		
<p>Type 546 Pro P, DN10-DN50 with pneumatic actuator PA08-40, without manual override</p>	<p>Type 546 Pro P, DN10-DN50 with pneumatic actuator PPA08-40, with manual override</p>	<p>Type 546 Pro P, DN65-DN100 with pneumatic actuator PA80, without manual override</p>

Product description

The pneumatic actuated ball valve series is modularly configurable and designed for applications that require special process requirements. It is based on the ball valve 546 Pro and the pneumatic actuators PPA08, PPA15, PPA40 and PPA80.

Applications

- Chemical process industry
- Water treatment
- Microelectronics
- Measurement and control
- Shipbuilding
- Cooling

Benefits/features

- Electrical position feedback at the stem of the valve (via optional PNP or NPN double sensor)
- Full plastic solution (housing of PPA actuator made of PP-GF)
- Long service life with more than 50,000 cycles
- Pressure control connection based on NAMUR standard
- Optional with emergency manual override
- Compact design
- Optional positioner and solenoid valve

Flow media

Neutral and aggressive media with a small amount of particles/solids. The chemical resistance is dependent on the selected valve material ([see online tool ChemRes PLUS](#)).

Technical data

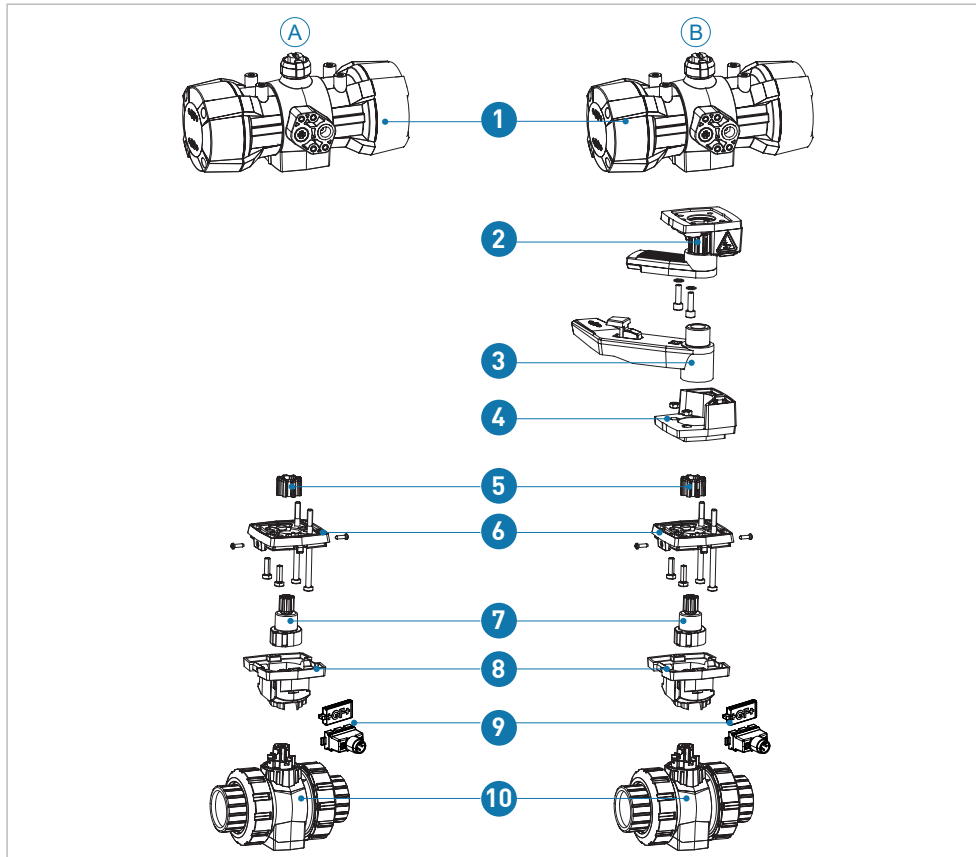

- A** Type 546 Pro P, with pneumatic actuator type PPA, without manual override
- B** Type 546 Pro P, with pneumatic actuator type PPA, with manual override
- 1** Actuator type PPA
- 2** Coupling lever with upper intermediate element
- 3** Control lever
- 4** Lower intermediate element
- 5** Adapter
- 6** Adapter plate
- 7** Coupling piece
- 8** Interface housing
- 9** Labelling clip or double sensor for electrical position feedback
- 10** Ball Valve Type 546 Pro

Specification

Dimensions (standard 5.6 bar)	PPA08	DN10 – DN20
	PPA15	DN25 – DN32
	PPA40	DN40 – DN50
	PPA80	DN65 – DN100
Base type	546 Pro	
Materials	PVC-U, PVC-C, ABS, PP-H, PVDF	
Gasket materials	O-rings	EPDM, FKM (other sealings on request)
	Ball seat	PTFE, PVDF
Pressure rating	PN10	
Connections	Socket, spigot, flanges, threaded socket	
Standards	ISO, BS, ASTM, JIS	

i The following technical data can be found in the Planning Fundamentals under Ball Valve type 546 Pro, manually operated:

- Pressure-temperature diagram
- Pressure loss
- Flow characteristics
- Kv values
- Reference values for fastening screws

Technical basics

- The actuators are available with the functions fail-safe to close (FC), fail-safe to open (FO) or double-acting (DA) and are provided with an optical position indicator.
- The housing of the actuator is made of fiberglass-reinforced polypropylene (PP-GF) and therefore has low flammability.
- For simple installation of positioners, limit switches and accessories, the actuators have an integrated NAMUR interface. For reliable electrical feedback, the valves are equipped with a interface module that is installed between valve body and actuator.

Valve handling

Installation notes

- The type 546 Pro P ball valves can be controlled to the OPEN and CLOSED positions via a built-on solenoid valve. The solenoid valve is either supplied ex GF works or installed by the customer.
- The OPEN and CLOSED positions can be indicated by the double sensor (available as an accessory), which send an electric signal to the plant control system or optically output the valve position (red/green LED).

Maintenance notes

Ball valves require few maintenance under normal operating conditions (clear water).

However, the following measures must be considered:

- Regularly check that no medium escapes to the outside.
- We recommend a function test for ball type valves that are kept permanently in the same position 1 – 2 times per year to check functionality.

For frequent control operations or due to chemical attack on the sealing material, it may become necessary to replace parts inside the valve or the complete valve/ central part. For this purpose, the valve must be removed from the piping system.



Installation and maintenance must be performed according to the corresponding installation instructions. The installation manual is part of the product, see also the online product catalog at www.gfps.com

Dimensions

Type 546 Pro P, FC, with manual override, solvent cement sockets

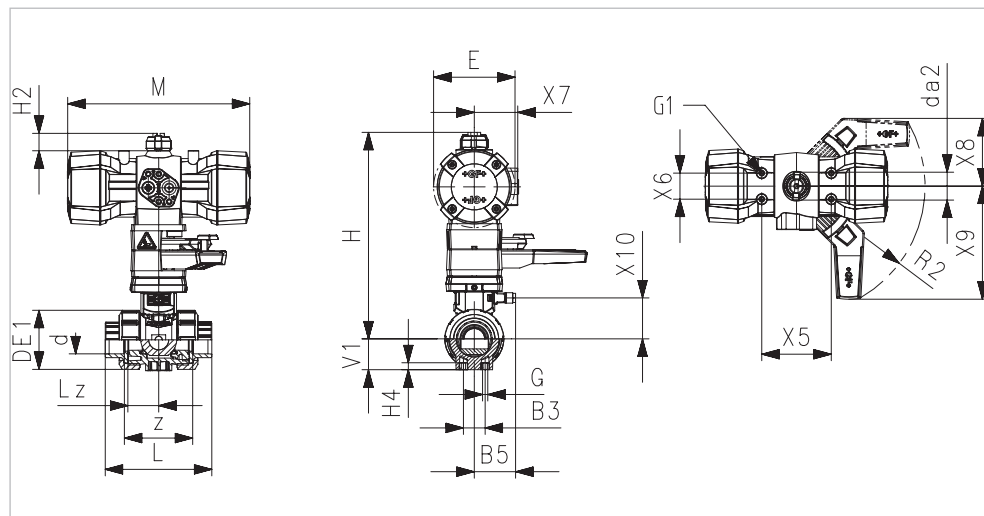

d (mm)	DN (mm)	Size (inch)	Actuator	B3 (mm)	B5 (mm)	DE1 (mm)	E (mm)	G (mm)	G1 (mm)	H (mm)	H2 (mm)	H4 (mm)	L (mm)	Lz (mm)
16	10	3/8	PPA08	25	25	50	74	M6	M5	215	20	12	92	28
20	15	1/2	PPA08	25	25	50	74	M6	M5	215	20	12	95	28
25	20	3/4	PPA08	25	25	58	74	M6	M5	219	20	12	110	33
32	25	1	PPA15	25	25	68	94	M8	M5	238	20	12	123	36
40	32	1 1/4	PPA15	45	45	84	94	M8	M5	244	20	15	146	43
50	40	1 1/2	PPA40	45	45	97	120	M8	M5	273	20	15	157	45
63	50	2	PPA40	45	45	124	120	M8	M5	288	20	15	183	51

d (mm)	DN (mm)	Size (inch)	M (mm)	R2 (mm)	V1 (mm)	X5 (mm)	X6 (mm)	X7 (mm)	X8 (mm)	X9 (mm)	X10 (mm)	da2 (mm)	z (mm)
16	10	3/8	159	R150	27	80	30	43	78	132	38.0	33	64
20	15	1/2	159	R150	27	80	30	43	78	132	38.0	33	64
25	20	3/4	159	R150	30	80	30	43	78	132	41.9	33	72
32	25	1	211	R150	36	80	30	51	78	132	47.0	33	79
40	32	1 1/4	211	R150	44	80	30	51	78	132	53.5	33	94
50	40	1 1/2	246	R150	51	80	30	62	78	132	62.75	33	95
63	50	2	246	R150	64	80	30	62	78	132	77.0	33	107

Dimensions based on configuration with PVC-U ball valve, metric

Type 546 Pro P, FC, with manual override, solvent cement spigots

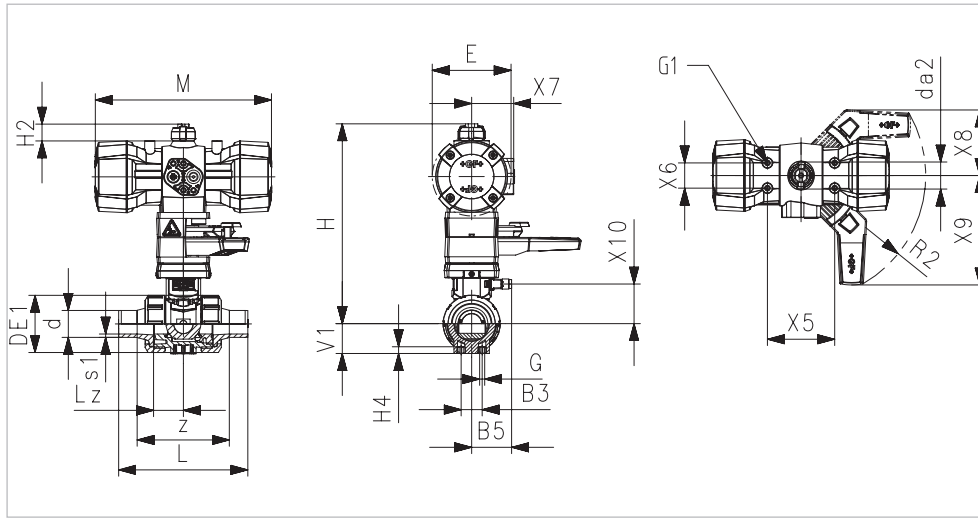

d (mm)	DN (mm)	Size (inch)	Actuator	B3 (mm)	B5 (mm)	DE1 (mm)	E (mm)	G (mm)	G1 (mm)	H (mm)	H2 (mm)	H4 (mm)	L (mm)	Lz (mm)
16	10	3/8	PPA08	25	16.2	50	74	M6	M5	215	20	12	114	28
20	15	1/2	PPA08	25	16.2	50	74	M6	M5	215	20	12	124	28
25	20	3/4	PPA08	25	17.5	58	74	M6	M5	219	20	12	144	33
32	25	1	PPA15	25	17.5	68	94	M8	M5	238	20	12	154	36
40	32	1 1/4	PPA15	45	23.3	84	94	M8	M5	244	20	15	174	43
50	40	1 1/2	PPA40	45	23.3	97	120	M8	M5	273	20	15	194	45
63	50	2	PPA40	45	24.3	124	120	M8	M5	288	20	15	224	51

d (mm)	DN (mm)	Size (inch)	M (mm)	R2 (mm)	V1 (mm)	X5 (mm)	X6 (mm)	X7 (mm)	X8 (mm)	X9 (mm)	X10 (mm)	da2 (mm)	s1 (mm)	z (mm)
16	10	3/8	159	R150	27	80	30	43	78	132	38.0	33	3.0	88
20	15	1/2	159	R150	27	80	30	43	78	132	38.0	33	3.0	96
25	20	3/4	159	R150	30	80	30	43	78	132	41.9	33	3.0	112
32	25	1	211	R150	36	80	30	51	78	132	47.0	33	4.0	118
40	32	1 1/4	211	R150	44	80	30	51	78	132	53.5	33	4.5	134
50	40	1 1/2	246	R150	51	80	30	62	78	132	62.75	33	5.5	148
63	50	2	246	R150	64	80	30	62	78	132	77.0	33	7.0	170

Dimensions based on configuration with PVC-U ball valve, metric

Type 546 Pro P, FC, with manual override, threaded sockets, Rp

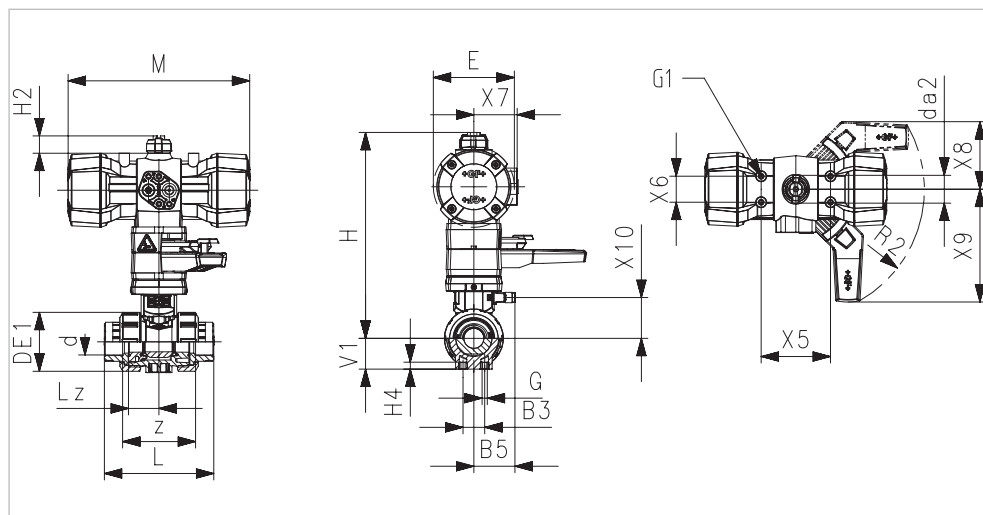

d (mm)	DN (mm)	Size (inch)	Actuator	B3 (mm)	B5 (mm)	DE1 (mm)	E (mm)	G (mm)	G1 (mm)	H (mm)	H2 (mm)	H4 (mm)	L (mm)	Lz (mm)
16	10	3/8	PPA08	25	16.2	50	74	M6	M5	215	20	12	95	28
20	15	1/2	PPA08	25	16.2	50	74	M6	M5	215	20	12	100	28
25	20	3/4	PPA08	25	17.5	58	74	M6	M5	219	20	12	114	33
32	25	1	PPA15	25	17.5	68	94	M8	M5	238	20	12	127	36
40	32	1 1/4	PPA15	45	23.3	84	94	M8	M5	244	20	15	146	43
50	40	1 1/2	PPA40	45	23.3	97	120	M8	M5	273	20	15	152	45
63	50	2	PPA40	45	24.3	124	120	M8	M5	288	20	15	177	51

d (mm)	DN (mm)	Size (inch)	M (mm)	R2 (mm)	V1 (mm)	X5 (mm)	X6 (mm)	X7 (mm)	X8 (mm)	X9 (mm)	X10 (mm)	da2 (mm)	z (mm)
16	10	3/8	159	R150	27	80	30	43	78	132	38.0	33	69
20	15	1/2	159	R150	27	80	30	43	78	132	38.0	33	67
25	20	3/4	159	R150	30	80	30	43	78	132	41.9	33	78
32	25	1	211	R150	36	80	30	51	78	132	47.0	33	85
40	32	1 1/4	211	R150	44	80	30	51	78	132	53.5	33	100
50	40	1 1/2	246	R150	51	80	30	62	78	132	62.75	33	106
63	50	2	246	R150	64	80	30	62	78	132	77.0	33	121

Dimensions based on configuration with PVC-U ball valve, metric

Type 546 Pro P, FC, with manual override, fixed flanges

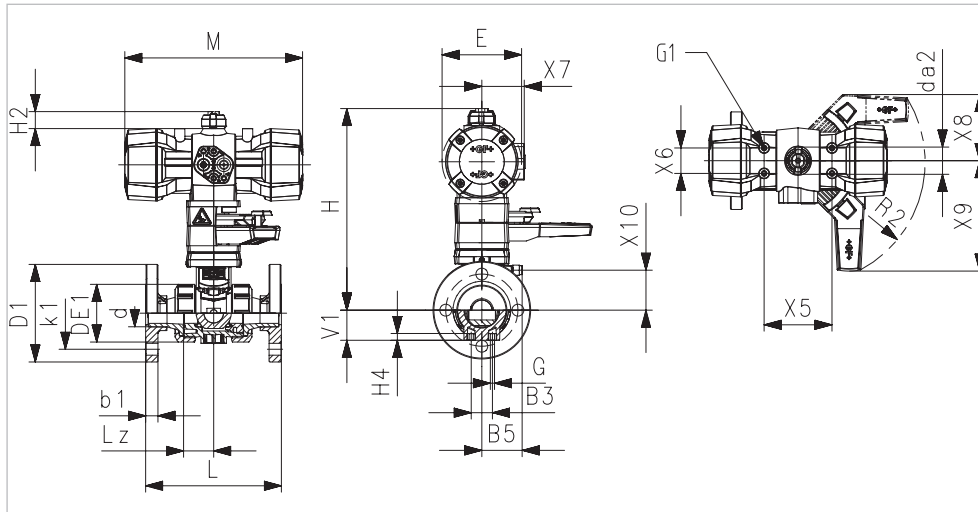

d (mm)	DN (mm)	Size (inch)	Actuator	B3 (mm)	B5 (mm)	D1 (mm)	DE1 (mm)	E (mm)	G (mm)	G1 (mm)	H (mm)	H2 (mm)	H4 (mm)	L (mm)	Lz (mm)
20	15	½	PPA08	25	16.2	95	50	74	M6	M5	215	20	12	130	28
25	20	¾	PPA08	25	17.5	105	58	74	M6	M5	219	20	12	150	33
32	25	1	PPA15	25	17.5	115	68	94	M8	M5	238	20	12	160	36
40	32	1 ¼	PPA15	45	23.3	140	84	94	M8	M5	244	20	15	180	43
50	40	1 ½	PPA40	45	23.3	150	97	120	M8	M5	273	20	15	200	45
63	50	2	PPA40	45	24.3	165	124	120	M8	M5	288	20	15	230	51

d (mm)	DN (mm)	Size (inch)	M (mm)	R2 (mm)	V1 (mm)	X5 (mm)	X6 (mm)	X7 (mm)	X8 (mm)	X9 (mm)	X10 (mm)	b1 (mm)	da2 (mm)	k1 (mm)
20	15	½	159	R150	27	80	30	43	78	132	38.0	12	33	56
25	20	¾	159	R150	30	80	30	43	78	132	41.9	12	33	75
32	25	1	211	R150	36	80	30	51	78	132	47.0	14	33	85
40	32	1 ¼	211	R150	44	80	30	51	78	132	53.5	16	33	100
50	40	1 ½	246	R150	51	80	30	62	78	132	62.75	16	33	110
63	50	2	246	R150	64	80	30	62	78	132	77.0	18	33	125

Dimensions based on configuration with PVC-U ball valve, metric

Type 546 Pro P, FC, without manual override, solvent cement sockets

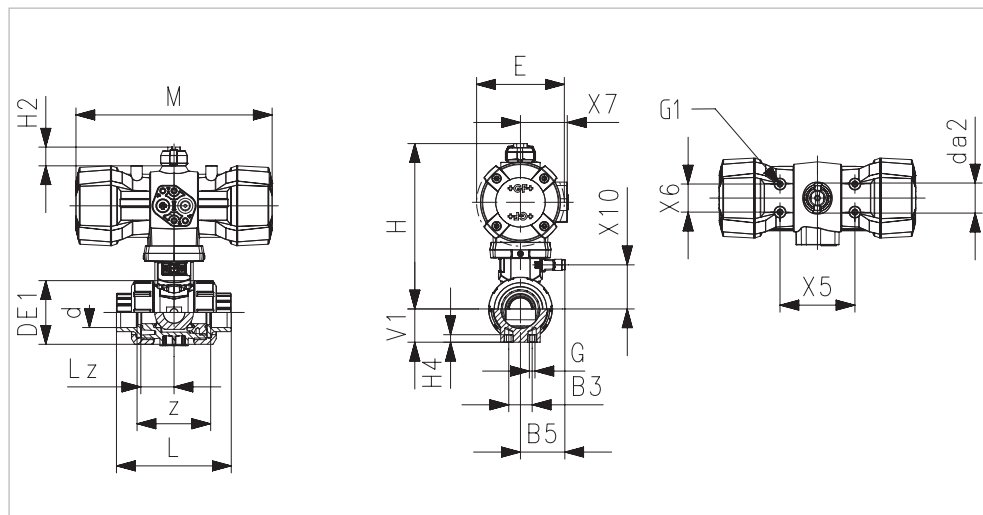

d (mm)	DN (mm)	Size (inch)	Actuator	B3 (mm)	B5 (mm)	DE1 (mm)	E (mm)	G (mm)	G1 (mm)	H (mm)	H2 (mm)	H4 (mm)
16	10	3/8	PPA08	25	16.2	50	74	M6	M5	155	20	12
20	15	1/2	PPA08	25	16.2	50	74	M6	M5	155	20	12
25	20	3/4	PPA08	25	17.5	58	74	M6	M5	159	20	12
32	25	1	PPA15	25	17.5	68	94	M8	M5	178	20	12
40	32	1 1/4	PPA15	45	23.3	84	94	M8	M5	184	20	15
50	40	1 1/2	PPA40	45	23.3	97	120	M8	M5	213	20	15
63	50	2	PPA40	45	24.3	124	120	M8	M5	228	20	15
75	65	2 1/2	PPA80	70	28.5	166	142	M8	M5	277	20	15
90	80	3	PPA80	70	28.5	200	142	M8	M5	289	20	15
110	100	4	PPA80	120	28.5	238	142	M12	M5	324	20	22

d (mm)	DN (mm)	Size (inch)	L (mm)	Lz (mm)	M (mm)	V1 (mm)	X5 (mm)	X6 (mm)	X7 (mm)	X10 (mm)	da2 (mm)	z (mm)
16	10	3/8	92	28	159	27	80	30	43	38.0	33	64
20	15	1/2	95	28	159	27	80	30	43	38.0	33	64
25	20	3/4	110	33	159	30	80	30	43	41.9	33	72
32	25	1	123	36	211	36	80	30	51	47.0	33	79
40	32	1 1/4	146	43	211	44	80	30	51	53.5	33	94
50	40	1 1/2	157	45	246	51	80	30	62	62.75	33	95
63	50	2	183	51	246	64	80	30	62	77.0	33	107
75	65	2 1/2	233	68	343	85	80	30	74	119.0	33	144
90	80	3	254	71	343	105	80	30	74	131.0	33	151
110	100	4	301	82	343	123	80	30	74	145.0	33	174

Dimensions based on configuration with PVC-U ball valve, metric

Type 546 Pro P, FC, without manual override, solvent cement spigots

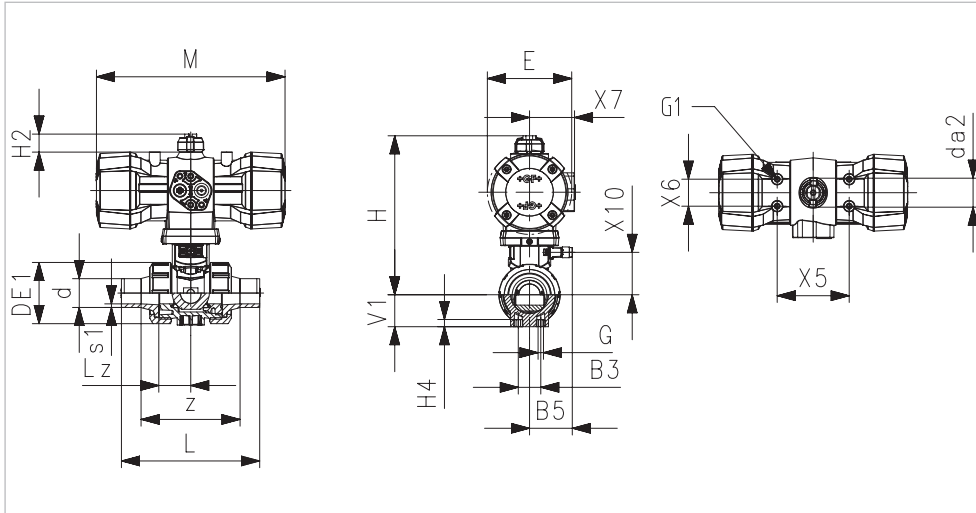

d (mm)	DN (mm)	Size (inch)	Actuator	B3 (mm)	B5 (mm)	DE1 (mm)	E (mm)	G (mm)	G1 (mm)	H (mm)	H2 (mm)	H4 (mm)
16	10	3/8	PPA08	25	16.2	50	74	M6	M5	155	20	12
20	15	1/2	PPA08	25	16.2	50	74	M6	M5	155	20	12
25	20	3/4	PPA08	25	17.5	58	74	M6	M5	159	20	12
32	25	1	PPA15	25	17.5	68	94	M8	M5	178	20	12
40	32	1 1/4	PPA15	45	23.3	84	94	M8	M5	184	20	15
50	40	1 1/2	PPA40	45	23.3	97	120	M8	M5	213	20	15
63	50	2	PPA40	45	24.3	124	120	M8	M5	228	20	15
75	65	2 1/2	PPA80	70	28.5	166	142	M8	M5	277	20	15
90	80	3	PPA80	70	28.5	200	142	M8	M5	289	20	15
110	100	4	PPA80	120	28.5	238	142	M12	M5	324	20	22

d (mm)	DN (mm)	Size (inch)	L (mm)	Lz (mm)	M (mm)	V1 (mm)	X5 (mm)	X6 (mm)	X7 (mm)	X10 (mm)	da2 (mm)	s1 (mm)	z (mm)
16	10	3/8	114	28	159	27	80	30	43	38.0	33	3.0	64
20	15	1/2	124	28	159	27	80	30	43	38.0	33	3.0	64
25	20	3/4	144	33	159	30	80	30	43	41.9	33	3.0	72
32	25	1	154	36	211	36	80	30	51	47.0	33	4.0	79
40	32	1 1/4	174	43	211	44	80	30	51	53.5	33	4.5	94
50	40	1 1/2	194	45	246	51	80	30	62	62.75	33	5.5	95
63	50	2	224	51	246	64	80	30	62	77.0	33	7.0	107
75	65	2 1/2	284	68	343	85	80	30	74	119.0	33	8.5	144
90	80	3	300	71	343	105	80	30	74	131.0	33	10.0	151
110	100	4	340	82	343	123	80	30	74	145.0	33	12.0	174

Dimensions based on configuration with PP-H ball valve, metric

Type 546 Pro P, FC, without manual override, threaded sockets, Rp

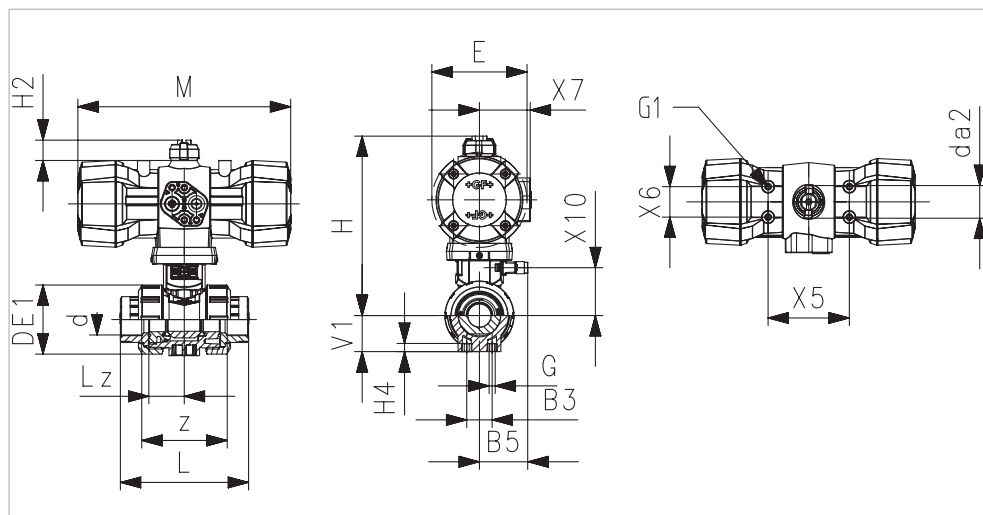

d (mm)	DN (mm)	Size (inch)	Actuator	B3 (mm)	B5 (mm)	DE1 (mm)	E (mm)	G (mm)	G1 (mm)	H (mm)	H2 (mm)	H4 (mm)
16	10	3/8	PPA08	25	16.2	50	74	M6	M5	155	20	12
20	15	1/2	PPA08	25	16.2	50	74	M6	M5	155	20	12
25	20	3/4	PPA08	25	17.5	58	74	M6	M5	159	20	12
32	25	1	PPA15	25	17.5	68	94	M8	M5	178	20	12
40	32	1 1/4	PPA15	45	23.3	84	94	M8	M5	184	20	15
50	40	1 1/2	PPA40	45	23.3	97	120	M8	M5	213	20	15
63	50	2	PPA40	45	24.3	124	120	M8	M5	228	20	15
75	65	2 1/2	PPA80	70	28.5	166	142	M8	M5	277	20	15
90	80	3	PPA80	70	28.5	200	142	M8	M5	289	20	15
110	100	4	PPA80	120	28.5	238	142	M12	M5	324	20	22

d (mm)	DN (mm)	Size (inch)	L (mm)	Lz (mm)	M (mm)	V1 (mm)	X5 (mm)	X6 (mm)	X7 (mm)	X10 (mm)	da2 (mm)	z (mm)
16	10	3/8	95	28	159	27	80	30	43	38.0	33	69
20	15	1/2	100	28	159	27	80	30	43	38.0	33	67
25	20	3/4	114	33	159	30	80	30	43	41.9	33	78
32	25	1	127	36	211	36	80	30	51	47.0	33	85
40	32	1 1/4	146	43	211	44	80	30	51	53.5	33	100
50	40	1 1/2	152	45	246	51	80	30	62	62.75	33	106
63	50	2	177	51	246	64	80	30	62	77.0	33	121
75	65	2 1/2	233	68	343	85	80	30	74	119.0	33	144
90	80	3	254	71	343	105	80	30	74	131.0	33	151
110	100	4	301	82	343	123	80	30	74	145.0	33	174

Dimensions based on configuration with PVC-U ball valve, metric

Type 546 Pro P, FC, without manual override, backing flanges

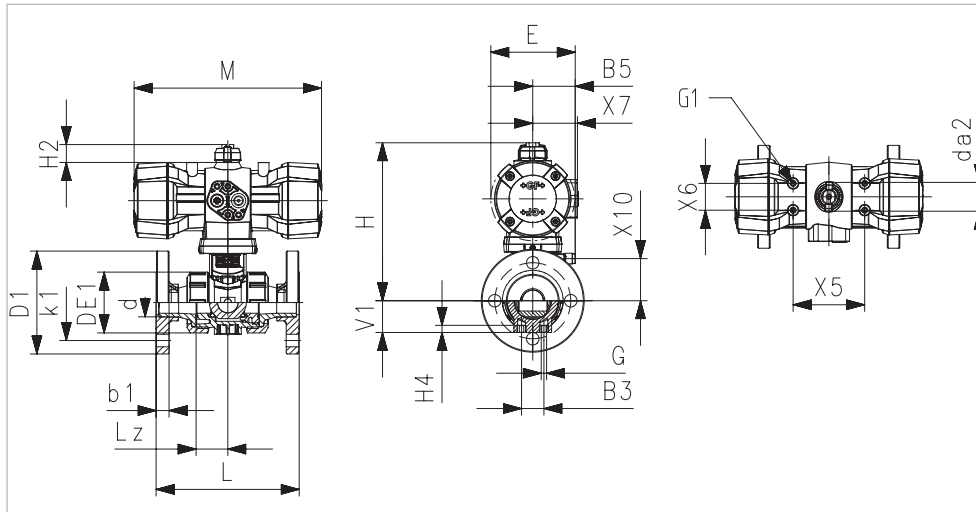

d (mm)	DN (mm)	Size (inch)	Actuator	B3 (mm)	B5 (mm)	D1 (mm)	DE1 (mm)	E (mm)	G (mm)	G1 (mm)	H (mm)	H2 (mm)	H4 (mm)
75	65	2 ½	PPA80	70	28.5	166	166	142	M8	M5	277	20	15
90	80	3	PPA80	70	28.5	200	200	142	M8	M5	289	20	15
110	100	4	PPA80	120	28.5	238	238	142	M12	M5	324	20	22

d (mm)	DN (mm)	Size (inch)	L (mm)	Lz (mm)	M (mm)	V1 (mm)	X5 (mm)	X6 (mm)	X7 (mm)	X10 (mm)	b1 (mm)	da2 (mm)	k1 (mm)
75	65	2 ½	290	68	343	85	80	30	74	119.0	18	33	140
90	80	3	310	71	343	105	80	30	74	131.0	20	33	150
110	100	4	350	82	343	123	80	30	74	145.0	20	33	175

Dimensions based on configuration with PVC-U ball valve, metric

Accessories

- Emergency manual override -10 up to +50 °C
- Double sensor for electrical position feedback
- 3/2-way pilot solenoid valve type PV94/95
- 3/2 – 5/2-way pilot solenoid valve type MNL532
- 4/2-way pilot solenoid valve type 5470
- Pilot valve cluster type PV2000
- Digital positioner type RPC
- Position indicator – Feedback box
- AS-Interface
- See accessories for pneumatic actuator PPA



For further information on accessories, refer to the online product catalog at www.gfps.com

The information and technical data (altogether "Data") herein are not binding, unless explicitly confirmed in writing. The Data neither constitutes any expressed, implied or warranted characteristics, nor guaranteed properties or a guaranteed durability. All Data is subject to modification. The General Terms and Conditions of Sale of Georg Fischer Piping Systems apply.

02/2025-A

© Georg Fischer Piping Systems Ltd, 8201 Schaffhausen/Switzerland

Tel. +41 52 631 11 11 • www.gfps.com • E-Mail: info.ps@georgfischer.com