

Strainer Type 305



Product description

To protect valves, sensors and pumps from pollutants, we recommend the use of strainers of Type 305. This ensures reliable operation and extended service life for your components. The broad product range includes various materials, end connectors and standards, suitable for a wide variety of applications.

Function

The media flow is conducted through the sieve in the strainer from the inside to the outside. This keeps back and collects the dirt particles.

Applications

- Chemical process industry
- Industrial plant engineering
- Cooling processes
- Water treatment

Benefits/features

- Simple and quick installation
- Transparent design (transparent PVC) for checking the amount of contamination visually
- All parts that come into contact with the medium are manufactured using highly resistant thermoplastics
- Radially removable (PP-H)
- Easy dismantling for cleaning or replacing the filter
- Integrated threaded connections
- Guarantees reliable operation of the plant through simple dismantling
- The components used extend service life

Flow media

Neutral and aggressive liquid or gaseous media, as long as the components of the valve that come into contact with the media are resistant at the operating temperature in question according to the resistance table.

Technical data

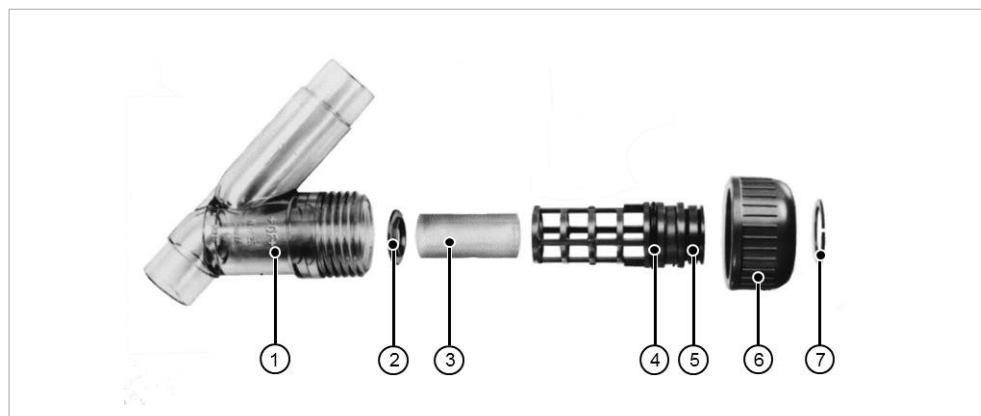

- 1 Housing
- 2 Support ring
- 3 Slotted casing
- 4 Body seal
- 5 Screen cage
- 6 Cap nut
- 7 Circlip

Specification

| | | |
|-----------------------------|--|--------------------------------|
| Dimensions | d20/DN15 – d63/DN50, ½" – 2" | |
| | PVC-U: d20/DN15 - d90/DN80, ½" – 3" | |
| Valve body materials | PVC-U, PVC-C, ABS, PP-H, transparent PVC-U | |
| Gasket materials | EPDM, FKM | |
| Pressure level | PN10 | |
| Hole diameter | PVC-U slotted casing | 0.5 mm, 0.8 mm, 1.4 mm, 2.2 mm |
| | Stainless steel slotted casing | 0.5 mm |
| Connections | Solvent cement sockets | |
| | Solvent cement spigots | |
| | Fusion sockets | |
| Product standard | EN ISO 21787 | |
| Test standard | ISO 9393-2, EN 12266-1 | |
| Approvals | KTW 2013 | |

Kv 100 values

PVC-U/PP screen hole diameter 0.5 – 2.2 mm

| DN (mm) | Inch (inch) | d #(mm) | Kv 100 (l/min) (Δp = 1 bar) | Cv 100 (US gal./min) (Δp = 1 psi) | kv 100 (m ³ /h) (Δp = 1 bar) |
|------------|----------------|------------|-----------------------------------|---|---|
| 15 | ½ | 20 | 35 | 2.5 | 2.1 |
| 20 | ¾ | 25 | 65 | 4.6 | 3.9 |
| 25 | 1 | 32 | 90 | 6.3 | 5.4 |
| 32 | 1¼ | 40 | 155 | 10.9 | 9.3 |
| 40 | 1½ | 50 | 225 | 15.8 | 13.5 |
| 50 | 2 | 63 | 370 | 25.9 | 22.2 |
| 65 | 2½ | 75 | 575 | 40.3 | 34.5 |
| 80 | 3 | 90 | 955 | 66.9 | 57.5 |

Stainless steel screen mesh size 0.5 mm

| DN (mm) | Inch (inch) | d (mm) | Kv 100 (l/min) (Δp = 1 bar) | Cv 100 (US gal./min) (Δp = 1 psi) | kv 100 (m ³ /h) (Δp = 1 bar) |
|------------|----------------|-----------|-----------------------------------|---|---|
| 15 | ½ | 20 | 35 | 2.5 | 2.1 |
| 20 | ¾ | 25 | 60 | 4.2 | 3.6 |
| 25 | 1 | 32 | 85 | 6.0 | 5.1 |
| 32 | 1¼ | 40 | 130 | 9.1 | 7.8 |
| 40 | 1½ | 50 | 200 | 14.0 | 12.0 |
| 50 | 2 | 63 | 330 | 23.1 | 19.8 |
| 65 | 2½ | 75 | 460 | 32.2 | 27.6 |
| 80 | 3 | 90 | 665 | 46.6 | 40.0 |

Pressure-temperature diagrams

The following pressure-temperature diagrams are based on a lifetime of 25 years and water or similar media.

T Temperature (°C, °F)

P Permissible pressure (bar, psi)

PVC-U

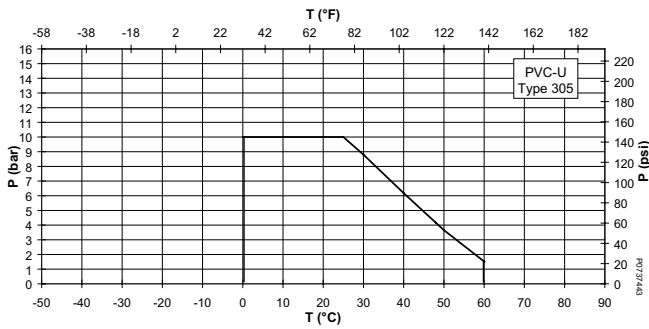

PVC-C

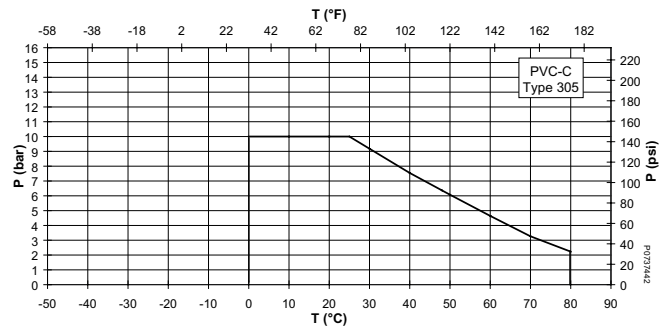

ABS

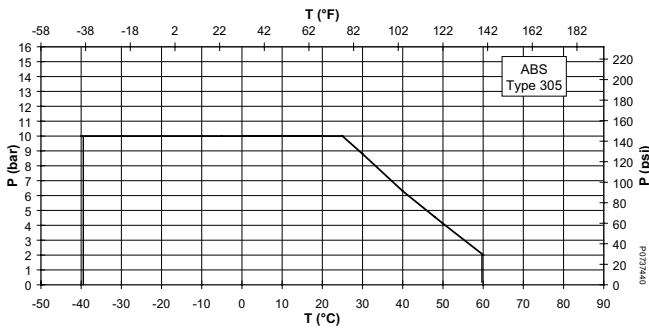

PP

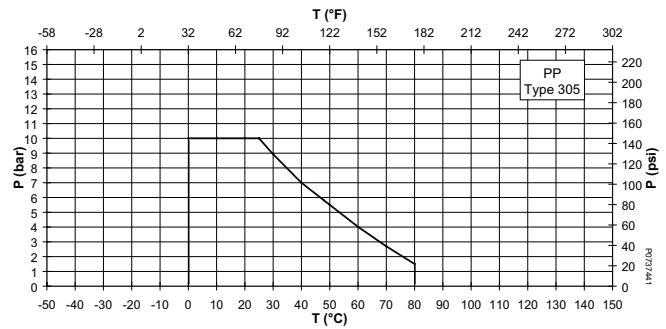

Pressure losses

PVC-U/PP screens (hole diameter 0.5 – 2.2 mm)

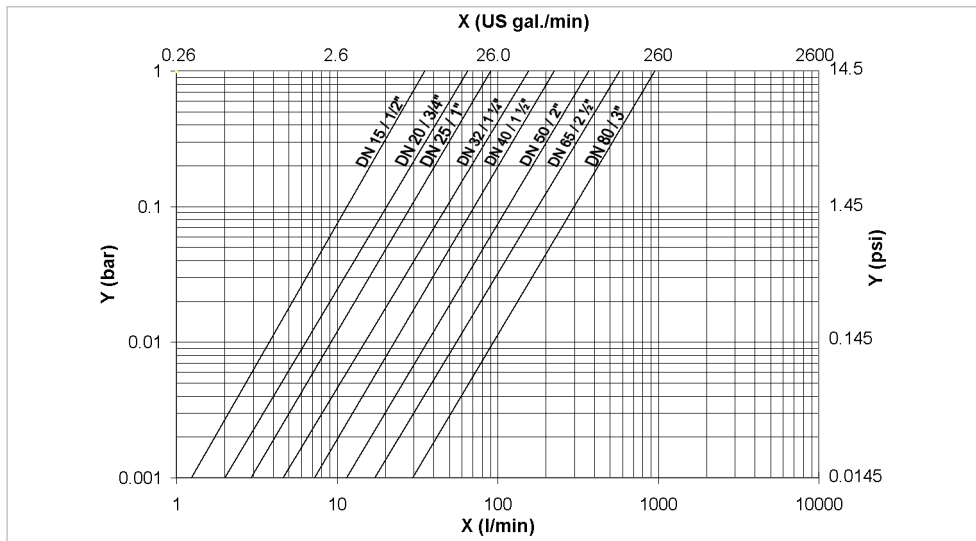

- X Flow rate (l/min, US gal./min)
- Y Pressure loss Δp (bar, psi)

Stainless steel screens (mesh size: ca. 0.5 mm)

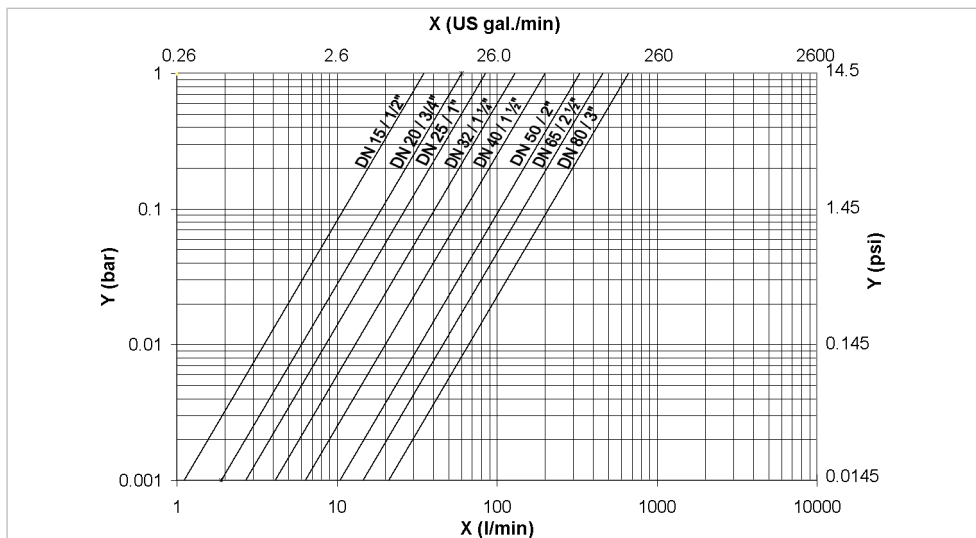

- X Flow rate (l/min, US gal./min)
- Y Pressure loss Δp (bar, psi)

Dimensions

PVC-U, PVC-C solvent cement spigot, metric

| DN (mm) | d (mm) | D (mm) | L (mm) | L1 (mm) | L2 (mm) | H (mm) | Zoll (inch) |
|---------|--------|--------|--------|---------|---------|--------|-------------|
| 15 | 20 | 43 | 124 | 130 | 28 | 65 | 1/2 |
| 20 | 25 | 47 | 144 | 150 | 37 | 76 | 3/4 |
| 25 | 32 | 56 | 154 | 160 | 37 | 90 | 1 |
| 32 | 40 | 64 | 174 | 180 | 44 | 104 | 1 1/4 |
| 40 | 50 | 82 | 194 | 200 | 48 | 124 | 1 1/2 |
| 50 | 63 | 95 | 224 | 230 | 60 | 148 | 2 |
| 65 | 75 | 106 | 284 | 290 | 74 | 188 | 2 1/2 |
| 80 | 90 | 120 | 300 | 310 | 85 | 205 | 3 |

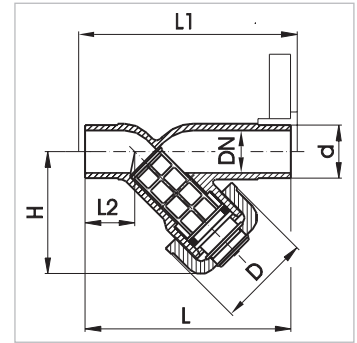

PVC-U solvent cement spigot, ASTM

| DN (mm) | D (mm) | L (mm) | L1 (mm) | L2 (mm) | H (mm) | Zoll (inch) |
|---------|--------|--------|---------|---------|--------|-------------|
| 15 | 43 | 143 | 149 | 37 | 65 | 1/2 |
| 20 | 47 | 160 | 166 | 45 | 76 | 3/4 |
| 25 | 56 | 174 | 180 | 47 | 90 | 1 |
| 32 | 64 | 188 | 194 | 53 | 104 | 1 1/4 |
| 40 | 82 | 205 | 211 | 54 | 124 | 1 1/2 |
| 50 | 95 | 225 | 231 | 63 | 148 | 2 |
| 80 | 120 | 311 | 321 | 90 | 205 | 3 |

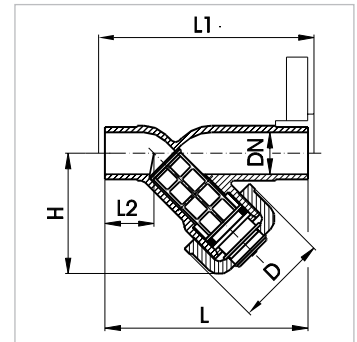

PVC-U solvent cement unions, JIS

| DN (mm) | d (mm) | D (mm) | L (mm) | L1 (mm) | H (mm) | Zoll (inch) |
|---------|--------|--------|--------|---------|--------|-------------|
| 15 | 20 | 43 | 195.4 | 164 | 65 | 1/2 |
| 20 | 25 | 47 | 210.1 | 170 | 76 | 3/4 |
| 25 | 32 | 56 | 228.0 | 180 | 90 | 1 |
| 32 | 40 | 64 | 261.5 | 204 | 102 | 1 1/4 |
| 40 | 50 | 82 | 294.3 | 228 | 123 | 1 1/2 |
| 50 | 63 | 95 | 348.3 | 226 | 147 | 2 |

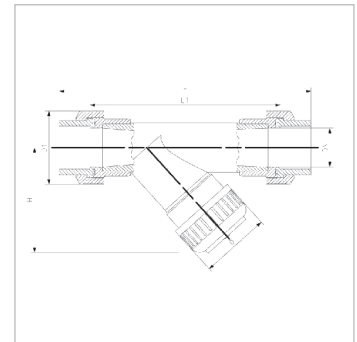

PVC-U fixed flanges, JIS

| DN (mm) | d (mm) | D (mm) | L (mm) | H (mm) | Zoll (inch) |
|---------|--------|--------|--------|--------|-------------|
| 15 | 20 | 95 | 130 | 65 | 1/2 |
| 20 | 25 | 100 | 150 | 76 | 3/4 |
| 25 | 32 | 125 | 160 | 90 | 1 |
| 32 | 40 | 135 | 180 | 102 | 1 1/4 |
| 40 | 50 | 140 | 200 | 123 | 1 1/2 |
| 50 | 63 | 155 | 230 | 147 | 2 |
| 65 | 75 | 185 | 290 | 188 | 2 1/2 |
| 80 | 90 | 200 | 310 | 205 | 3 |

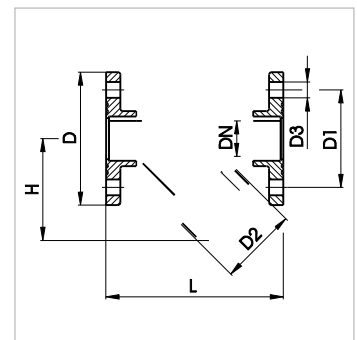

ABS solvent cement spigot, metric

| DN (mm) | d (mm) | D (mm) | L (mm) | L1 (mm) | L2 (mm) | H (mm) | Zoll (inch) |
|---------|--------|--------|--------|---------|---------|--------|-------------|
| 15 | 20 | 48 | 124 | 130 | 28 | 65 | 1/2 |
| 20 | 25 | 54 | 144 | 150 | 37 | 76 | 3/4 |
| 25 | 32 | 62 | 154 | 160 | 37 | 90 | 1 |
| 32 | 40 | 71 | 174 | 180 | 44 | 104 | 1 1/4 |
| 40 | 50 | 88 | 194 | 200 | 48 | 124 | 1 1/2 |
| 50 | 63 | 103 | 224 | 230 | 60 | 148 | 2 |

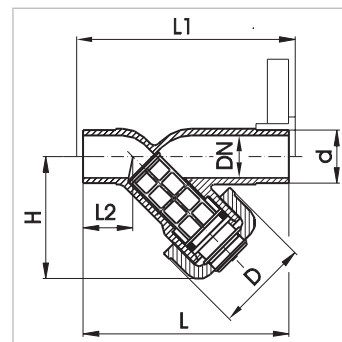

PP-H fusion sockets, metric

| DN (mm) | d (mm) | D (mm) | L (mm) | L2 (mm) | H (mm) | Zoll (inch) |
|---------|--------|--------|--------|---------|--------|-------------|
| 15 | 20 | 52 | 168 | 130 | 75 | 1/2 |
| 20 | 25 | 62 | 192 | 150 | 80 | 3/4 |
| 25 | 32 | 68 | 206 | 160 | 90 | 1 |
| 32 | 40 | 85 | 230 | 180 | 110 | 1 1/4 |
| 40 | 50 | 85 | 256 | 200 | 125 | 1 1/2 |
| 50 | 63 | 102 | 294 | 230 | 150 | 2 |

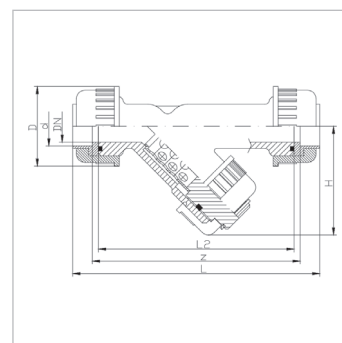

PP-H butt fusion spigots, metric

| DN (mm) | d (mm) | D (mm) | L (mm) | L2 (mm) | H (mm) | Zoll (inch) |
|---------|--------|--------|--------|---------|--------|-------------|
| 15 | 20 | 52 | 238 | 130 | 75 | 1/2 |
| 20 | 25 | 62 | 264 | 150 | 80 | 3/4 |
| 25 | 32 | 68 | 280 | 160 | 90 | 1 |
| 32 | 40 | 85 | 306 | 180 | 110 | 1 1/4 |
| 40 | 50 | 85 | 332 | 200 | 125 | 1 1/2 |
| 50 | 63 | 102 | 368 | 230 | 150 | 2 |

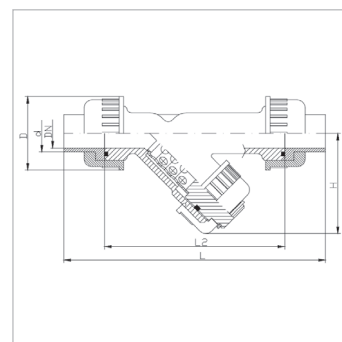

⚠ Installation and maintenance must be performed in accordance with the corresponding installation manual. The installation manual is provided with the product, see also the online product catalogue at www.gfps.com

The information and technical data (altogether "Data") herein are not binding, unless explicitly confirmed in writing. The Data neither constitutes any expressed, implied or warranted characteristics, nor guaranteed properties or a guaranteed durability. All Data is subject to modification. The General Terms and Conditions of Sale of Georg Fischer Piping Systems apply.

07/2023-A

© Georg Fischer Piping Systems Ltd, 8201 Schaffhausen/Switzerland
Tel. +41 52 631 11 11 • www.gfps.com • E-Mail: info.ps@georgfischer.com