

## Type 2291 Guided Wave Radar Level Transmitter



### Product description

The type 2291 Guided Wave Radar level transmitter is designed for continuous level measuring of conductive or non-conductive liquids, pulps and solids. The 2291 level gauge operates based on the well-known TDR (Time Domain Reflectometry) principle. Micropulses are sent along a probe guide at the speed of light. As soon as the impulse reaches the surface of the medium, it is reflected back to the electronic module. Level distance is directly proportional to the flight time of the impulse.

The reflected signal is dependent on the dielectric constant of the material; the feasibility of the measurement is  $\epsilon_r \geq 1.9$ . The TDR technology is unaffected by the properties of the medium as well as that of the space above it. Measurement is also unaffected by the change in the physical properties of the materials such as temperature, pressure, dielectric constant.

### Features

- Measuring range up to 6 m (19.6 ft)
- Accuracy:  $\pm 5$  mm (0.2 in)
- PP / PFA coated probes available on request
- Rod & cable versions available
- Minimum  $\epsilon_r$  1.9
- 2-wire version
- Graphic LCD display
- 4 to 20 mA + HART output
- Medium temperature range:  $-30$  °C to  $+90$ °C ( $-22$  °F to  $+194$  °F)
- Maximum process pressure: 40 bar (580 psi)
- IP67 protection
- ATEX option



## Applications

- Inventory Tanks
- Day Tanks
- Process Vessels for Mixing & Batching
- Bypass Applications (requires calibration)
- Stilling-wells
- Powders
- Slightly Conductive Foams
- Low Dielectric Constant Liquids

## Specifications

General	
Measured Values	Level, Distance; Calculated values: Volume, Mass
Measuring Range	Depends on the probe type and dielectric constant ( $\epsilon_r$ ) of the measured medium
Probe types	Mono cable, mono rod
Accuracy: Linearity Error <sup>1</sup>	For liquids: $\pm 5$ mm (0.2 inch), if probe length $\pm 10$ m (32 feet); $\pm 0.05$ % of the probe length
Accuracy: Resolution	$\pm 3$ $\mu$ A
Minimal $\epsilon_r$ of the Medium	1.9
Power Supply	18 V... 35 V DC
Output: Digital Communication	4-20 mA + HART
Output: Display	Graphical LCD display unit
Medium Temperature	-30 °C... +90 °C (-22 °F... +194 °F),
Maximum Medium Pressure	4 MPa (40 bar g/ 580 psi g); with plastic lined flange: max. 2.5 MPa (25 bar g/ 363 psi g)
Ambient Temperature	-20 °C... +60 °C (-4 °F... +140 °F)
Process Connection	1" BSP, 1" NPT Thread
Ingress Protection	IP 67, NEMA 6 equivalent
Electrical Connection	2x M20x1.5 cable glands + internal thread for 2x ½"NPT cable protective pipe, cable outer diameter: $\varnothing 7$ ... $\varnothing 13$ mm (0.3 ... 0.5 inch), wire cross section: max. 1.5 mm <sup>2</sup> (AWG 15)
Electrical Protection	Class III
Housing Material	Plastic (PBT)
Sealing	FKM, On request: FFKM, EPDM
Mass (head unit)	1.5 kg (3.3 lb)
EX-Approvals	ATEX (ia): II 1/2 G Ex ia IIB T6...T5 Ga/Gb ICEX (ia): EX ia IIB T6...T5 Ga/Gb
Approvals	CE, UKCA, RoHS

<sup>1</sup> Under reference conditions and stabilized temperature

<sup>1</sup> Under reference conditions and stabilized temperature

### Probe specifications\*

Probe type	Max. Measuring Range	Dead-zone <sup>2</sup>		Process Connection	$\epsilon_r$ min.
		Upper (t) /lower (b) $\epsilon_r = 80$	Upper (t) /lower (b) $\epsilon_r = 2.4$		
Mono cable $\varnothing 4$ mm (0.15 in.)	6 m (19.6 feet)	300 / 20 mm (12 / 0.75 in.)	400 / 100 mm (16 / 4 in.)	1 in.	1.9
Mono rod $\varnothing 8$ mm (0.3 in.)	2 m (6.56 feet)	300 / 20 mm (12 / 0.75 in.)	400 / 100 mm (16 / 4 in.)	1 in.	1.9

\*The unmeasurable upper and lower part of the tank. The lower dead zone is extended by the length of the counterweight (cable versions only).

\* The unmeasurable upper and lower part of the tank. The lower dead zone is extended by the length of the counterweight (cable versions only).

<sup>2</sup> The unmeasurable upper and lower part of the tank, the lower dead-zone is extended with the length of the counterweight (cable version)

## Technical data of the probes

	Cable	Rod
Max. meas. dist.	24 m (80 feet)	3 m (10 feet)
Min. meas. Dist. ( $\epsilon_r = 80 / \epsilon_r = 2.4$ )	0.3 m / 0.4 m (1 feet / 1.3 feet)	
Minimal medium $\epsilon_r$	1.9	
Sensing space around the probe	Ø 600 mm (2 feet)	
Process connection	1" BSP, 1" NPT	
Probe material	1.4401 (316)	1.4571 (316 Ti)
Probe nominal Ø	4 mm (0.15 inch)	8 mm (0.3 inch)
Mass	0.12 kg/m (0.08 lb/ft)	0.4 kg/m (0.25 lb/ft)
Counterweight dimensions	Ø 25x100 mm (1x4 inch)	
Counterweight material	1.4571 (316 Ti)	

## Dimensions

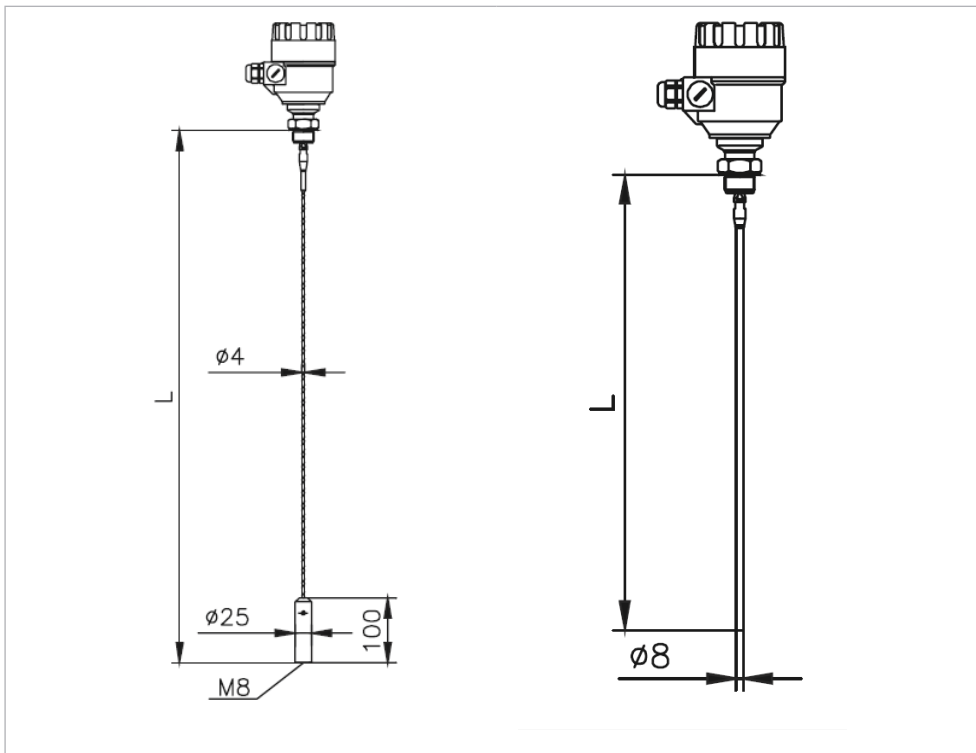

**Type 2291 Cable Version**  
L = 6 m (19.69 ft)

**Type 2291 Rod Version**  
L = 2 m (6.56 ft)

## Ordering Information

Mfr. Part No	Code	Description
2291-S-1DB1-6-R	159 300 190	LCD, PBT housing, 1" BSP, 6m cable Ø 4mm, SS316 Ti
2291-S-1DN1-6-R	159 300 191	LCD, PBT housing, 1" NPT, 6m cable Ø 4mm, SS316 Ti
2291-S-1DB1-2-D	159 300 192	LCD, PBT housing, 1" BSP, 2m rod Ø 8mm, SS316 Ti
2291-S-1DN1-2-D	159 300 193	LCD, PBT housing, 1" NPT, 2m rod Ø 8mm, SS316 Ti

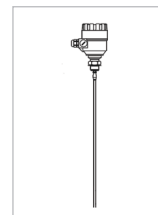

## Accessories

Mfr. Part No	Code	Description
	159 300 208	HART - USB Modem
3-8058-3	Special order	Wire-mount GF i-Go signal (4 to 20 mA /S <sup>3</sup> L) converter to connect 2290 to 9950 Smart Pro
3-8058-2	159 300 967	DIN rail mount GF i-Go (4 to 20 mA/S <sup>3</sup> L) converter to connect 2290 to 9950 SmartPro
3-9900-1P	159 001 695	9900 Transmitter - Panel Mount
3-9900-1	159 001 696	9900 Transmitter - Field Mount
3-9950-1	159 001 841	9950 Base Unit – Two Channel Multi-Parameter Inputs, Two 4 to 20 mA Outputs, Panel Mount, DC Power
3-9950-2	159 001 842	9950 Base Unit – Two Channel Multi-Parameter Inputs, Two 4 to 20 mA Outputs, Panel Mount, AC or DC Power

## Installation

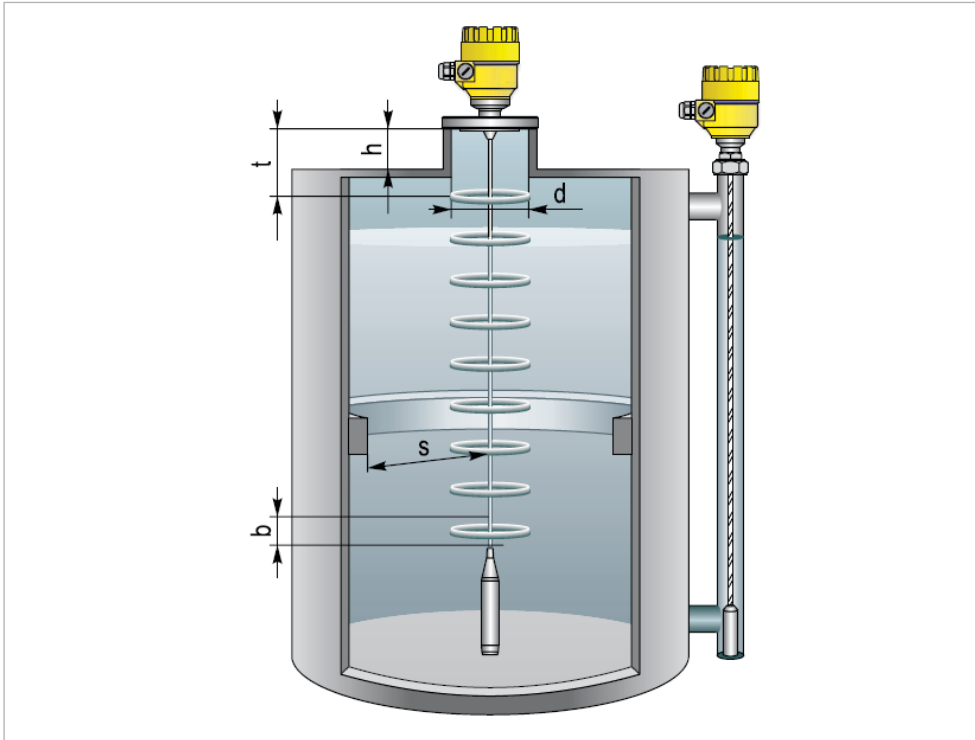

The probes can be removed from the head unit by the user.  
 $s$  = minimum distance from the internal disturbing objects.  
 Objects that are parallel to the probe do not disturb the measurement.  $s > 300$  mm (12 in.),  $h \leq d$ ,  $t$

## Wiring

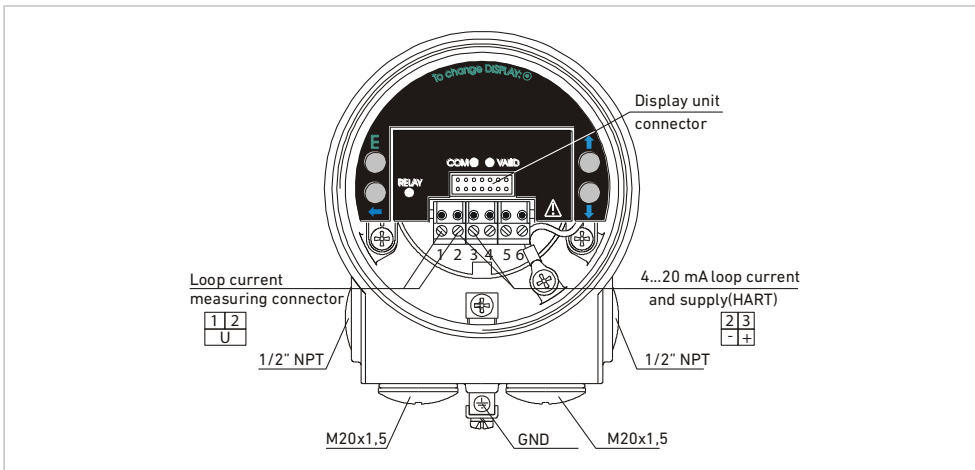

### To Power Supply / HART Modem

Standard wiring & connection of HART-Modem

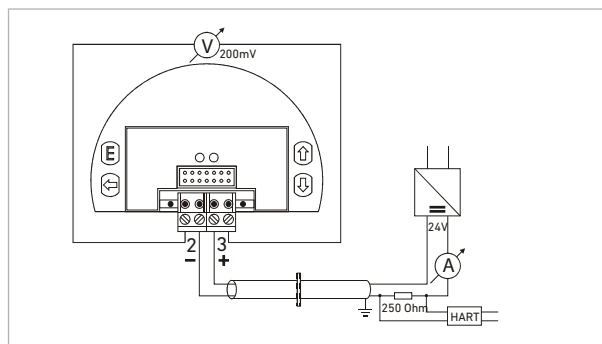

## Wiring in an EX-environment

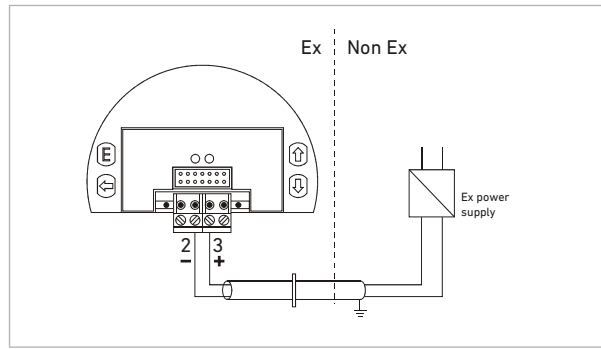

## To i-Go Converter - (S<sup>3</sup>L) / 4 to 20 mA

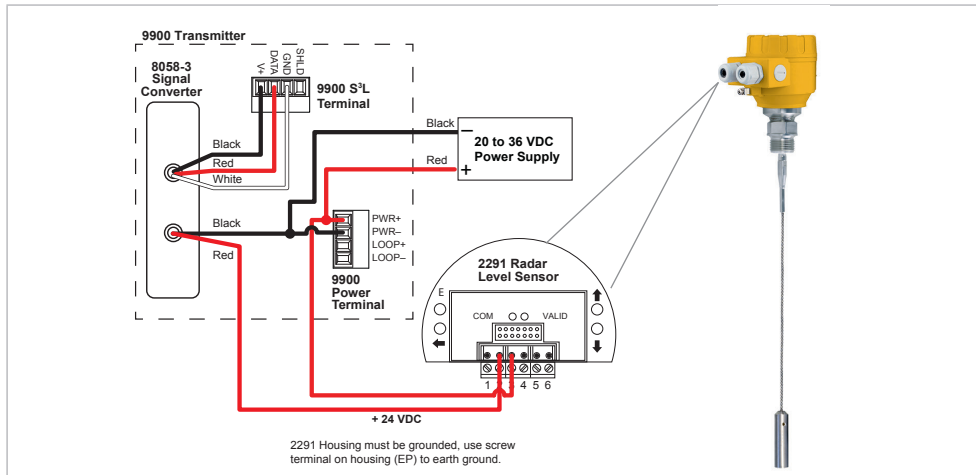

Pin No.	Assignment
1	mV Test, 10mV -> 1mA
2	4-20 mA current + supply (HART) any polarity
3	4-20 mA current + supply (HART) any polarity
4	Not Assigned
5	Not Assigned
6	Not Assigned

The information and technical data (altogether "Data") herein are not binding, unless explicitly confirmed in writing. The Data neither constitutes any expressed, implied or warranted characteristics, nor guaranteed properties or a guaranteed durability. All Data is subject to modification. The General Terms and Conditions of Sale of Georg Fischer Piping Systems apply.

10/2024-A

© Georg Fischer Piping Systems Ltd, 8201 Schaffhausen/Switzerland  
Tel. +41 52 631 11 11 • www.gfps.com • E-Mail: info.ps@georgfischer.com