

The tailor-made fitting for
non standard pipe diameters
DN40 - DN2200

ST-System



ST-System

Nowadays more and more water and gas pipe networks are extended or replaced by plastic piping systems. Due to this trend you have to deal with major differences in outside pipe diameters. In many cases this makes it impossible to use standard wide range fittings. Are you looking for a reliable and durable solution that can easily and efficiently connect all these different large diameter pipes? We have the answer for you. With the ST-System a tailor-made solution for all pipe outside diameters DN40 – DN2200 is provided.

Fittings for diameters up to and including DN2200

For non standard sizes

The ST-System is a dedicated system, specially developed for non standard sizes. Small or large, the fittings are suitable for all diameters between DN40 – DN2200. The ST-System can be used for various pipe materials such as PE, PVC, steel, asbestos cement and (ductile) cast iron.

Fields of application

- Water transport
- Water distribution
- Gas distribution
- Waste water
- Maintenance and repair
- Pumping stations
- Desalination installations
- Industrial applications



Your benefits

- **Tailor-made solution, suitable for any pipe outside diameter DN40 – DN2200**
- **Quick, safe and simple installation**
- **Durably corrosion protected by Resicoat® epoxy powder coating**
- **The very large insertion depth ensures easy installation and enables the fitting to be used as a disassembly piece**
- **Reusable**
- **Applicable for under and aboveground use**

Design at your request

The ST-System fittings are available from DN40 up to and including DN2200. We design the fitting you need at your request. This makes our system the ideal solution for projects. Whatever the challenge is when you are designing a project, we can offer the right solution. For tailor-made product design we kindly ask you to fill in our ST-System request form* or send us the following input data:

- Pipe material
- Outside diameter in mm of both pipe ends
- Working pressure
- SDR class (in case of plastic pipe)
- Flange drilling pattern (ANSI, PN10, PN16, JIS, BS)
- Medium

* Please contact your supplier to acquire the form.



Maintenance free connections





A reliable tailor-made solution

Easy to install

The ST-System series are available in the pressure classes PN10, PN16 and PN25. Thanks to the large insertion depth of 300mm, the installation of the ST-System fitting is very easy. This very long build in length is standard for all sizes and types. The fitting can also be used as a dismantling joint. Longer fittings or other configurations, are possible. Please contact us for more details.





Tailor-made solution

With the tailor-made solutions of the ST-System you can make your customized connection. This means that for all pipe outside diameters up to and including DN2200, every fitting can be tailor-made accurately to the millimeter. This provides you with a safe and reliable mechanical solution for big and non standard sizes. The ST-System can virtually be installed under all circumstances, without the use of special tools. These features result in time savings and stock reductions.



The system

Model

	Coupling	non restraint
	Reduced coupling	non restraint
	Flange adaptor	non restraint
	Reduced flange adaptor	non restraint

For other designs please contact us.



Long life expectancy

The fittings are protected from corrosion by Resicoat® epoxy powder coating. The ST-System is the perfect solution for under and aboveground applications in water and gas networks. The fittings are maintenance

free and have a technical life expectancy of 50 years. After all, you do want to guarantee an ongoing supply of water or gas to the end user and you want to prevent maintenance and repair.

+ Reliable and maintenance free connections at your request

Technical specifications

Specifications

Body	Steel ST-37-2, (S235JRG2) DIN/EN 17100.
Clamp ring	Steel ST-37-2, (S235JRG2) DIN/EN 17100.
Coating	Resicoat® epoxy powder coating, type RT 9000 R4, meets the requirements of ACS, Belgaqua, KTW, NSF Standard 61, WRAS, KIWA. Colour red (RAL 3003). Minimum layer thickness 250 micron.
Rubber gasket	Water and gas: NBR in accordance with EN 682. Optional: EPDM, FPM.
Bolts and nuts	Stainless steel A2 (AISI 304). Optional: stainless steel A4 (AISI 316).
Flange	Drilling pattern PN16 or PN10 in accordance with EN 1092-2. Others on request.
Working temperature	-10°C to +50°C.
Working pressure (PFA)	10, 16 and 25 bar water. 4 bar gas. Higher pressures on request.
Certificates	KTW, DGS, BSI, WRc.

DN (mm)		range (mm)	
DN40	- DN80	+ 2	- 1
DN100	- DN200	+ 2	- 1,5
DN250	- DN500	+ 4	- 3
DN600	- DN1100	+ 5	- 4
DN1200	- DN1600	+ 5,5	- 5
DN1600	- DN2200	on request	

Gasket design

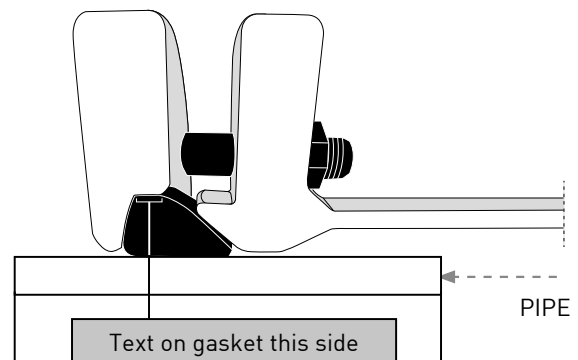

Insert stiffener

In case of connecting PE or PVC pipes, always install an insert stiffener.



Contact information

P.O. Box 290
8160 AG EPE
The Netherlands
T +31 578 678378
F +31 578 620848
www.waga.nl
waga.ps@georgfischer.com

The technical data are not binding and not expressly warranted characteristics of the goods. They are subject to change. Please consult our General Conditions of Supply.



WA2069/0516b/EN

© Georg Fischer Waga N.V.

2016, printed in the Netherlands

