

GF Piping Systems

+GF+

# Embrace the cold

COOL-FIT 2.0



# Confident insulation

**Efficient cooling processes are characterized by reliable installations and no maintenance times, zero system interruptions, and no energy loss. Choosing the right piping system can have a significant impact on these factors.**

Cooling systems for industrial cooling, process cooling, and air conditioning consume large amounts of energy to maintain a constant system temperature. Selecting the appropriate piping system to support the cooling circuit is of utmost importance for operators who aim for an efficient and reliable cooling process. What should you consider in particular?

The two most important factors are the material and the insulation. With conventional metal installations, the risk of condensation and subsequent corrosion is exceptionally high. This risk also occurs to systems that have been post-insulated. The insulation material can be damaged during installation. Small gaps between the piping system and the insulation layer can occur and allow ice formation due to condensation and subsequent corrosion. In addition, post-insulation requires an extra work step.



**Non-corrosive materials and vapor sealed insulation are of utmost importance for reliable and efficient piping systems in cooling applications.**



# Extreme reliability

The condensation and corrosion-free piping system for operations with no interruptions, zero maintenance, and highest efficiency.



## System integrity

The complete product portfolio consists of pre-insulated pipes, fittings, valves, flexible hoses, and all tools necessary for a safe and reliable installation.



## Efficient

High grade pre-insulation enhances energy efficiency (by 30%) with huge impact on costs and the planet's energy consumption.



## Reliable and safe

Maintenance-free operation for safe production with plastic construction providing a 25-year minimum lifespan.



#### **Corrosion-free**

100% corrosion-free and longer lasting than metal alternatives. No incrustation for reliable long-term efficient operation, ensures safe and reliable precision cooling.



#### **Fast and easy**

Simple jointing with electrofusion and system-specific tools.



#### **Lightweight**

60% less weight than steel pipes per meter, allowing single-person installs.



#### **Industry specific**

Small and large diameters specifically focused on indoor and outdoor applications.

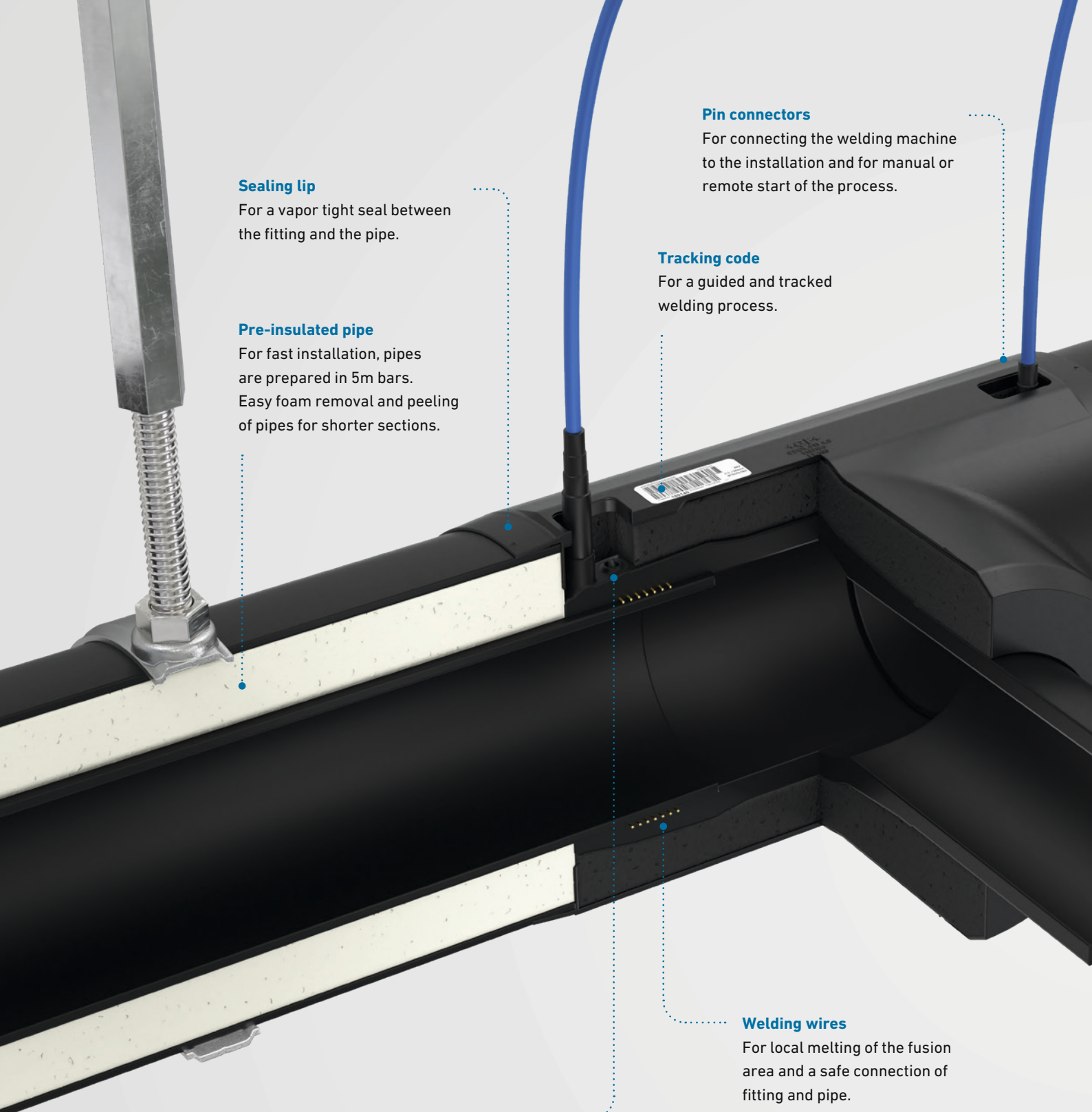

**Sealing lip**

For a vapor tight seal between the fitting and the pipe.

**Pre-insulated pipe**

For fast installation, pipes are prepared in 5m bars. Easy foam removal and peeling of pipes for shorter sections.

**Pin connectors**

For connecting the welding machine to the installation and for manual or remote start of the process.

**Tracking code**

For a guided and tracked welding process.

**Welding wires**

For local melting of the fusion area and a safe connection of fitting and pipe.

**Welding indicator**

For indication of a successful weld and haptic inspection after the welding process.

**Learn how to make the perfect weld in the COOL-FIT video tutorial.**

[gfps.com/cool-fit](https://gfps.com/cool-fit)



**Pre-insulated fitting**  
For fast and easy installation thanks to pre-insulation.  
No manual post-insulation required.

**Fixation**  
For securing against dislocation during installation with appropriate clamping tool.

## Electrofusion

# Confident installation

**One of the most significant benefits of COOL-FIT is the safe, simple, and fast installation by electrofusion. This jointing technology allows jointing within seconds.**

In electrofusion, wires built into the fitting are locally heated through electric current, which causes the melting and fusion of the surrounding material. This jointing technology ensures a secure and reliable connection. In combination

with a pre-insulated fitting with sealing lip, continuous insulation is also guaranteed. Once the components are assembled and secured against dislocation, the installation can be connected to the electrofusion unit. From there, the unit takes over and gives step-by-step instructions on the process. The fusion itself only takes seconds, and the welding indicator indicates its success. All welding data is stored on the welding device and is available for documenting the project.

# Extreme efficiency

**COOL-FIT leads the way when it comes to energy-efficient cooling and helps you to work in a more environmentally friendly and energy-efficient manner.**

The number of air conditioners in Europe will double by 2030, which leaves our industries with the challenge of rising energy demand. As a company that is active worldwide, it is GF Piping Systems' mission to show our commitment to sustainability by supporting our customers' success with innovative, energy-saving solutions making the collective global footprint more sustainable.

## **COOL-FIT environmental benefits**

- Saves at least 30% of energy compared to traditional cooling systems, drastically reducing operating costs and CO<sub>2</sub> emissions.
- Non-corrosive, with at least 25-year lifetime leading to additionally saved resources related to maintenance, repairs and replacements.
- Helps achieve relevant green building declarations like DGNB, BREEAM, and LEED.
- Free of HBCD, halogens and halogenated blowing agents. It contains no chlorinated paraffins and neither lead nor tin.
- Contains no other substance of very high concern according to the REACH criteria of the European Chemicals Agency or any candidate substance.
- Strict quality management (ISO 9001) and health and safety management (OHSAS 18001) during production. GF Piping Systems is certified according to ISO 14001 for its environmental management system.



## COOL-FIT for the environment

**COOL-FIT helps to reduce the environmental impact of your cooling- and refrigeration application.**

Compared to post-insulated metal systems, COOL-FIT is considerably more environmentally friendly and helps for operations to be more energy-efficient. For example: a cold store uses 1500 meters of piping to transport liquid for the cooling system. COOL-FIT releases about 100 tons carbon dioxide less than a metal system during production and operation. This saving is equivalent to a journey of 446'000 kilometers by car.

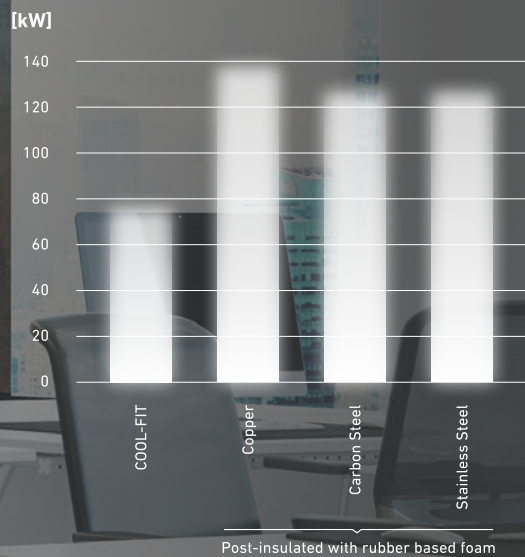

# 30%

energy savings compared to traditional cooling systems, drastically reducing operating costs and CO<sub>2</sub> emissions.

# Ultimate flexibility

To expand the COOL-FIT product portfolio, we worked with a team of experienced engineers and industry experts to deliver high-quality products and services that meet the ever-evolving needs of the global market. Our innovations strive for improving energy efficiency, reducing environmental impact, and optimizing system performance.

## Branch off with complete integrity

The COOL-FIT Weld-in port enhances the capabilities of the COOL-FIT piping system by simplifying the installation of additional sensors and branches across multiple pipe sizes.

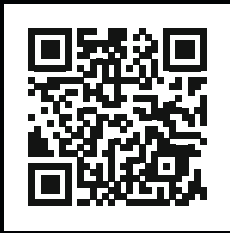

Learn more about the  
COOL-FIT Weld-in port  
[www.gfps.com/coolfit](http://www.gfps.com/coolfit)

### + Flexible planning

Easier project planning due to significantly increased flexibility with Weld-in port solution.

### + Efficient installation

Fast and easy installation in just 15 minutes, thereby reducing on-site work and labor costs.

### + Lower risk

Less failures with one fitting per branch size with a standardized install process, suitable for COOL-FIT pipes for d63 – d225.

### + Compact design

Designed with end customers mind, less space required. Ideal for new and retrofit projects.





## COOL-FIT 2.0 Push System

The COOL-FIT 2.0 Push System is an addition to the existing pre-insulated plastic piping system COOL-FIT 2.0 by extending the product range with smaller piping dimensions to reach the cooling unit.

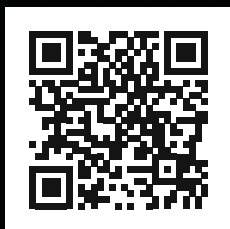

Learn more about the  
COOL-FIT 2.0 Push System  
[www.gfps.com/coolfit2](http://www.gfps.com/coolfit2)

### + One complete system

Complete pre-insulated piping solution for confident insulation, including pipes, fittings, valves, and tools.

### + Bridging big to small

Additional dimensions extend the range to reach the cooling unit for greater system performance and assurance.

### + Plug and play

Mechanical connections mean significantly less tools, easy handling, and faster installations.

### + Safe operation

Maintenance-free operation for 25 years thanks to unique material properties and safe jointing technology.

# Complete system integrity

With COOL-FIT, GF Piping Systems offers a unique, top-notch piping system solution, including pre-insulated pipes, fittings, valves, flexible hoses, and tools. The system is available in a standard version or with a higher fire classification (COOL-FIT 2.0F), to withstand even harsher conditions.

## Pre-insulated valves

GF Piping Systems' pre-insulated valves are an integral part of the COOL-FIT system and ensure an efficient cooling process. Pre-insulated valves ensure that the entire piping system is thoroughly insulated and perfectly sealed.



## Foam removal and peeling tools

GF Piping Systems takes the hassle out of foam removal and peeling. Easy to use foam removal tools ensure consistent peeling quality when preparing pipe surfaces. The tools are designed in such a way that pipes of different diameters can be prepared for installation in no time at all.

### Pre-insulated pipes

Easy to join and install, lightweight pre-insulated pipes help to minimize energy loss and reduce long-term running costs. Insulated with high-energy efficient foam, they are ideal for both new construction and retrofitting.

### Pre-insulated fittings

When creating branch lines, pre-insulated tee fittings make installation much easier. The fittings cover multiple dimension possibilities including various reductions.

### Bridging big to small dimensions

The COOL-FIT 2.0 Push System is an addition to the existing system COOL-FIT 2.0, by extending the product range with smaller piping dimensions to reach the cooling unit.

### COOL-FIT Weld-in port

The COOL-FIT Weld-in port simplifies the installation of additional sensors and branches across multiple pipe sizes.



## System specifications

# One entire system

A mainstay of the GF Piping Systems product range, COOL-FIT 2.0 is a plastic chilled-water piping system that is guaranteed not to corrode or be affected by the formation of condensation. The rapid installation time and high energy efficiency make this system a prime option for building owners, general contractors and planners as part of commercial/residential construction, data center design and process cooling applications.

## System properties

		COOL-FIT 2.0	COOL-FIT 2.0F
<b>Materials *</b>	Medium pipe	PE100	PE100
	Insulation	GF HE foam, halogen-free, closed-cell	GF HE foam, halogen-free, closed-cell
	Outer jacket	Pipe: HDPE, Fitting: GF-HE	Flame retardant – GF-FR
<b>Dimensions</b>		d32 mm (DN25) – d140 mm (DN125)	d32 mm (DN25) – d140 mm (DN125)
<b>Connection technology</b>		Electrofusion	Electrofusion
<b>Nominal pressure</b>		16 bar, SDR 11	16 bar, SDR 11
<b>Insulation</b>	Thermal conductivity $\lambda$ at 20°C	$\leq 0.022$ W/mK	$\leq 0.022$ W/mK
	Density	$\geq 70$ kg/m <sup>3</sup>	$\geq 70$ kg/m <sup>3</sup>
	Foam cell size	max. $\varnothing$ 0.5 mm	max. $\varnothing$ 0.5 mm
	Nominal thickness	22 mm	22 mm
<b>Temperature</b>	Medium	0 °C to +60 °C	0 °C to +60 °C
<b>Weight (without medium)</b>	Pipe d32 mm	1.12 kg/m	1.06 kg/m
	Pipe d110 mm	5.5 kg/m	5.39 kg/m
<b>Environment</b>	Resistance	Moisture- and vapor-tight	Moisture- and vapor-tight
	Ozone Depletion Potential (ODP)	Zero	Zero
<b>Standards</b>	Pipes & Fittings	EN ISO 15494	EN ISO 15494
	Threads	ISO 7 ISO 228	ISO 7 ISO 228
	Valves	EN ISO 16135 EN ISO 16136	EN ISO 16135 EN ISO 16136
<b>Fire classification</b>	EN 13501-1	E	B-s2, d0

\* All three materials are firmly bonded together.

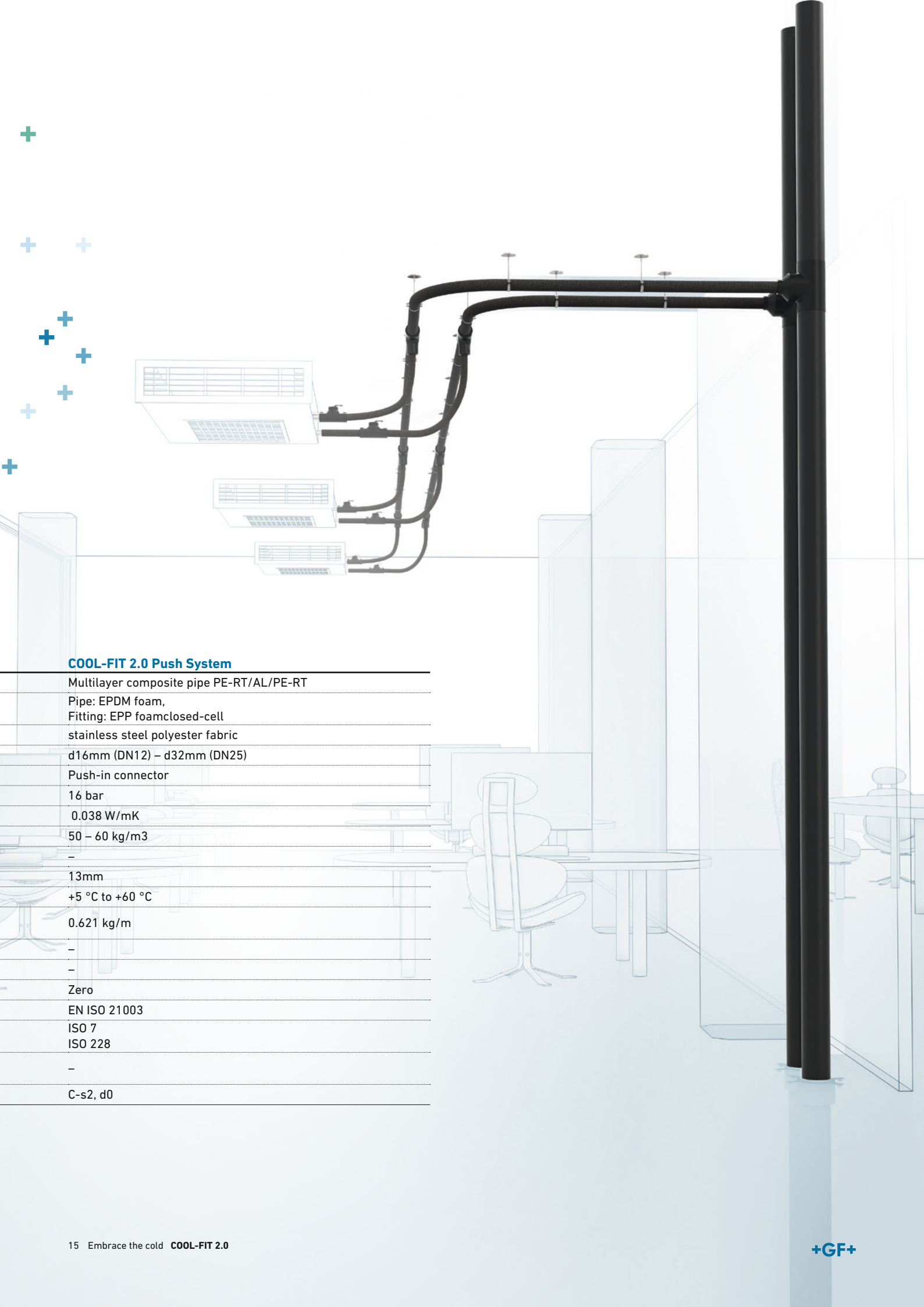

### COOL-FIT 2.0 Push System

Multilayer composite pipe PE-RT/AL/PE-RT

Pipe: EPDM foam,

Fitting: EPP foam closed-cell

stainless steel polyester fabric

d16mm (DN12) – d32mm (DN25)

Push-in connector

16 bar

0.038 W/mK

50 – 60 kg/m<sup>3</sup>

–

13mm

+5 °C to +60 °C

0.621 kg/m

–

–

Zero

EN ISO 21003

ISO 7

ISO 228

–

–

C-s2, d0

Applications

# Air conditioning and cooling applications

COOL-FIT 2.0 optimizes any air conditioning, process cooling and industrial air conditioning installation.





### Industrial air conditioning

An ambient work environment for the employees and stable temperatures for machinery help to sustain uninterrupted and efficient production processes.



### Cruise Ships

Corrosion-free air conditioning plays a vital role in onboard accommodation as it helps to have a healthy and pleasant atmosphere concerning temperature and humidity.



### Process Cooling

Production processes require stable temperatures for machinery. Reliable and maintenance-free cooling systems help to make production more efficient.



### Air Conditioning

Uninterrupted cooling processes and air conditioning ensure an ambient and comfortable environment at workplaces, residential buildings and hospitals.

# One partner from planning to commissioning

With Specialized Solutions, GF Piping Systems supports the design and installation of state of the art plastic piping systems, so that owners and planners can concentrate on their daily business without interruption. GF Piping Systems is present every step of the way, from providing planning support on new projects to testing the condition of old systems.

More information at  
[gfps.com/specialized-solutions](https://gfps.com/specialized-solutions)



## Custom Product Design and Prefabrication

Having your individual needs and application in focus, our customizing teams forge the solution that fits you best, developing custom-made parts to complete systems or special solutions produced in small series, individual consulting and off-site prefabrication. Through our global network of flexible locations, we offer a wide range of comprehensive solutions. Tailored innovation, inspired by you.



## Digital Libraries

The libraries cover three key areas for designing, creating, and maintaining a project: Building Information Modeling, the Plant Design Software, and the CAD Library helping you reduce costs and construction times while ensuring design accuracy and integrity. Reduce time and effort while ensuring design accuracy and integrity.





## Engineering

Increase the efficiency of your project with tailor-made analysis packages from GF Piping Systems. Minimize project risks by diminishing incorrect calculations or wrong material selection. Rely on GF's experience in fast project implementation and choose our durable, safe, and reliable piping systems delivery. Established knowledge, guiding you through.



## Cooling Tool-Box

The cooling calculation tool from GF Piping Systems supports the dimensioning and design of the secondary circuit. The cooling calculation tool includes calculation functions for expansion/ contraction, energy saving, surface temperatures, pipe dimensioning, pressure losses, CO2 footprint, and many more.

Use the online calculator  
[gfps.com/cooling-tools](https://gfps.com/cooling-tools)

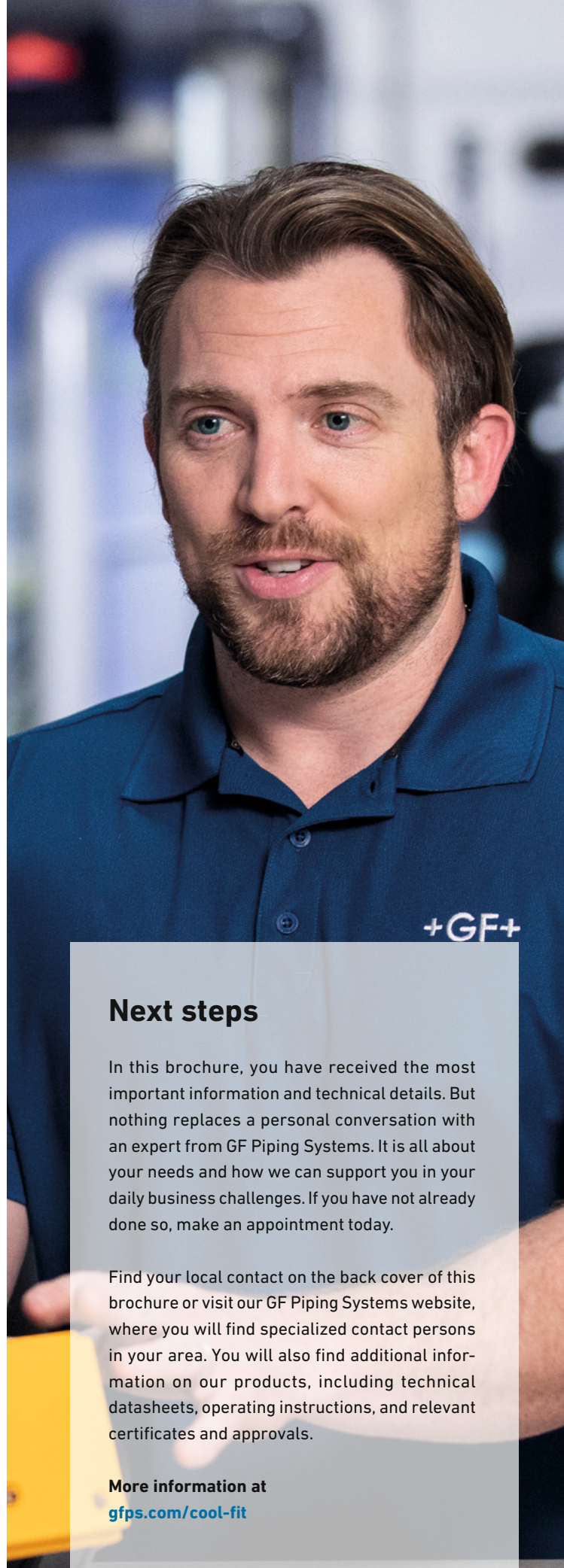

## Next steps

In this brochure, you have received the most important information and technical details. But nothing replaces a personal conversation with an expert from GF Piping Systems. It is all about your needs and how we can support you in your daily business challenges. If you have not already done so, make an appointment today.

Find your local contact on the back cover of this brochure or visit our GF Piping Systems website, where you will find specialized contact persons in your area. You will also find additional information on our products, including technical datasheets, operating instructions, and relevant certificates and approvals.

More information at  
[gfps.com/cool-fit](https://gfps.com/cool-fit)

Product range

# COOL-FIT 2.0



# Table of contents

COOL-FIT 2.0 Pipes and Fittings	22
COOL-FIT 2.0 Transition Fittings	27
COOL-FIT 2.0 Weld-in Port	43
COOL-FIT 2.0 Flexible Hoses	45
COOL-FIT 2.0 Valves	46
COOL-FIT 2.0 Accessories	60
COOL-FIT 2.0 Spare Parts	70
COOL-FIT 2.0 Push System Pipes and Fittings	74
COOL-FIT 2.0 Push System Valves	78
COOL-FIT 2.0 Push System Accessories	80
COOL-FIT 2.0 Push System Tools	83



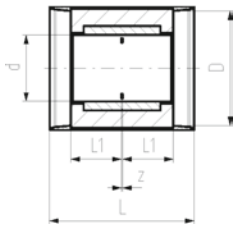

d (mm)	D (mm)	DN (mm)	SDR	PN (bar)	Code	Weight (kg)	L (mm)	L1 (mm)	z (mm)
63	110	50	11	16	<b>738 914 111</b>	0.237	137	48	3
75	125	65	11	16	<b>738 914 112</b>	0.339	152	55	3
90	140	80	11	16	<b>738 914 113</b>	0.476	166	62	4
110	160	100	11	16	<b>738 914 114</b>	0.778	188	72	4
140	200	125	11	16	<b>738 914 116</b>	1.097	210	84	3



A

### COOL-FIT 2.0 Elbow 90°

**Model:**

- Pre-insulated PE100 SDR11, metric
- Insulation made from GF HE foam
- Impact resistant. Color: black
- A: Electrofusion Fitting with integrated sealing lip, for a moisture-proof and vapour tight sealing

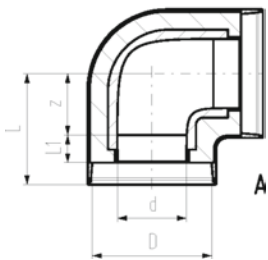

d (mm)	D (mm)	DN (mm)	SDR	PN (bar)	Code	Weight (kg)	L (mm)	L1 (mm)	Type	z (mm)
32	75	25	11	16	<b>738 104 108</b>	0.127	75	36	A	20
40	90	32	11	16	<b>738 104 109</b>	0.185	82	40	A	23
50	90	40	11	16	<b>738 104 110</b>	0.242	93	44	A	30
63	110	50	11	16	<b>738 104 111</b>	0.384	101	48	A	34
75	125	65	11	16	<b>738 104 112</b>	0.510	114	55	A	40
90	140	80	11	16	<b>738 104 113</b>	0.960	144	62	A	63
110	160	100	11	16	<b>738 104 114</b>	1.406	168	72	A	77
140	200	125	11	16	<b>738 104 166</b>	3.454	190	84	A	87



A

### COOL-FIT 2.0 Elbow 45°

**Model:**

- Pre-insulated PE100 SDR11, metric
- Insulation made from GF HE foam
- Impact resistant. Color: black
- A: Electrofusion Fitting with integrated sealing lip, for a moisture-proof and vapour tight sealing

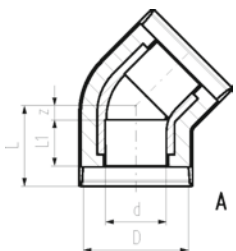

d (mm)	D (mm)	DN (mm)	SDR	PN (bar)	Code	Weight (kg)	L (mm)	L1 (mm)	Type	z (mm)
32	75	25	11	16	<b>738 154 108</b>	0.101	66	36	A	11
40	90	32	11	16	<b>738 154 109</b>	0.143	70	40	A	11
50	90	40	11	16	<b>738 154 110</b>	0.206	76	44	A	13
63	110	50	11	16	<b>738 154 111</b>	0.307	83	48	A	16
75	125	65	11	16	<b>738 154 112</b>	0.407	92	55	A	18
90	140	80	11	16	<b>738 154 113</b>	0.686	111	62	A	30
110	160	100	11	16	<b>738 154 114</b>	1.123	132	72	A	41
140	200	125	11	16	<b>738 154 166</b>	2.775	151	84	A	48



### COOL-FIT 2.0 Tee 90° equal

#### Model:

- Pre-insulated PE100 SDR11, metric
- Insulation made from GF HE foam
- Impact resistant. Color: black
- A: Electrofusion Fitting with integrated sealing lip, for a moisture-proof and vapour tight sealing

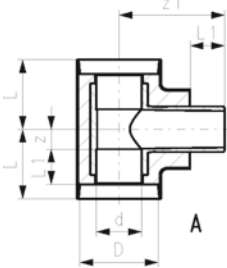

A

d (mm)	D (mm)	DN (mm)	SDR	PN (bar)	Code	Weight (kg)	L (mm)	L1 (mm)	Type	z (mm)	z1 (mm)
32	75	25	11	16	<b>738 204 108</b>	0.154	73	36	A	18	98.0
40	90	32	11	16	<b>738 204 109</b>	0.230	81	40	A	22	112.0
50	90	40	11	16	<b>738 204 110</b>	0.306	88	44	A	25	125.0
63	110	50	11	16	<b>738 204 111</b>	0.492	97	48	A	30	147.0
75	125	65	11	16	<b>738 204 112</b>	0.673	110	55	A	36	140.0
90	140	80	11	16	<b>738 204 113</b>	1.022	124	62	A	43	161.0
110	160	100	11	16	<b>738 204 114</b>	1.751	148	72	A	57	184.0
140	200	125	11	16	<b>738 204 166</b>	4.390	169	84	A	66	257.3



### COOL-FIT 2.0 Tee 90° reduced

#### Model:

- Pre-insulated PE100 SDR11, metric
- Insulation made from GF HE foam
- Impact resistant. Color: black
- A: Electrofusion Fitting with integrated sealing lip, for a moisture-proof and vapour tight sealing. Branch with free pipe end.

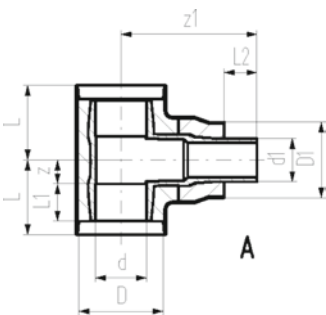

A

d (mm)	d1 (mm)	D (mm)	D1 (mm)	DN (mm)	SDR	PN (bar)	Code	Weight (kg)
75	63	125	110	65	11	16	<b>738 204 218</b>	0.746
90	63	140	110	80	11	16	<b>738 204 222</b>	1.096
90	75	140	125	80	11	16	<b>738 204 223</b>	1.133
110	63	160	110	100	11	16	<b>738 204 227</b>	1.746
110	75	160	125	100	11	16	<b>738 204 228</b>	1.782
110	90	160	140	100	11	16	<b>738 204 229</b>	1.848
140	63	110	110	125	11	16	<b>738 204 240</b>	3.685
140	75	125	125	125	11	16	<b>738 204 241</b>	3.724
140	90	140	140	125	11	16	<b>738 204 242</b>	3.807
140	110	160	160	125	11	16	<b>738 204 243</b>	3.990

d (mm)	d1 (mm)	L (mm)	L1 (mm)	L2 (mm)	Type	z (mm)	z1 (mm)
75	63	110	55	48	A	36	200
90	63	124	62	48	A	42	227
90	75	124	62	55	A	42	227
110	63	148	72	48	A	57	245
110	75	148	72	55	A	57	245
110	90	148	72	62	A	57	245
140	63	169	84	48	A	66	221
140	75	169	84	55	A	66	231
140	90	169	84	62	A	66	234
140	110	169	84	72	A	66	243





### COOL-FIT 2.0 Tee 90° reduced short

**Model:**

- Pre-insulated PE100 SDR11, metric
- Insulation made from GF HE foam
- Impact resistant. Color: black
- A: Electrofusion Fitting with integrated sealing lip, for a water and vapour tight sealing
- Space-optimized branch: sealing lip of Fitting Typ A that joins to the branch, needs to be cut and adhesive ring be use

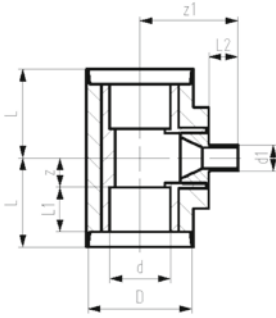

d (mm)	d1 (mm)	D (mm)	DN (mm)	SDR	PN (bar)	Code	Weight (kg)	L (mm)	L1 (mm)	L2 (mm)	Type	z (mm)	z1 (mm)
40	32	90	32	11	16	<b>738 204 506</b>	0.250	81	40	36	A	22	108
50	32	90	40	11	16	<b>738 204 509</b>	0.340	88	44	36	A	25	117
63	32	110	50	11	16	<b>738 204 512</b>	0.550	97	48	36	A	30	135
75	32	125	65	11	16	<b>738 204 515</b>	0.750	110	55	36	A	36	121
90	32	140	80	11	16	<b>738 204 519</b>	1.150	124	62	36	A	43	135
110	32	160	100	11	16	<b>738 204 524</b>	2.000	148	72	36	A	57	148

### COOL-FIT 2.0 Reducer

**Model:**

- Pre-insulated PE100 SDR11, metric
- Insulation made from GF HE foam
- Impact resistant. Color: black
- A: Electrofusion Fitting with integrated sealing lip, for a moisture-proof and vapour tight sealing
- B: Spigot Fitting with free end (separate electrofusion fitting needed for joining)

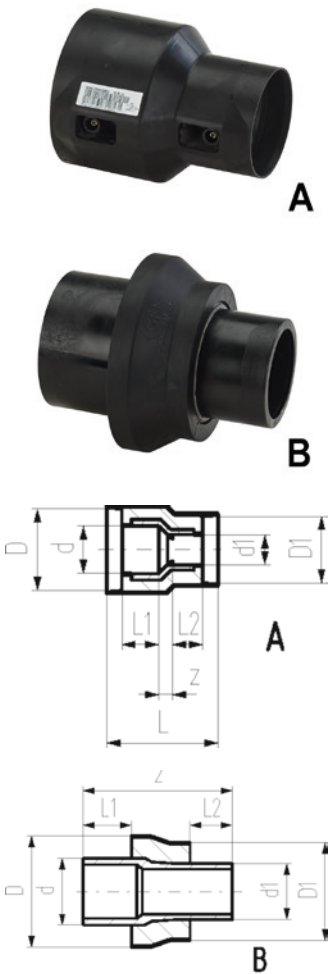

d (mm)	d1 (mm)	D (mm)	D1 (mm)	DN (mm)	SDR	PN (bar)	Code	Weight (kg)	L (mm)	L1 (mm)	L2 (mm)	Type	z (mm)
40	32	90	75	32	11	16	<b>738 904 206</b>	0.125	131	40	36	A	17
50	32	90	75	40	11	16	<b>738 904 209</b>	0.154	139	44	36	A	21
50	40	90	90	40	11	16	<b>738 904 210</b>	0.153	137	44	40	A	15
63	32	110	75	50	11	16	<b>738 904 212</b>	0.198	148	48	36	A	26
63	40	110	90	50	11	16	<b>738 904 213</b>	0.221	147	48	40	A	21
63	50	110	90	50	11	16	<b>738 904 214</b>	0.219	147	48	44	A	17
90	63	140	110	80	11	16	<b>738 904 222</b>	0.464	187	62	48	A	39
110	90	160	140	100	11	16	<b>738 904 229</b>	0.799	214	72	62	A	42
75	63	125	110	65	11	16	<b>738 904 318</b>	0.244		55	48	B	170
90	63	140	110	80	11	16	<b>738 904 322</b>	0.360		62	48	B	190
90	75	140	125	80	11	16	<b>738 904 323</b>	0.395		62	55	B	190
110	63	160	110	100	11	16	<b>738 904 327</b>	0.523		72	48	B	205
110	75	160	125	100	11	16	<b>738 904 328</b>	0.553		72	55	B	205
110	90	160	140	100	11	16	<b>738 904 329</b>	0.599		72	62	B	205
140	63	200	110	125	11	16	<b>738 904 340</b>	0.917		84	48	B	225
140	75	200	125	125	11	16	<b>738 904 341</b>	0.997		84	55	B	237
140	90	200	140	125	11	16	<b>738 904 342</b>	1.039		84	62	B	238
140	110	200	160	125	11	16	<b>738 904 343</b>	1.051		84	72	B	233



### COOL-FIT 2.0 Reducer short

#### Model:

- Spigot fitting PE100 SDR11, metric with free end
- Space-optimized branch: sealing lip of Fitting Typ A that joins to the branch, needs to be cut and adhesive ring be use

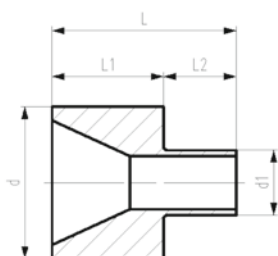

d (mm)	d1 (mm)	DN (mm)	SDR	PN (bar)	Code	Weight (kg)	L (mm)	L1 (mm)	L2 (mm)
40	32	32	11	16	<b>738 900 506</b>	0.030	76	40	36
50	32	40	11	16	<b>738 900 509</b>	0.060	80	44	36
50	40	40	11	16	<b>738 900 510</b>	0.060	84	44	40
63	32	50	11	16	<b>738 900 512</b>	0.100	84	48	36
63	40	50	11	16	<b>738 900 513</b>	0.100	88	48	40
63	50	50	11	16	<b>738 900 514</b>	0.100	92	48	44
75	32	65	11	16	<b>738 900 515</b>	0.170	91	55	36
90	32	80	11	16	<b>738 900 519</b>	0.280	98	62	36
110	32	100	11	16	<b>738 900 524</b>	0.500	108	72	36



### COOL-FIT 2.0 Installation fitting type 313 Rp

#### Model:

- Pre-insulated PE100 SDR11, metric
- Insulation made from GF HE foam
- Impact resistant. Color: black
- With threaded branch for sensors (i.e temperature, pressure)
- A: Electrofusion Fitting with integrated sealing lip, for a moisture-proof and vapour tight sealing

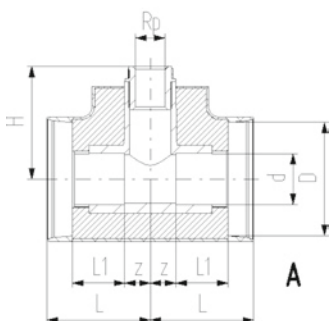

d (mm)	D (mm)	Thread Size (inch)	DN (mm)	SDR	PN (bar)	Code	Weight (kg)	H (mm)	L (mm)	L1 (mm)	Type	z (mm)	
32	75	Rp	½	25	11	16	<b>738 313 408</b>	0.138	75	73	36	A	16
40	90	Rp	½	32	11	16	<b>738 313 409</b>	0.216	85	81	40	A	21
40	90	Rp	¾	32	11	16	<b>738 313 459</b>	0.216	88	81	40	A	21
50	90	Rp	½	40	11	16	<b>738 313 410</b>	0.308	94	88	44	A	24
50	90	Rp	¾	40	11	16	<b>738 313 460</b>	0.307	97	88	44	A	24
63	110	Rp	½	50	11	16	<b>738 313 411</b>	0.493	113	97	48	A	29
63	110	Rp	¾	50	11	16	<b>738 313 461</b>	0.492	116	97	48	A	29
75	125	Rp	½	65	11	16	<b>738 313 412</b>	0.678	99	110	55	A	35
75	125	Rp	¾	65	11	16	<b>738 313 462</b>	0.677	102	110	55	A	35
90	140	Rp	½	80	11	16	<b>738 313 413</b>	1.025	113	123	62	A	42
90	140	Rp	¾	80	11	16	<b>738 313 463</b>	1.023	116	123	62	A	42
110	160	Rp	½	100	11	16	<b>738 313 414</b>	1.765	128	148	72	A	56
110	160	Rp	¾	100	11	16	<b>738 313 464</b>	1.763	131	148	72	A	56
140	200	Rp	½	125	11	16	<b>738 313 436</b>	3.747	190	169	84	A	66
140	200	Rp	¾	125	11	16	<b>738 313 486</b>	3.747	190	169	84	A	66

# COOL-FIT 2.0 Transition Fittings

## COOL-FIT 2.0 Transition Tee90° PE/brass With female thread Rp

### Model:

- Pre-insulated, PE100, SDR11, metric
- Brass CuZn40Pb2 with female thread Rp
- Insulation made from GF HE foam
- Impact resistant. Color: black
- A: Electrofusion Fitting with integrated sealing lip, for a water and vapour tight sealing
- B: Spigot Fitting with free end (separate electrofusion fitting needed for joining)



A



B

d (mm)	D (mm)	Thread Size (inch)	DN (mm)	SDR	PN (bar)	Code	Weight (kg)	L (mm)	L1 (mm)	H (mm)	Type	z (mm)
63	110	Rp 2	50	11	16	<b>738 954 061</b>	1.700	97	48	212	A	29
75	125	Rp 2	65	11	16	<b>738 954 062</b>	1.900	110	55	193	A	36
90	140	Rp 2	80	11	16	<b>738 954 063</b>	2.300	124	62	210	A	43
110	160	Rp 2	100	11	16	<b>738 954 064</b>	3.100	148	72	223	A	57
140	200	Rp 2	125	11	16	<b>738 954 066</b>	4.700		84	316	B	447

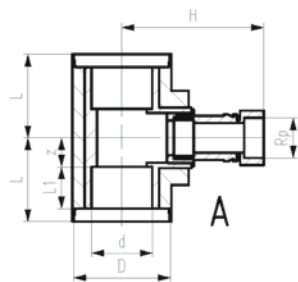

A

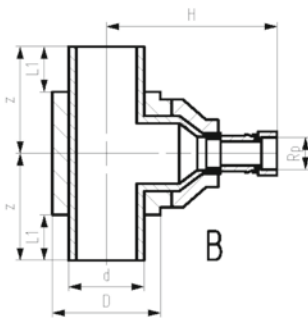

B



### COOL-FIT 2.0 Adaptor fitting PE/stainless steel With male thread R

#### Model:

- Spigot fitting PE100 SDR11, metric with free end
- Stainless steel 1.4404 / 316L with male thread R
- Gasket: O-ring EPDM
- Including Insulation made from NBR foam

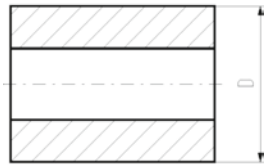
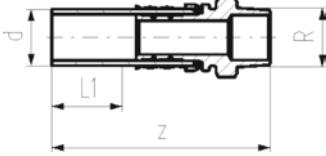

d (mm)	D (mm)	Thread	Size (inch)	DN (mm)	SDR	PN (bar)	Code	Weight (kg)	L1 (mm)	z (mm)
32	70	R	½	25	11	16	<b>738 944 508</b>	0.194	36	130
32	70	R	¾	25	11	16	<b>738 944 518</b>	0.202	36	134
32	70	R	1	25	11	16	<b>738 944 528</b>	0.211	36	134
40	78	R	1 ¼	32	11	16	<b>738 944 509</b>	0.595	40	156
50	88	R	1 ½	40	11	16	<b>738 944 510</b>	0.954	44	168
63	101	R	2	50	11	16	<b>738 944 511</b>	1.381	48	179



### COOL-FIT 2.0 Adaptor fitting PE/stainless steel With female thread Rp

#### Model:

- Spigot fitting PE100 SDR11, metric with free end
- Stainless steel 1.4404 / 316L with femal thread Rp
- Gasket: O-ring EPDM
- Including Insulation made from NBR foam

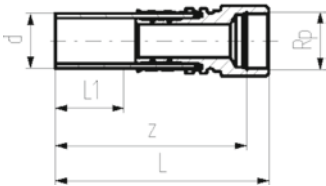

d (mm)	D (mm)	Thread	Size (inch)	DN (mm)	SDR	PN (bar)	Code	Weight (kg)	L (mm)	L1 (mm)	z (mm)
32	70	Rp	½	25	11	16	<b>738 944 008</b>	0.201	132	36	118
32	70	Rp	¾	25	11	16	<b>738 944 018</b>	0.226	132	36	116
32	70	Rp	1	25	11	16	<b>738 944 028</b>	0.251	132	36	115
40	78	Rp	1 ¼	32	11	16	<b>738 944 009</b>	0.626	157	40	141
50	88	Rp	1 ½	40	11	16	<b>738 944 010</b>	0.670	150	44	128
63	101	Rp	2	50	11	16	<b>738 944 011</b>	1.170	164	48	140



### COOL-FIT 2.0 Adaptor fitting PE/stainless steel With loose union nut G

#### Model:

- Spigot fitting PE100 SDR11, metric with free end
- Stainless steel 1.4404 / 316L with female thread G
- Including flat seal EPDM
- Including Insulation made from NBR foam

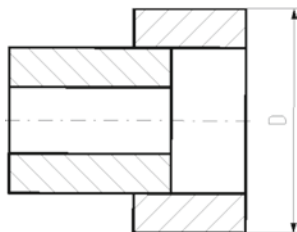
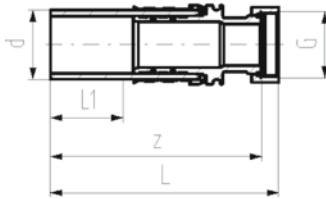

d (mm)	D (mm)	Thread	Size (inch)	DN (mm)	SDR	PN (bar)	Code	Weight (kg)	L (mm)	L1 (mm)	z (mm)
32	70	G	½	25	11	16	<b>738 944 308</b>	0.204	135	36	126
32	70	G	¾	25	11	16	<b>738 944 318</b>	0.219	135	36	129
32	70	G	1	25	11	16	<b>738 944 328</b>	0.317	135	36	129
40	78	G	1 ¼	32	11	16	<b>738 944 309</b>	0.538	155	40	148
40	116	G	1 ½	32	11	16	<b>738 944 319</b>	0.615	157	40	148
50	88	G	1 ½	40	11	16	<b>738 944 310</b>	0.758	164	44	154
63	101	G	2	50	11	16	<b>738 944 311</b>	1.237	186	48	170



### COOL-FIT 2.0 Adaptor fitting PE/brass With male thread R

#### Model:

- Spigot fitting PE100 SDR11, metric with free end
- Brass CuZn40Pb2 with male thread R
- Gasket: O-ring EPDM
- Including Insulation made from NBR foam

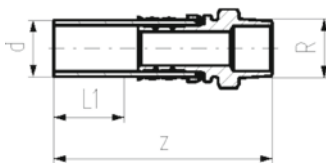

d (mm)	D (mm)	Thread	Size (inch)	DN (mm)	SDR	PN (bar)	Code	Weight (kg)	L1 (mm)	z (mm)
32	70	R	½	25	11	16	<b>738 954 508</b>	0.203	36	130
32	70	R	¾	25	11	16	<b>738 954 518</b>	0.211	36	134
32	70	R	1	25	11	16	<b>738 954 528</b>	0.221	36	134
40	78	R	1 ¼	32	11	16	<b>738 954 509</b>	0.631	40	156
50	88	R	1 ½	40	11	16	<b>738 954 510</b>	1.013	44	168
63	101	R	2	50	11	16	<b>738 954 511</b>	1.467	48	179



### COOL-FIT 2.0 Adaptor fitting PE/brass With female thread Rp

#### Model:

- Spigot fitting PE100 SDR11, metric with free end
- Brass CuZn40Pb2 with female tread Rp
- Gasket: O-ring EPDM
- Including Insulation made from NBR foam

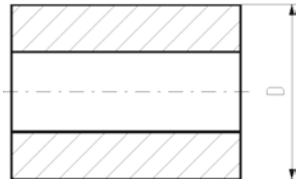
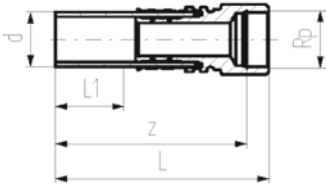

d (mm)	D (mm)	Thread	Size (inch)	DN (mm)	SDR	PN (bar)	Code	Weight (kg)	L (mm)	L1 (mm)	z (mm)
32	70	Rp	½	25	11	16	<b>738 954 008</b>	0.210	132	36	118
32	70	Rp	¾	25	11	16	<b>738 954 018</b>	0.237	132	36	116
32	70	Rp	1	25	11	16	<b>738 954 028</b>	0.264	132	36	115
40	78	Rp	1 ¼	32	11	16	<b>738 954 009</b>	0.667	157	40	141
50	88	Rp	1 ½	40	11	16	<b>738 954 010</b>	0.713	150	44	128
63	101	Rp	2	50	11	16	<b>738 954 011</b>	1.246	164	48	140



### COOL-FIT 2.0 Adaptor fitting PE/brass With loose union nut G

#### Model:

- Spigot fitting PE100 SDR11, metric with free end
- Brass CuZn40Pb2 with female thread G
- Including flat seal EPDM
- Including Insulation made from NBR foam

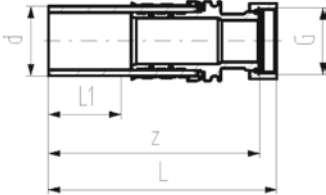

d (mm)	D (mm)	Thread	Size (inch)	DN (mm)	SDR	PN (bar)	Code	Weight (kg)	L (mm)	L1 (mm)	z (mm)
32	70	G	¾	25	11	16	<b>738 954 318</b>	0.224	135	36	126
32	70	G	1	25	11	16	<b>738 954 328</b>	0.263	135	36	129
32	108	G	1 ¼	25	11	16	<b>738 954 338</b>	0.335	137	36	129
40	78	G	1 ¼	32	11	16	<b>738 954 309</b>	0.569	155	40	148
40	116	G	1 ½	32	11	16	<b>738 954 319</b>	0.650	157	40	148
50	88	G	1 ½	40	11	16	<b>738 954 310</b>	0.801	164	44	154
63	101	G	2	50	11	16	<b>738 954 311</b>	1.310	186	48	170

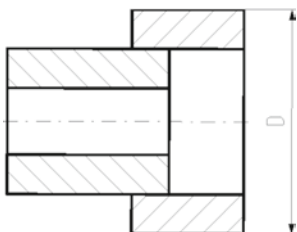



### COOL-FIT 2.0 Adaptor union PE/stainless steel With male thread R

#### Model:

- Union bush: Spigot fitting PE100 SDR11, metric with free end
- Union End: Stainless steel 1.4404 / 316L with male thread R
- Gasket: O-ring EPDM No. 748 410 008-011
- Union Nut: PEGF25
- Including Insulation made from NBR foam

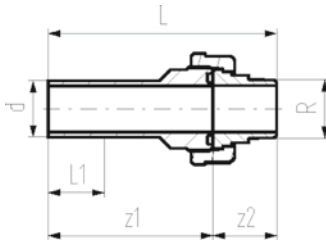

d (mm)	D (mm)	Thread	Size (inch)	DN (mm)	SDR	PN (bar)	Code	Weight (kg)	L (mm)	L1 (mm)	z1 (mm)	z2 (mm)
32	108	R	1	25	11	16	<b>738 544 708</b>	0.310	147	36	107	40
40	116	R	1 ¼	32	11	16	<b>738 544 709</b>	0.538	163	40	117	46
50	126	R	1 ½	40	11	16	<b>738 544 710</b>	0.660	172	44	124	48
63	139	R	2	50	11	16	<b>738 544 711</b>	1.073	191	48	136	55

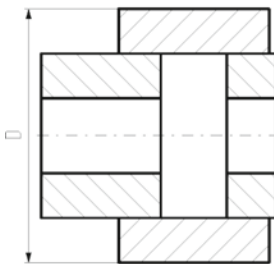

### COOL-FIT 2.0 Adaptor union PE/stainless steel With female thread Rp

#### Model:

- Union bush: Spigot fitting PE100 SDR11, metric with free end
- Union End: Stainless steel 1.4404 / 316L with female thread Rp
- Gasket: O-ring EPDM No. 748 410 008-011
- Union Nut: PEGF25
- Including Insulation made from NBR foam

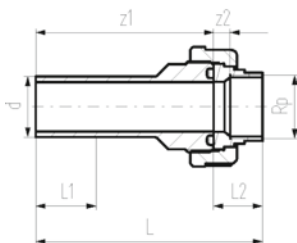

d (mm)	D (mm)	Thread	Size (inch)	DN (mm)	SDR	PN (bar)	Code	Weight (kg)	L (mm)	L1 (mm)	L2 (mm)	z1 (mm)	z2 (mm)
32	108	Rp	1	25	11	16	<b>738 544 208</b>	0.270	136	36	29	107	10
40	116	Rp	1 ¼	32	11	16	<b>738 544 209</b>	0.433	150	40	33	118	11
50	126	Rp	1 ½	40	11	16	<b>738 544 210</b>	0.587	158	44	34	124	13
63	139	Rp	2	50	11	16	<b>738 544 211</b>	0.883	175	48	39	136	14

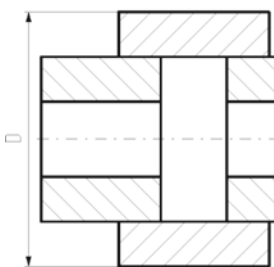



### COOL-FIT 2.0 Union PE/PE

#### Model:

- Union bush: Spigot fitting PE100 SDR11, metric with free end
- Union End: Spigot fitting PE100 SDR11, metric with free end
- Gasket: O-ring EPDM No. 748 410 008-014
- Union Nut: PEGF25
- Including Insulation made from NBR foam

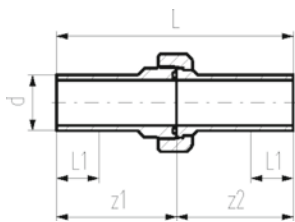

d (mm)	D (mm)	DN (mm)	SDR	PN (bar)	Code	L (mm)	L1 (mm)	z1 (mm)	z2 (mm)
32	108	25	11	16	<b>738 514 608</b>	211	36	107	104
40	116	32	11	16	<b>738 514 609</b>	234	40	118	117
50	126	40	11	16	<b>738 514 610</b>	247	44	124	123
63	139	50	11	16	<b>738 514 611</b>	268	48	136	132
75	151	65	11	10	<b>738 514 612</b>	303	55	154	149
90	166	80	11	10	<b>738 514 613</b>	293	62	149	144
110	186	100	11	10	<b>738 514 614</b>	321	72	162	159

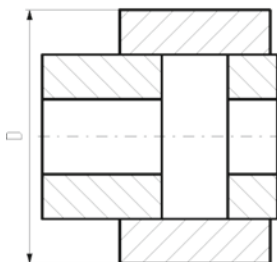

### COOL-FIT 2.0 Adaptor Union PE/ABS

#### Model:

- Union bush: ABS Solvent cement socket
- Union End: Spigot fitting PE100 SDR11, metric with free end
- Gasket: O-ring EPDM No. 748 410 008-014
- Union Nut: ABS
- Including Insulation made from NBR foam

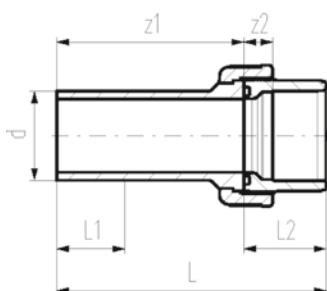

d (mm)	D (mm)	DN (mm)	SDR	PN (bar)	Code	Weight (kg)	L (mm)	L1 (mm)	L2 (mm)	z1 (mm)	z2 (mm)
32	108	25	11	10	<b>738 514 708</b>	0.117	137	36	33	104	11
40	116	32	11	10	<b>738 514 709</b>	0.196	156	40	39	117	13
50	126	40	11	10	<b>738 514 710</b>	0.268	169	44	46	123	15
63	139	50	11	10	<b>738 514 711</b>	0.427	190	48	58	132	21
75	151	65	11	10	<b>738 514 712</b>	0.730	211	55	62	149	18
90	166	80	11	10	<b>738 514 713</b>	0.974	215	62	69	146	19
110	186	100	11	10	<b>738 514 714</b>	1.478	235	72	72	163	11

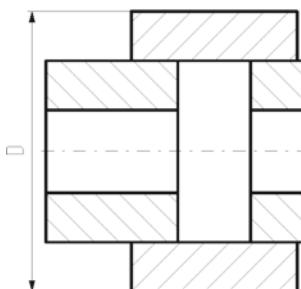



### COOL-FIT 2.0 Adaptor fitting PE/iFIT



#### Model:

- Spigot fitting PE100 SDR11, metric with free end
- iFIT module stainless steel 1.4404 / 316L
- Including insulation half shells

d	D	d1	DN	SDR	PN	Code	Weight	L	L1	L2
(mm)	(mm)	(mm)	(mm)		(bar)		(kg)	(mm)	(mm)	(mm)
32	70	25-32	25	11	10	<b>738 944 108</b>	0.229	132	36	80

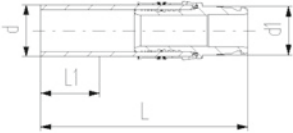

### COOL-FIT 2.0 Adaptor fitting PE/Sanipex MT



#### Model:

- Spigot fitting PE100 SDR11, metric with free end
- Sanipex MT adaptor brass CuZn40Pb2
- Including Insulation made from NBR foam

d	D	DN	PN	SDR	d1	Code	Weight	L	L1	L2	z
(mm)	(mm)	(mm)	(bar)		(mm)		(kg)	(mm)	(mm)	(mm)	(mm)
32	86	25	10	11	32	<b>738 954 118</b>	0.441	174	36	101	135

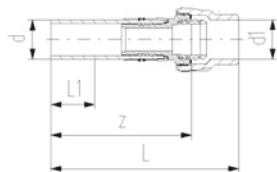



**COOL-FIT 2.0/4.0 Adaptor fitting PE/brass**  
With male thread R



**Model:**

- Spigot fitting PE100 SDR11, metric with free end
- Brass CuZn40Pb2 with male thread R
- Gasket: O-ring EPDM

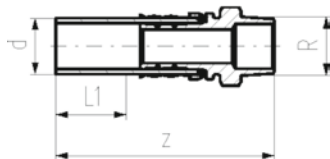

d (mm)	Thread	Size (inch)	DN (mm)	SDR	PN (bar)	Code	Weight (kg)	L1 (mm)	z (mm)
32	R	½	25	11	16	<b>738 950 508</b>	0.188	36	130
32	R	¾	25	11	16	<b>738 950 518</b>	0.196	36	134
32	R	1	25	11	16	<b>738 950 528</b>	0.206	36	134
40	R	1 ¼	32	11	16	<b>738 950 519</b>	0.608	40	156
50	R	1 ½	40	11	16	<b>738 950 510</b>	0.986	44	168
63	R	2	50	11	16	<b>738 950 511</b>	1.433	48	179

**COOL-FIT 2.0/4.0 Adaptor fitting PE/brass**  
With female thread Rp



**Model:**

- Spigot fitting PE100 SDR11, metric with free end
- Brass CuZn40Pb2 with female tread Rp
- Gasket: O-ring EPDM

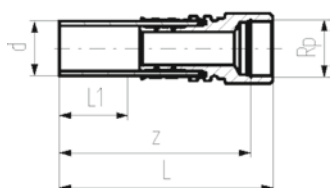

d (mm)	Thread	Size (inch)	DN (mm)	SDR	PN (bar)	Code	Weight (kg)	L (mm)	L1 (mm)	z (mm)
32	Rp	½	25	11	16	<b>738 950 008</b>	0.192	132	36	118
32	Rp	¾	25	11	16	<b>738 950 018</b>	0.219	132	36	116
32	Rp	1	25	11	16	<b>738 950 028</b>	0.246	132	36	115
40	Rp	1 ¼	32	11	16	<b>738 950 019</b>	0.641	157	40	141
50	Rp	1 ½	40	11	16	<b>738 950 010</b>	0.684	150	44	128
63	Rp	2	50	11	16	<b>738 950 011</b>	1.209	164	48	140

**COOL-FIT 2.0/4.0 Adaptor fitting PE/brass**  
With loose union nut G



**Model:**

- Spigot fitting PE100 SDR11, metric with free end
- Brass CuZn40Pb2 with loose union nut G
- Including flat seal EPDM

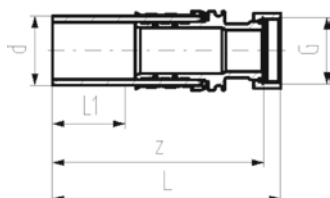

d (mm)	Thread	Size (inch)	DN (mm)	SDR	PN (bar)	Code	Weight (kg)	L (mm)	L1 (mm)	z (mm)
32	G	¾	25	11	16	<b>738 950 318</b>	0.206	135	36	129
32	G	1	25	11	16	<b>738 950 328</b>	0.244	135	36	129
32	G	1 ¼	25	11	16	<b>738 950 338</b>	0.301	137	36	131
40	G	1 ¼	32	11	16	<b>738 950 309</b>	0.543	155	40	148
40	G	1 ½	32	11	16	<b>738 950 319</b>	0.607	157	40	148
50	G	1 ½	40	11	16	<b>738 950 310</b>	0.769	164	44	154
63	G	2	50	11	16	<b>738 950 311</b>	1.268	186	48	170

### COOL-FIT 2.0/4.0 Adaptor union PE/stainless steel With male thread R

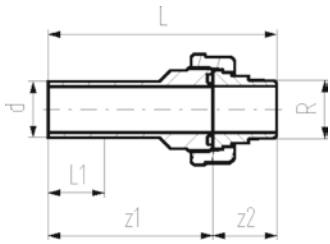

#### Model:

- Union bush: Spigot fitting PE100 SDR11, metric with free end
- Union End: Stainless steel 1.4404 / 316L with male thread R
- Gasket: O-ring EPDM No. 748 410 008-011
- Union Nut: PEGF25

d (mm)	Thread (inch)	Size (mm)	DN	SDR	PN	Code	Weight (kg)	L (mm)	L1 (mm)	z1 (mm)	z2 (mm)
32	R	1	25	11	16	<b>738 540 708</b>	0.276	147	36	107	40
40	R	1 ¼	32	11	16	<b>738 540 709</b>	0.495	163	40	117	46
50	R	1 ½	40	11	16	<b>738 540 710</b>	0.606	172	44	124	48
63	R	2	50	11	16	<b>738 540 711</b>	1.000	191	48	136	55

### COOL-FIT 2.0/4.0 Adaptor union PE/stainless steel With female thread Rp

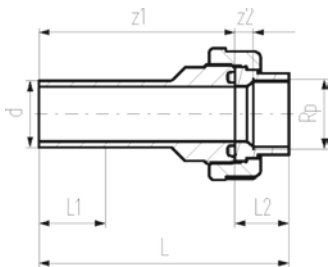

#### Model:

- Union bush: Spigot fitting PE100 SDR11, metric with free end
- Union End: Stainless steel 1.4404 / 316L with female thread Rp
- Gasket: O-ring EPDM No. 748 410 008-011
- Union Nut: PEGF25

d (mm)	Thread (inch)	Size (mm)	DN	SDR	PN	Code	Weight (kg)	L (mm)	L1 (mm)	L2 (mm)	z1 (mm)	z2 (mm)
32	Rp	1	25	11	16	<b>738 540 208</b>	0.234	136.0	36	29	107.0	10.0
40	Rp	1 ¼	32	11	16	<b>738 540 209</b>	0.387	150.0	40	33	117.5	11.0
50	Rp	1 ½	40	11	16	<b>738 540 210</b>	0.530	158.5	44	34	124.5	12.5
63	Rp	2	50	11	16	<b>738 540 211</b>	0.807	175.0	48	39	136.0	13.5

### COOL-FIT 2.0/4.0 Adaptor Fitting PE/iFIT

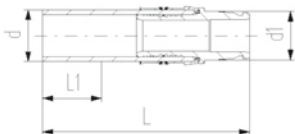

#### Model:

- Spigot fitting PE100 SDR11, metric with free end
- iFIT module stainless steel 1.4404 / 316L

d (mm)	DN (mm)	SDR	PN (bar)	Code	Weight (kg)	L (mm)	L1 (mm)	L2 (mm)
32	25	11	10	<b>738 940 108</b>	0.211	132	36	80



**COOL-FIT 2.0/4.0 Adaptor fitting PE/iFIT**

**Model:**

- Spigot fitting PE100 SDR11, metric with free end
- Push system module brass

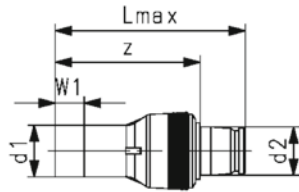

d1 (mm)	d2 (mm)	DN (mm)	SDR	PN (bar)	Code	SP	Weight (kg)	Lmax (mm)	W1 (mm)	z (mm)
32	25/32	25	11	16	<b>738 950 058</b>	1	0.219	115	36	87

**COOL-FIT 2.0/4.0 Adaptor fitting PE/Sanipex MT**



**Model:**

- Spigot fitting PE100 SDR11, metric with free end
- Sanipex MT adaptor brass CuZn40Pb2

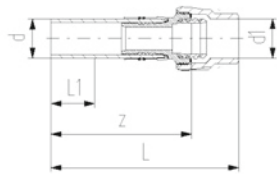

d (mm)	DN (mm)	SDR	PN (bar)	Code	Weight (kg)	d1 (mm)	L (mm)	L1 (mm)	L2 (mm)	z (mm)
32	25	11	10	<b>738 950 118</b>	0.412	32	174	36	101	135

**COOL-FIT 2.0/4.0 Transition cap PE/brass  
With female thread Rp**



**Model:**

- Spigot fitting PE100 SDR11, metric with free end
- Brass CuZn40Pb2 with female tread Rp
- Gasket: O-ring EPDM

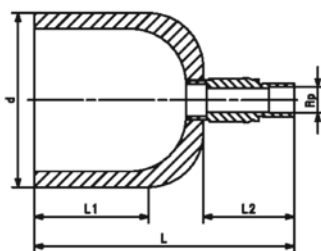

d (mm)	Thread Size (inch)	DN (mm)	SDR	PN (bar)	Code	Weight (kg)	L (mm)	L1 (mm)	L2 (mm)
32	Rp ½	25	11	16	<b>738 960 008</b>	0.200	107	36	69
40	Rp ½	32	11	16	<b>738 960 009</b>	0.210	113	40	73
50	Rp ½	40	11	16	<b>738 960 010</b>	0.250	117	44	73
63	Rp ½	50	11	16	<b>738 960 011</b>	0.300	121	48	73
75	Rp ½	65	11	16	<b>738 960 012</b>	0.400	128	55	73
90	Rp ½	80	11	16	<b>738 960 013</b>	0.476	135	62	73
110	Rp ½	100	11	16	<b>738 960 014</b>	0.695	145	72	73
140	Rp ½	125	11	16	<b>738 960 016</b>	0.954	209	84	73
160	Rp ½	150	11	16	<b>738 960 017</b>	1.300	193	90	73
225	Rp ½	200	11	16	<b>738 960 020</b>	2.532	221	110	73











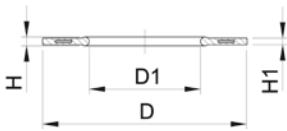

d (mm)	DN (mm)	PN (bar)	EPDM Code	FKM Code	Weight (kg)	D (mm)	D1 (mm)	di FA (mm)	H (mm)	H1 (mm)
280	250	16	<b>748 440 722</b>	<b>749 440 722</b>	0.323	328	274	264 - 274	8	6
315	300	16	<b>748 440 723</b>	<b>749 440 723</b>	0.549	378	306	296 - 306	8	6
355	350	16	<b>748 440 724</b>	<b>749 440 724</b>	0.870	438	355	340 - 355	10	7
400	400	16	<b>748 440 725</b>	<b>749 440 725</b>	1.088	489	400	385 - 400	10	7
450	500	10	<b>748 440 726</b>	<b>749 440 726</b>	0.718	594	403	393 - 403	10	7
500	500	10	<b>748 440 727</b>	<b>749 440 727</b>	0.718	594	447	437 - 447	10	7
560	600	10	<b>748 440 728</b>	<b>749 440 728</b>	0.923	695	494	484 - 494	10	7
630	600	10	<b>748 440 729</b>	<b>749 440 729</b>	0.923	695	555	545 - 555	10	7
710	700	6	<b>748 440 730</b>		0.890	810	712	562 - 712	6	3
800	800	6	<b>748 440 731</b>		1.340	917	813	663 - 813	6	3
900	900	6	<b>748 440 732</b>		1.170	1017	915	765 - 915	6	3
1000	1000	6	<b>748 440 733</b>		1.360	1124	1016	866 - 1016	6	3



### COOL-FIT 2.0 Sliding coupler kit

#### Model:

- Pre-insulated PE100 SDR11, metric
- Insulation made from GF HE foam
- Outer jacket impact resistant. Color: black
- Integrated sealing lip, for a moisture-proof and vapour tight sealing
- Including two couplers, pipe section and four insulation half shells

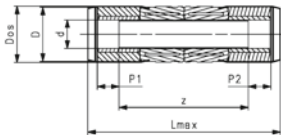

d (mm)	D (mm)	DN (mm)	SDR	PN (bar)	Code	Weight (kg)	Dos (mm)	Lmax (mm)	P1 (mm)	P2 (mm)	z (mm)
32	75	25	11	16	<b>738 914 508</b>	0.311	82	376	36	36	268
40	90	32	11	16	<b>738 914 509</b>	0.446	97	402	40	40	284
50	90	40	11	16	<b>738 914 510</b>	0.589	97	422	44	44	296
63	110	50	11	16	<b>738 914 511</b>	0.907	117	452	48	48	318
75	125	65	11	16	<b>738 914 512</b>	1.309	133	493	55	55	344
90	140	80	11	16	<b>738 914 513</b>	1.890	148	532	62	62	370
110	160	100	11	16	<b>738 914 514</b>	3.078	168	604	72	72	420
140	200	125	11	16	<b>738 914 516</b>	4.851	208	673	84	84	466

# COOL-FIT 2.0 Weld-in Port



## COOL-FIT 2.0 Weld-in port PE/brass With female thread Rp

### Model:

- Material: PE100, brass with low lead content, dezincification resistant
- With Weld-in port cone (PE100) and female thread Rp (brass) for the installation of sensors, instruments, venting and draining
- Gasket: O-ring EPDM
- Including insulation made from EPDM foam

### Note:

For pipes COOL-FIT 2.0, COOL-FIT 2.0F, COOL-FIT 4.0 and COOL-FIT 4.0F of the dimension d63-d225

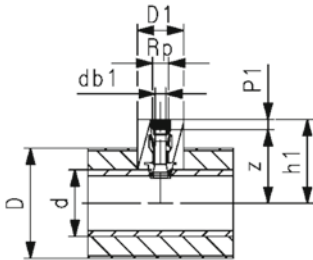

Size (inch)	Thread	PN (bar)	Code	Weight (kg)	d (mm)	db1 (mm)	D1 (mm)	h1 (mm)	P1 (mm)	z (mm)
½	Rp	16	<b>738 114 106</b>	0.140	d63 - d225	11.8	73	85+d/2	15	70 + d/2
¾	Rp	16	<b>738 114 107</b>	0.183	d63 - d225	17.4	73	85+d/2	16	69 + d/2
1	Rp	16	<b>738 114 108</b>	0.247	d63 - d225	23.1	73	86+d/2	19	67 + d/2



## COOL-FIT 2.0 Weld-in port PE/iFIT

### Model:

- Material: PE100, brass
- With Weld-in port cone (PE100) and iFIT module (brass) for the transition to COOL-FIT Push System or iFIT
- Gasket: O-ring EPDM
- Including insulation made from EPDM foam

### Note:

For pipes COOL-FIT 2.0, COOL-FIT 2.0F, COOL-FIT 4.0 and COOL-FIT 4.0F of the dimension d63-d225

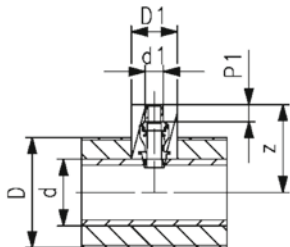

d1 (mm)	PN (bar)	Code	Weight (kg)	d (mm)	D1 (mm)	P1 (mm)	z (mm)
16/20	16	<b>738 114 406</b>	0.143	d63 - d225	73	20	84 + d/2



**COOL-FIT 2.0/4.0 Weld-in port PE/iFIT**

**Model:**

- Material: PE100, brass
- With Weld-in port cone (PE100) and iFIT module (brass) for the transition to COOL-FIT Push System or iFIT
- Gasket: O-ring EPDM

**Note:**

For pipes COOL-FIT 2.0, COOL-FIT 2.0F, COOL-FIT 4.0 and COOL-FIT 4.0F of the dimension d63-d225

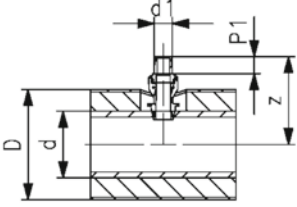

d1 (mm)	PN (bar)	Code	Weight (kg)	d	P1	z
25/32	16	<b>738 110 407</b>	0.228	d63 - d225	28	92 + d/2



**COOL-FIT 2.0 Weld-in port PE/Sanipex MT**

**Model:**

- Material: PE100, brass with low lead content, dezincification resistant
- With Weld-in port cone (PE100) and Sanipex MT adaptor (brass) for the transition to Sanipex MT
- Gasket: O-ring EPDM
- Including insulation made from EPDM foam

**Note:**

For pipes COOL-FIT 2.0, COOL-FIT 2.0F, COOL-FIT 4.0 and COOL-FIT 4.0F of the dimension d63-d225

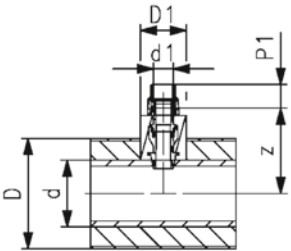

d1 (mm)	PN (bar)	Code	Weight (kg)	d	db1	D1	P1	z
32	16	<b>738 114 508</b>	0.240	d63 - d225	11.8	73	39	49 + d/2



**COOL-FIT 2.0 Weld-in port PE spigot**

**Model:**

- Material: PE100
- With Weld-in port cone (PE100) and metric spigot SDR11 for transitions to COOL-FIT 2.0 fittings type A or PE Fittings
- Including insulation made from EPDM foam

**Note:**

For pipes COOL-FIT 2.0, COOL-FIT 2.0F, COOL-FIT 4.0 and COOL-FIT 4.0F

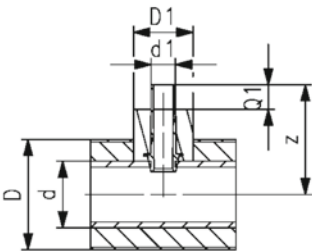

d1 (mm)	SDR	PN (bar)	Code	Weight (kg)	d	D1	Q1	z
32	11	16	<b>738 114 608</b>	0.070	d63 - d225	73	36	125 + d/2
40	11	16	<b>738 114 609</b>	0.104	d75 - d225	86	40	131 + d/2
50	11	16	<b>738 114 610</b>	0.152	d90 - d225	92	44	140 + d/2

# COOL-FIT 2.0 Flexible Hoses

## COOL-FIT 2.0 Flexible hose



### Model:

- EPDM flexible hose with stainless steel protection
- Brass adaptors
- Pre-Insulation made from NBR foam with outer jacket impact resistant and tearproof
- With loose union nut G on one end and male thread GA on the other

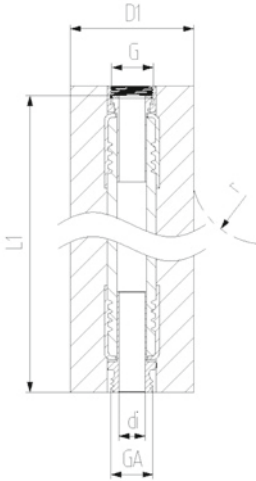

d (mm)	D1 (mm)	Thread	Size (inch)	DN (mm)	PN (bar)	Code	di (mm)	L1 (mm)	r (mm)
20	39	G/GA	1/2"	15	10	<b>738 924 206</b>	15	1000	119
25	44	G/GA	3/4"	20	10	<b>738 924 207</b>	19	1000	156
32	51	G/GA	1"	25	10	<b>738 924 208</b>	25	1000	192
40	59	G/GA	1 1/4"	32	8	<b>738 924 209</b>	32	1500	252
50	69	G/GA	1 1/2"	40	6	<b>738 924 210</b>	38	2000	312
63	82	G/GA	2"	50	6	<b>738 924 211</b>	52	2000	372

# COOL-FIT 2.0 Valves



## COOL-FIT 2.0 Ball valve hand-operated

### Model:

- Material: PVC-U with spigot PE100 SDR11, metric
- Ball seals type 542-PE/ blue lever ; type 546 PTFE/ red lever
- Integrated stainless steel mounting inserts for type 546
- Including insulation half shells

d (mm)	DN (mm)	PN	kv-value ( $\Delta p=1$ bar) (L/min)	Code	Weight (kg)
32	25	16	700	<b>138 541 308</b>	0.550
40	32	16	1000	<b>138 541 309</b>	0.892
50	40	16	1600	<b>138 541 310</b>	1.187
63	50	16	3100	<b>138 541 311</b>	2.153
75	65	16	5000	<b>138 546 312</b>	5.550
90	80	16	7000	<b>138 546 313</b>	8.150

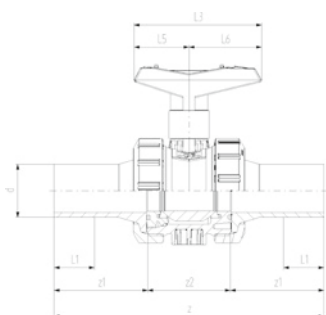

d (mm)	D (mm)	D1 (mm)	D2 (mm)	H (mm)	H1 (mm)	H2 (mm)	L (mm)	L1 (mm)	L3 (mm)	L4 (mm)	L5 (mm)	L6 (mm)	M	Type	z (mm)
32	135	97	82	97	34		152	36	93		34	59		542	223
40	157	117	97	114	42		170	40	110		41	69		542	249
50	169	117	97	120	49		184	44	180		41	69		542	271
63	204	132	117	141	62		227	48	128		49	79		542	321
75	235	147	132	194	85	15	276	55	270	70	64	206	M8	546	386
90	255	168	147	200	105	15	297	62	270	70	64	206	M8	546	421

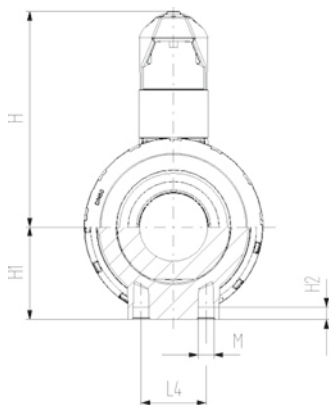

d (mm)	z1 (mm)	z2 (mm)
32	76	71
40	82	85
50	91	89
63	110	101
75	125	136
90	140	141

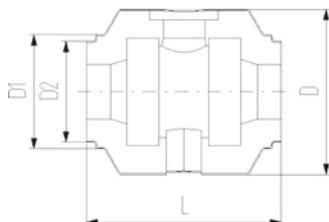



**COOL-FIT 2.0 Ball valve type 546 Pro**  
bare shaft

**Model:**

- Material: PVC-U with spigot PE100 SDR11, metric
- Ball seat PTFE
- Integrated stainless steel mounting inserts
- Interface according to DIN EN ISO 5211
- Including insulation half shells

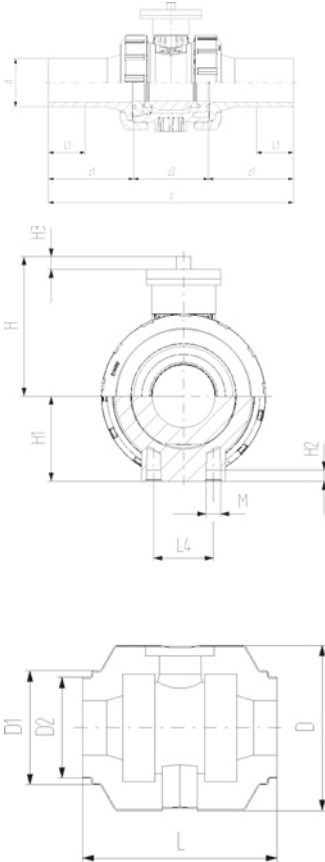

d (mm)	DN (mm)	PN	kv-value ( $\Delta p=1$ bar) (l/min)	SDR	EPDM Code	Weight (kg)
32	25	16	700	11	<b>138 546 408</b>	0.560
40	32	16	1000	11	<b>138 546 409</b>	0.900
50	40	16	1600	11	<b>138 546 410</b>	1.190
63	50	16	3100	11	<b>138 546 411</b>	2.110
75	65	16	5000	11	<b>138 546 412</b>	5.550
90	80	16	7000	11	<b>138 546 413</b>	8.150

d (mm)	D (mm)	D1 (mm)	D2 (mm)	H (mm)	H1 (mm)	H2 (mm)	H3 (mm)	Hole pattern	L (mm)	L1 (mm)	M	z (mm)	z1 (mm)	z2 (mm)
32	135	97	82	72	36	12	11	F05/F03	152	36	M6	223	76	71
40	157	117	97	84	44	15	11	F05/F03	170	40	M8	249	82	85
50	169	117	97	90	51	15	11	F05/F03	184	44	M8	271	91	89
63	204	132	117	105	64	15	10	F05/F03	227	48	M8	321	110	101
75	235	147	132	177	85	15	21	F07	276	55	M8	386	125	136
90	235	168	147	189	105	15	21	F07	297	62	M8	421	140	141



### COOL-FIT 2.0 Wafer-style butterfly valve kit type 567 Hand lever with ratchet settings

**Model:**

- Material: PVC-U with spigot PE100 SDR11, metric
- Including flange adaptors, backing flanges PP-Steel, bolts and insulation half shells

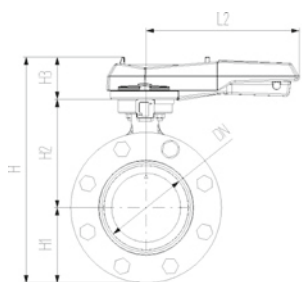

d (mm)	DN (mm)	PN	kv-value (Δp=1 bar) (l/min)	EPDM Code	Weight (kg)
110	100	10	6500	<b>138 567 314</b>	3.500
140	125	10	11500	<b>138 567 316</b>	4.500

d (mm)	D (mm)	D1 (mm)	D2 (mm)	L (mm)	L1 (mm)	L2 (mm)	L3 (mm)	H (mm)	H1 (mm)	H2 (mm)	H3 (mm)	z (mm)	z1 (mm)	z2 (mm)
110	260	188	168	552	72	255	106	325	104	167	55	696	320	56
140	287	233	208	662	84	255	106	352	117	181	55	830	383	64

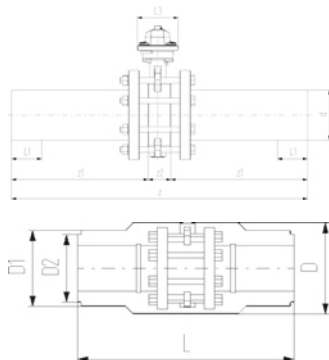

### COOL-FIT 2.0 Butterfly valve kit type 567 PVC-U Bare shaft

**Model:**

- Material: PVC-U with spigot PE100 SDR11, metric
- Interface F07 according to DIN/ISO 5211
- Including flange adaptors, backing flanges PP-Steel, bolts and insulation half shells

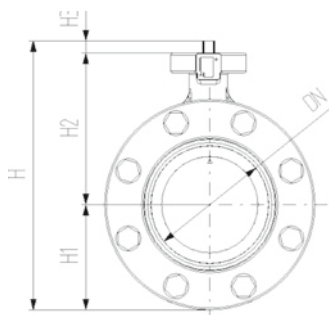

d (mm)	DN (mm)	PN	kv-value (Δp=1 bar) (l/min)	EPDM Code
110	100	10	6500	<b>138 567 414</b>
140	125	10	11500	<b>138 567 416</b>

d (mm)	D (mm)	D1 (mm)	D2 (mm)	L (mm)	L1 (mm)	L3 (mm)	H1 (mm)	H2 (mm)	H3 (mm)	z (mm)	z1 (mm)	z2 (mm)
110	260	188	168	552	72	106	104	167	55	696	320	56
140	287	233	208	662	84	106	117	181	55	830	383	64

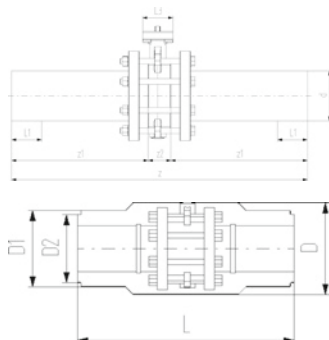





**Wafer-style, intermediate installation butterfly valve type 565 PVDF/PA-GF  
With hand lever  
Flange standard metric/ANSI/BS/JIS  
Suitable for ABS, PVC-U, PVC-C, ecoFIT, COOL-FIT and PROGEF Systems**

**Model:**

- Installation length: EN558 row 20, ISO 5752 row 20, API 609 table 2
- Flange standards: ISO 7005 PN10/16, EN 1092 PN10/16, DIN 2501 PN10/16, ANSI/ASME B 16.5 Class 150, BS 1560: 1989 Class 125/150; BS 4504 PN10/16, JIS B 2220 10K, JIS B 2239 10K
- For easy installation and removal
- Lockable ergonomic lever
- Suitable for water and water treatment applications (e.g. sea water, drinking water and industrial water)

**Option:**

- Individual configuration of the valve possible
- Pneumatic or electric actuators from GF
- Double sensor for electrical position feedback incl. LED feedback

**Note:**

For some material combination (e.g. DN300 valves with PE/PP pipes) special flange adapters are needed. Please check the "Perfect flange connection tool" on [www.gfps.com](http://www.gfps.com)

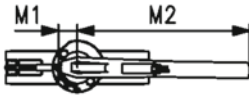
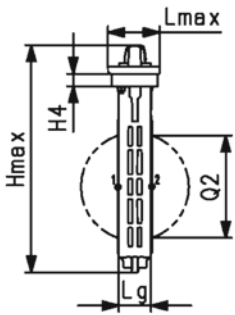
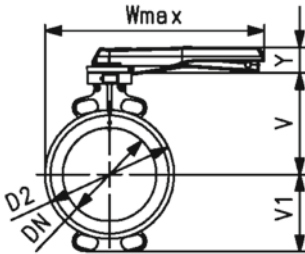

d	Size	DN	PN	kv-value	EPDM	SP	Weight	FKM	SP	Weight
(mm)	(inch)	(mm)	(bar)	( $\Delta p=1$ bar)	Code		(kg)	Code		(kg)
63	2	50	16	1445	199 565 000	1	1.3	199 565 020	1	1.4
75	2 ½	65	16	2530	199 565 001	1	1.5	199 565 021	1	1.6
90	3	80	16	4020	199 565 002	1	1.7	199 565 022	1	1.8
110	4	100	16	5850	199 565 003	1	2.5	199 565 023	1	2.7
140	5	125	16	11900	199 565 004	1	3.1	199 565 024	1	3.3
160	6	150	16	18050	199 565 005	1	4.0	199 565 025	1	4.3
225	8	200	10	43667	199 565 006	1	5.3	199 565 026	1	5.7

d	D2	Wmax	Hmax	Lmax	H4	V	V1	Lg	M1	M2	Y	Q2
(mm)	(mm)	(mm)	(mm)	(mm)	(mm)	(mm)	(mm)	(mm)	(mm)	(mm)	(mm)	(mm)
63	100.0	264.0	249.5	96.0	23.0	133.5	63.0	43.0	35.5	204.5	53.0	28.5
75	121.0	271.0	275.5	96.0	23.0	140.0	82.0	46.0	35.5	204.5	53.0	44.0
90	138.0	273.5	288.0	96.0	23.0	146.0	89.0	46.0	35.5	204.5	53.0	63.5
110	158.5	334.0	324.0	96.0	23.0	166.5	104.0	52.0	35.5	254.5	53.0	84.0
140	187.0	348.0	351.0	96.0	23.0	180.0	118.0	56.0	35.5	254.5	53.0	110.5
160	213.0	426.0	372.5	96.0	23.0	189.0	130.5	56.0	35.5	319.5	53.0	137.5
225	267.0	453.0	422.0	96.0	23.0	209.5	159.0	60.0	35.5	319.5	53.0	190.5



### Wafer-style, intermediate installation butterfly valve type 565 PVDF/PA-GF

#### Bare shaft

Flange standard metric/ANSI/BS/JIS Suitable for ABS, PVC-U, PVC-C, ecoFIT, COOL-FIT and PROGEF Systems

#### Model:

- Installation length: EN558 row 20, ISO 5752 row 20, API 609 table 2
- Flange standards: ISO 7005 PN10/16, EN 1092 PN10/16, DIN 2501 PN10/16, ANSI/ASME B 16.5 Class 150, BS 1560: 1989 Class 125/150; BS 4504 PN10/16, JIS B 2220 10K, JIS B 2239 10K
- For easy installation and removal
- Suitable for water and water treatment applications (e.g. sea water, drinking water and industrial water)

#### Option:

- Individual configuration of the valve possible
- Hand (lockable), pneumatic or electric actuators from GF
- Double sensor for electrical position feedback incl. LED feedback

#### Note:

For some material combination (e.g. DN300 valves with PE/PP pipes) special flange adapters are needed. Please check the "Perfect flange connection tool" on [www.gfps.com](http://www.gfps.com)

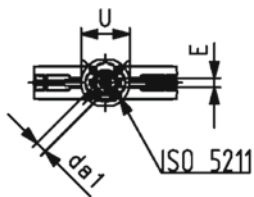
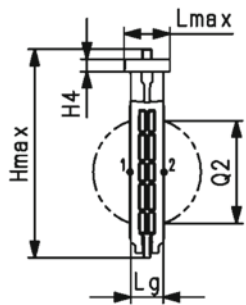
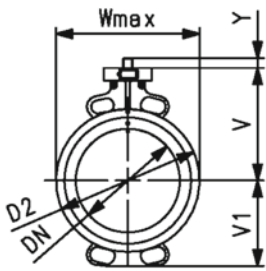

d (mm)	DN (mm)	Size (inch)	PN (bar)	kv-value ( $\Delta p=1$ bar) (L/min)	Acc.to ISO 5211	EPDM Code	SP	Weight (kg)
63	50	2	16	1445	F07	<b>199 565 100</b>	1	0.9
75	65	2 ½	16	2530	F07	<b>199 565 101</b>	1	1.1
90	80	3	16	4020	F07	<b>199 565 102</b>	1	1.3
110	100	4	16	5850	F07	<b>199 565 103</b>	1	2.0
140	125	5	16	11900	F07	<b>199 565 104</b>	1	2.6
160	150	6	16	18050	F07	<b>199 565 105</b>	1	3.7
225	200	8	10	43667	F07	<b>199 565 106</b>	1	4.7
280	250	10	10	62333	F10	<b>199 565 107</b>	1	8.8
315	300	12	6	94500	F10	<b>199 565 108</b>	1	12.6

d (mm)	FKM Code	SP	Weight (kg)
63	<b>199 565 120</b>	1	1.0
75	<b>199 565 121</b>	1	1.2
90	<b>199 565 122</b>	1	1.4
110	<b>199 565 123</b>	1	2.2
140	<b>199 565 124</b>	1	2.9
160	<b>199 565 125</b>	1	3.8
225	<b>199 565 126</b>	1	5.2
280	<b>199 565 127</b>	1	9.5
315	<b>199 565 128</b>	1	13.7

d (mm)	D2 (mm)	Wmax (mm)	Lmax (mm)	Hmax (mm)	H4 (mm)	V (mm)	V1 (mm)	Lg (mm)	da1 (mm)	E (mm)	U (mm)	Y (mm)	Q2 (mm)
63	100.0	118.5	85.5	222.5	23.0	133.5	63.0	43.0	14.1	11.0	90.0	27.0	28.5
75	121.0	132.5	85.5	248.5	23.0	140.0	82.0	46.0	14.1	11.0	90.0	27.0	44.0
90	138.0	138.0	85.5	261.0	23.0	146.0	89.0	46.0	14.1	11.0	90.0	27.0	63.5
110	158.5	158.5	85.5	286.0	23.0	166.5	104.0	52.0	18.1	14.0	90.0	16.0	84.0
140	187.0	187.0	85.5	313.5	23.0	180.0	118.0	56.0	18.1	14.0	90.0	16.0	110.5
160	213.0	213.0	85.5	337.5	23.0	189.0	130.5	56.0	22.2	17.0	90.0	19.0	137.5
225	267.0	267.0	85.5	387.0	23.0	209.5	159.0	60.0	22.2	17.0	90.0	18.5	190.5
280	325.5	325.5	125.0	498.5	23.0	262.5	195.5	68.0	28.2	22.0	125.0	40.5	239.0
315	380.0	380.0	125.0	555.0	23.0	284.5	230.5	78.0	28.2	22.0	125.0	40.5	285.5



**ecoFIT Ventilating and bleed valve Type 591**  
**With butt fusion spigots long**  
**PE100 SDR11 metric**

**Model:**

- Material: PVC-U/PE
- With protection cap up to DN50 made of PP-GF, DN65-100 made of POM
- Floater made of PP-H
- Designed for easy installation and removal
- Compact installation length

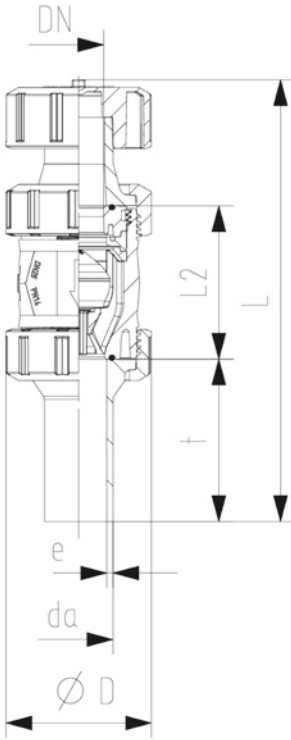

d	DN	PN	EPDM	FKM	D	L	L2	t	e	closest inch
(mm)	(mm)	(bar)	Code	Code	(mm)	(mm)	(mm)	(mm)	(mm)	(inch)
20	15	16	161 591 121	161 591 130	50	175	56	69	2.25	½
25	20	16	161 591 122	161 591 131	58	195	65	76	2.30	¾
32	25	16	161 591 123	161 591 132	68	207	71	76	2.90	1
40	32	16	161 591 124	161 591 133	84	230	85	82	3.70	1 ¼
50	40	16	161 591 125	161 591 134	97	254	89	91	4.60	1 ½
63	50	16	161 591 126	161 591 135	124	298	101	110	5.80	2
75	65	16	161 591 127	161 591 136	166	334	136	125	6.80	2 ½
90	80	16	161 591 128	161 591 137	200	360	141	140	8.20	3
110	100	16	161 591 129	161 591 138	238	411	164	160	10.00	4

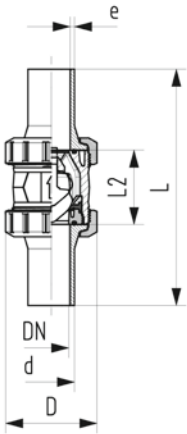

**ecoFIT Check valve type 561 PVC-U**  
**Without spring**  
**With butt fusion spigots long PE100 SDR11 metric**

**Model:**

- Material: PVC-U/PE
- Designed for easy installation and removal
- Vibration free even at high flow velocity
- Flow-optimized return cone, double guided
- For vertical installation
- Compact installation length, same as ball valve type 546
- Z-length, end connectors and union nuts **not** compatible with type 360

d	DN	Size	PN	kv-value	SDR	EPDM	Weight	FKM	Weight
(mm)	(mm)	(inch)	(bar)	( $\Delta p=1$ bar)		Code	(kg)	Code	(kg)
20	15	½	16	180	11	<b>161 561 142</b>	0.130	<b>800 050 344</b>	0.130
25	20	¾	16	380	11	<b>161 561 143</b>	0.260	<b>800 050 345</b>	0.250
32	25	1	16	460	11	<b>161 561 144</b>	0.300	<b>800 050 346</b>	0.320
40	32	1 ¼	16	850	11	<b>161 561 145</b>	0.520	<b>800 050 308</b>	0.530
50	40	1 ½	16	1080	11	<b>161 561 146</b>	0.780	<b>800 050 347</b>	0.810
63	50	2	16	1670	11	<b>161 561 147</b>	1.410	<b>800 050 348</b>	1.530
75	65	2 ½	10	2950	11	<b>161 561 148</b>	3.260	<b>800 050 837</b>	3.160
90	80	3	10	3600	11	<b>161 561 149</b>	5.170	<b>800 048 959</b>	5.520
110	100	4	10	4150	11	<b>161 561 150</b>	8.310	<b>800 050 839</b>	8.930

d	D	L	L2	e	closest
(mm)	(mm)	(mm)	(mm)	(mm)	inch
20	50	193	56	2.3	½
25	58	216	65	2.3	¾
32	68	223	71	3.0	1
40	84	249	85	3.7	1 ¼
50	97	271	89	4.6	1 ½
63	124	321	101	5.8	2
75	166	386	136		2 ½
90	200	421	141	8.2	3
110	238	484	164	10.0	4

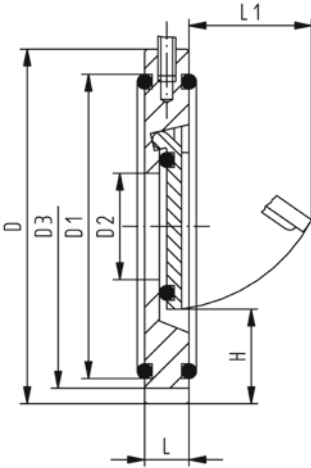

## Wafer check valve type 369 PVC-U Without spring

### Model:

- Supporting eyelets for simple fitting
- Suitable for vertical and horizontal mounting

### Installation instruction:

- Installation between ISO/DIN (all dimensions) and ANSI/BS flange adaptors (all except DN32 and DN125)
- Installation with ANSI/BS flange adaptor: for wafer check valves DN40 to DN80 you have to use ANSI/BS flange adaptors with the next bigger dimension (example DN40 wafer check valve between DN50 ANSI/BS flange adaptor)
- Centering by body diameter (ISO/DIN by D3, ANSI/BS by D)
- Sealing with special flange gasket (except DN32, o-ring)
- A stabilizing zone of at least 5 times nominal diameter (DN) should be provided before and after the wafer check valve (10 times DN is recommended)
- No direct installation on pump flange or following bend allowed
- The using of PVC-U pipe PN16 is only possible up to d63
- Wafer check valves without reset spring are not recommended for pulsating flows (production of noise)

d (mm)	DN (mm)	Size (inch)	PN (bar)	EPDM Code	SP Weight (kg)	FKM Code	SP Weight (kg)
40	32	1 ¼	10	161 369 002	1 0.110	161 369 022	1 0.108
50	40	1 ½	10	161 369 003	1 0.174	161 369 023	1 0.202
63	50	2	10	161 369 004	1 0.273	161 369 024	1 0.277
75	65	2 ½	10	161 369 005	1 0.352	161 369 025	1 0.386
90	80	3	10	161 369 006	1 0.560	161 369 026	1 0.591
110	100	4	10	161 369 007	1 0.651	161 369 027	1 0.667
140	125	5	10	161 369 009	1 0.791	161 369 029	1 0.856
160	150	6	6	161 369 010	1 1.153	161 369 030	1 1.207
225	200	8	6	161 369 011	1 2.215	161 369 031	1 2.306
280	250	10	6	161 369 012	1 3.850	161 369 032	1 3.915
315	300	12	6	161 369 013	1 7.059	161 369 033	1 5.300

d (mm)	D (mm)	D1 (mm)	D2 (mm)	D3 (mm)	L (mm)	L1 (mm)	H (mm)	Opening pressure vertical (mbar)	Opening pres- sure horizontal (mbar)	Minimum water col- umn for seal- ing (m)
40	85	59	18		15	22	25	10	1	2
50	105	77	22	95	16	27	27	10	1	2
63	124	92	32	109	18	40	29	10	1	2
75	137	111	40	129	20	55	31	10	1	2
90	175	131	54	144	20	67	32	10	1	2
110	175	153	70	164	23	77	31	10	1	2
140	195	185	92		23	94	35	10	1	2
160	222	198	105	220	26	100	41	10	1	2
225	279	259	154	275	34	152	38	18	1	2
280	340	311	192	330	40	180	41	18	1	2
315	410	347	227	380	45	215	41	18	1	2



**Wafer check valve type 369 PVC-U  
With V4A spring (stainless steel 316)**

**Model:**

- Supporting eyelets for simple fitting
- Suitable for vertical and horizontal mounting

**Installation instruction:**

- Installation between ISO/DIN (all dimensions) and ANSI/BS flange adaptors (all except DN32 and DN125)
- Installation with ANSI/BS flange adaptor: for wafer check valves DN40 to DN80 you have to use ANSI/BS flange adaptors with the next bigger dimension (example DN40 wafer check valve between DN50 ANSI/BS flange adaptor)
- Centering by body diameter (ISO/DIN by D3, ANSI/BS by D)
- Sealing with special flange gasket (except DN32, o-ring)
- A stabilizing zone of at least 5 times nominal diameter (DN) should be provided before and after the wafer check valve (10 times DN is recommended)
- No direct installation on pump flange or following bend allowed
- The using of PVC-U pipe PN16 is only possible up to d63

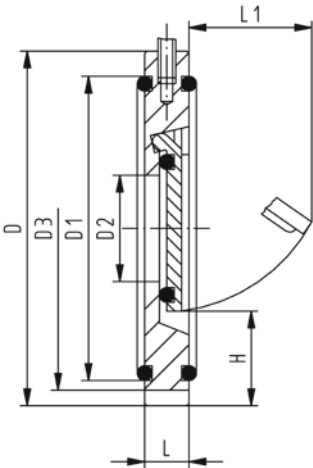

d (mm)	DN (mm)	Size (inch)	PN (bar)	EPDM Code	SP Weight (kg)	FKM Code	SP Weight (kg)
40	32	1 ¼	10	161 369 042	1 0.130	161 369 062	1 0.107
50	40	1 ½	10	161 369 043	1 0.160	161 369 063	1 0.206
63	50	2	10	161 369 044	1 0.273	161 369 064	1 0.250
75	65	2 ½	10	161 369 045	1 0.357	161 369 065	1 0.320
90	80	3	10	161 369 046	1 0.561	161 369 066	1 0.390
110	100	4	10	161 369 047	1 0.651	161 369 067	1 0.684
140	125	5	10	161 369 049	1 0.791	161 369 069	1 0.750
160	150	6	6	161 369 050	1 1.171	161 369 070	1 1.100
225	200	8	6	161 369 051	1 2.252	161 369 071	1 2.100
280	250	10	6	161 369 052	1 3.790	161 369 072	1 3.500
315	300	12	6	161 369 053	1 6.274	161 369 073	1 5.300

d (mm)	D (mm)	D1 (mm)	D2 (mm)	D3 (mm)	L (mm)	L1 (mm)	H (mm)	Opening pressure vertical (mbar)	Opening pres- sure horizontal (mbar)	Minimum water col- umn for seal- ing (m)
40	85	59	18		15	22	25	30	20	2
50	105	77	22	95	16	27	27	30	20	2
63	124	92	32	109	18	40	29	30	20	2
75	137	111	40	129	20	55	31	30	20	2
90	175	131	54	144	20	67	32	30	20	2
110	175	153	70	164	23	77	31	30	20	2
140	195	185	92		23	94	35	30	20	2
160	222	198	105	220	26	100	41	30	20	2
225	279	259	154	275	34	152	38	38	20	2
280	340	311	192	330	40	180	41	38	20	2
315	410	347	227	380	45	215	41	38	20	2

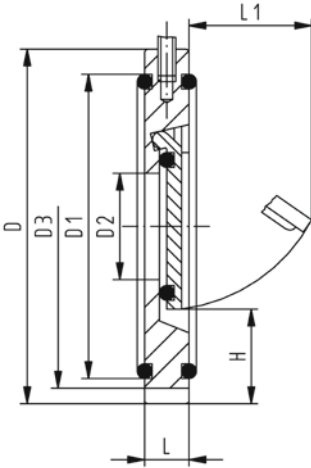

**Wafer check valve type 369 PVC-U  
With Hastelloy C spring**

**Model:**

- Supporting eyelets for simple fitting
- Suitable for vertical and horizontal mounting

**Installation instruction:**

- Installation between ISO/DIN (all dimensions) and ANSI/BS flange adaptors (all except DN32 and DN125)
- Installation with ANSI/BS flange adaptor: for wafer check valves DN40 to DN80 you have to use ANSI/BS flange adaptors with the next bigger dimension (example DN40 wafer check valve between DN50 ANSI/BS flange adaptor)
- Centering by body diameter (ISO/DIN by D3, ANSI/BS by D)
- Sealing with special flange gasket (except DN32, o-ring)
- A stabilizing zone of at least 5 times nominal diameter (DN) should be provided before and after the wafer check valve (10 times DN is recommended)
- No direct installation on pump flange or following bend allowed
- The using of PVC-U pipe PN16 is only possible up to d63

d (mm)	DN (mm)	Size (inch)	PN (bar)	EPDM Code	SP Weight (kg)	FKM Code	SP Weight (kg)
40	32	1 ¼	10	161 369 082	1	0.130	161 369 102
50	40	1 ½	10	161 369 083	1	0.174	161 369 103
63	50	2	10	161 369 084	1	0.250	161 369 104
75	65	2 ½	10	161 369 085	1	0.320	161 369 105
90	80	3	10	161 369 086	1	0.390	161 369 106
110	100	4	10	161 369 087	1	0.654	161 369 107
140	125	5	10	161 369 089	1	0.750	161 369 109
160	150	6	6	161 369 090	1	1.164	161 369 110
225	200	8	6	161 369 091	1	2.100	161 369 111
280	250	10	6	161 369 092	1	3.500	161 369 112
315	300	12	6	161 369 093	1	5.300	161 369 113

d (mm)	D (mm)	D1 (mm)	D2 (mm)	D3 (mm)	L (mm)	L1 (mm)	H (mm)	Opening pressure vertical (mbar)	Opening pres- sure horizontal (mbar)	Minimum water col- umn for seal- ing (m)
40	85	59	18		15	22	25	30	20	2
50	105	77	22	95	16	27	27	30	20	2
63	124	92	32	109	18	40	29	30	20	2
75	137	111	40	129	20	55	31	30	20	2
90	175	131	54	144	20	67	32	30	20	2
110	175	153	70	164	23	77	31	30	20	2
140	195	185	92		23	94	35	30	20	2
160	222	198	105	220	26	100	41	30	20	2
225	279	259	154	275	34	152	38	38	20	2
280	340	311	192	330	40	180	41	38	20	2
315	410	347	227	380	45	215	41	38	20	2



**ecoFIT Diaphragm valve type 514**  
**With butt and electro fusion ends PE100 SDR11 metric**

**Model:**

- Material: PVC-U/PE
- Double flow rate compared to predecessor
- One housing nut replaces four screws
- Handwheel with built-in locking mechanism
- For easy installation and removal
- Short overall length

**Option:**

- Individual configuration of the valve
- Self adjusting multifunctional module with integrated limit switches
- PN16 available as a configuration

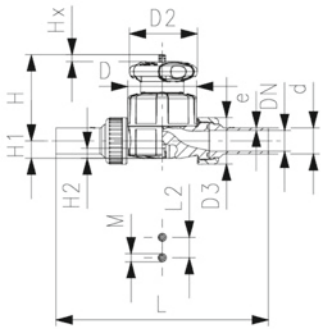

d (mm)	DN (mm)	Size (inch)	PN (bar)	kv-value ( $\Delta p=1$ bar) (l/min)	EPDM Code	Weight (kg)
20	15	½	10	125	<b>161 514 312</b>	0.357
25	20	¾	10	271	<b>161 514 313</b>	0.431
32	25	1	10	481	<b>161 514 314</b>	0.683
40	32	1 ¼	10	759	<b>161 514 315</b>	1.443
50	40	1 ½	10	1263	<b>161 514 316</b>	1.663
63	50	2	10	1728	<b>161 514 317</b>	2.568

d (mm)	D (mm)	D2 (mm)	D3 (mm)	L (mm)	L2 (mm)	H (mm)	H1 (mm)	H2 (mm)	M	Lift = Hx (mm)	e (mm)	closest inch (inch)
20	65	65	43	196	25	73	14	12	M6	7	1.9	½
25	80	65	51	221	25	81	18	12	M6	10	2.3	¾
32	88	87	58	234	25	107	22	12	M6	13	2.9	1
40	101	87	72	260	45	115	26	15	M8	15	3.7	1 ¼
50	117	135	83	284	45	148	32	15	M8	19	4.6	1 ½
63	144	135	100	321	45	166	39	15	M8	25	5.8	2



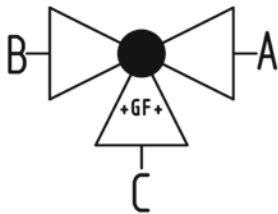
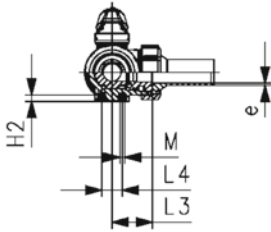
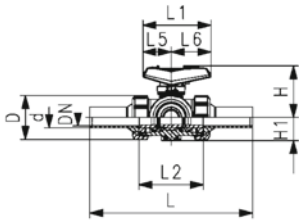
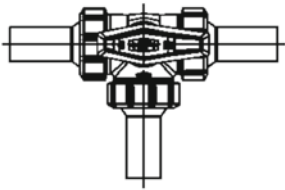

**ecoFIT 3-Way ball valve type 543 Pro PVC-U**  
**Horizontal/L-port**  
**With butt fusion spigots long PE100 SDR11 metric**

**Model:**

- Material: PVC-U/PE
- Lockable lever as standard (DN10-DN50)
- For easy installation and removal (valve end and union nut are compatible with type 546)
- Ball seat PTFE
- Angle of operation 360° without turn limiter
- Turn limiter 90° enclosed, in different positions usable as a clip-on ring
- Integrated stainless steel mounting inserts
- Delivery status A-C opened, see flow scheme
- Z-dimension, valve end and union nut are compatible with type 543 (1stGeneration)

**Option:**

- Interface-module with position feedback sensor, incl. LED feedback (DN10-50)
- Manual spring return lever ("Dead man") (DN10-25)
- Pneumatic or electric actuators from GF
- Individual configuration of the valve possible

d	DN	Size	PN	kv-value	EPDM	Weight	FKM	Weight
(mm)	(mm)	(inch)	(bar)	( $\Delta p=1$ bar)	Code	(kg)	Code	(kg)
				(L/min)				
20	15	½	10	75	161 543 462	0.254	161 543 472	0.254
25	20	¾	10	150	161 543 463	0.370	161 543 473	0.370
32	25	1	10	280	161 543 464	0.563	161 543 474	0.563
40	32	1 ¼	10	480	161 543 465	0.953	161 543 475	0.953
50	40	1 ½	10	620	161 543 466	1.444	161 543 476	1.444
63	50	2	10	1230	161 543 467	3.141	161 543 477	3.141

d	D	L	L1	L2	L3	L4	L5	L6	H	H1	H2	M	e	closest
(mm)	(mm)	(mm)	(mm)	(mm)	(mm)	(mm)	(mm)	(mm)	(mm)	(mm)	(mm)	(mm)	(mm)	inch
														(inch)
20	50	210	82	73	36	25	35	47	61	28	8	6	1.9	½
25	58	237	106	86	43	25	44	62	74	32	8	6	2.3	¾
32	68	251	106	99	50	25	44	62	80	36	8	6	2.9	1
40	84	283	131	120	60	45	57	74	95	45	9	8	3.7	1 ¼
50	97	319	131	137	69	45	57	74	102	51	9	8	4.6	1 ½
63	124	399	152	179	89	45	66	86	117	65	9	8	5.8	2

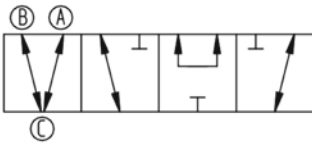
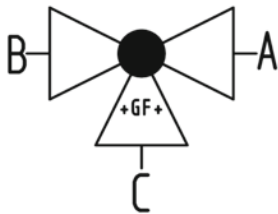
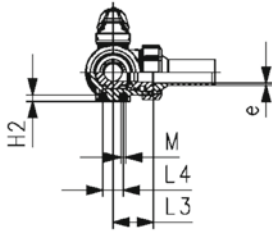
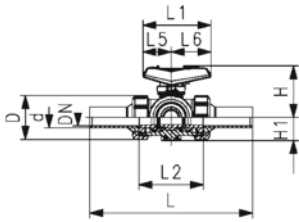
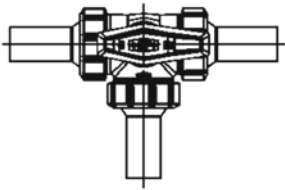

**ecoFIT 3-Way ball valve type 543 Pro PVC-U**  
**Horizontal/T-port**  
**With butt fusion spigots long PE100 SDR11 metric**

**Model:**

- Material: PVC-U/PE
- Lockable lever as standard (DN10-DN50)
- For easy installation and removal (valve end and union nut are compatible with type 546)
- Ball seat PTFE
- Angle of operation 360° without turn limiter
- Turn limiter 90° enclosed, in different positions usable as a clip-on ring
- Integrated stainless steel mounting inserts
- Delivery status A-B-C opened, see flow scheme
- Z-dimension, valve end and union nut are compatible with type 543 (1stGeneration)

**Option:**

- Interface-module with position feedback sensor, incl. LED feedback (DN10-50)
- Manual spring return lever ("Dead man") (DN10-25)
- Pneumatic or electric actuators from GF
- Individual configuration of the valve possible

d	DN	Size	PN	kv-value	EPDM	Weight	FKM	Weight
(mm)	(mm)	(inch)	(bar)	( $\Delta p=1$ bar)	Code	(kg)	Code	(kg)
20	15	½	10	200	<b>161 543 482</b>	0.253	<b>161 543 492</b>	0.253
25	20	¾	10	470	<b>161 543 483</b>	0.368	<b>161 543 493</b>	0.368
32	25	1	10	793	<b>161 543 484</b>	0.556	<b>161 543 494</b>	0.556
40	32	1 ¼	10	1290	<b>161 543 485</b>	0.942	<b>161 543 495</b>	0.942
50	40	1 ½	10	1910	<b>161 543 486</b>	1.423	<b>161 543 496</b>	1.423
63	50	2	10	3100	<b>161 543 487</b>	2.770	<b>161 543 497</b>	3.096

d	D	L	L1	L2	L3	L4	L5	L6	H	H1	H2	M	e	closest
(mm)	(mm)	(mm)	(mm)	(mm)	(mm)	(mm)	(mm)	(mm)	(mm)	(mm)	(mm)	(mm)	(mm)	inch
20	50	210	82	73	36	25	35	47	61	28	8	6	1.9	½
25	58	237	106	86	43	25	44	62	74	32	8	6	2.3	¾
32	68	251	106	99	50	25	44	62	80	36	8	6	2.9	1
40	84	283	131	120	60	45	57	74	95	45	9	8	3.7	1 ¼
50	97	319	131	137	69	45	57	74	102	51	9	8	4.6	1 ½
63	124	399	152	179	89	45	66	86	117	65	9	8	5.8	2

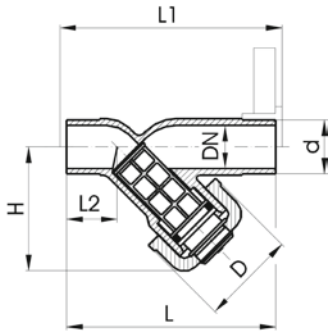

**Line strainer type 305 PVC-U**  
**With solvent cement spigots metric**

**Model:**

- Protects valves, pumps, etc. from becoming soiled
- Easy dismantling for cleaning the screens
- **Screen perforation need be ordered separately**
- Overall length according to EN 558

d (mm)	DN (mm)	Size (inch)	PN (bar)	EPDM Code	SP Weight (kg)	FKM Code	SP Weight (kg)
20	15	½	10	<b>161 305 300</b>	1	<b>161 305 349</b>	0.134
25	20	¾	10	<b>161 305 350</b>	1	<b>161 305 399</b>	0.215
32	25	1	10	<b>161 305 400</b>	1	<b>161 305 449</b>	0.257
40	32	1 ¼	10	<b>161 305 450</b>	1	<b>161 305 499</b>	0.386
50	40	1 ½	10	<b>161 305 500</b>	1	<b>161 305 549</b>	0.632
63	50	2	10	<b>161 305 550</b>	1	<b>161 305 599</b>	1.045
75	65	2 ½	10	<b>161 305 600</b>	1	<b>161 305 649</b>	1.871
90	80	3	10	<b>161 305 650</b>	1	<b>161 305 699</b>	2.585

d (mm)	D (mm)	H (mm)	L (mm)	L1 (mm)	L2 (mm)	closest inch (inch)
20	43	65	124	130	28	½
25	47	76	144	150	37	¾
32	56	90	154	160	37	1
40	64	104	174	180	44	1 ¼
50	82	124	194	200	48	1 ½
63	95	148	224	230	60	2
75	106	188	284	290	74	2 ½
90	120	205	300	310	85	3

# COOL-FIT 2.0 Accessories

## Tools



### COOL-FIT 2.0/4.0 Foam removal and peeling tool

**Model:**

- Tool for foam removal and peeling of COOL-FIT 2.0 and 4.0 pipes

d (mm)	Code	Weight (kg)	SDR
32-90	<b>799 738 001</b>	10.500	SDR11
110-225	<b>799 738 003</b>	16.500	d110+d140 SDR11; d160+d225 SDR17
250-450	<b>799 738 004</b>	71.000	SDR17



### COOL-FIT 2.0/4.0 Upgrade kit foam removal and peeling tool d140-d225

**Model:**

- Upgrade for COOL-FIT 2.0/4.0 foam removal and peeling tool d110-d225 (799738003)
- For easier foam removal and peeling of COOL-FIT 2.0 and 4.0 pipes in the dimensions d140-d225

**Note:**

Spindle and clamping shoes are to be used of COOL-FIT 2.0/4.0 foam removal and peeling tool 799738003

d (mm)	Code	Weight (kg)
140-225	<b>799 738 013</b>	50.000

## MSA 2.1 Automatic Electrofusion Unit with protocols retrieval



The MSA 2.1 automatic electro fusion unit combines light weight and high efficiency, thanks to its inverter technology and furthermore provides fusion documentation in PDF. The unit is extremely fast and simple, with three basic operations required to operator: connect, scan, start the fusion. It is robust, safe and ergonomic.

All is meant to simplify the job: the barcode scanner, for long distance reading, the cooling system to joint in series, the icon system, to keep the interaction between user and machine intuitive. The entire welding process is controlled and regulated with energy output compensation depending on ambient temperature and the indication of cooling time.

The internal Bluetooth Low Energy device offers the possibility to enter data, monitor the fusion from remote and collect the data recorded via wireless with consumer smartphones, to send them to the headquarter even in real time.

The unit has 1000 protocols permanently stored in the internal memory. The user can copy the fusion reports in an USB stick to print them out in PDF format.

Scope of delivery includes: transport box, angle adapters (4.0 mm and 4.7 mm), operating instructions, START/STOP badge and USB memory stick with PC applications.

### Technical Data:

- Operating temperature: -20°C to +50°C
- Mains voltage and frequency: 230V (190V - 265V), 50-60Hz
- Fusion voltage: 8-42 V (48 V)
- Fusion data input mode: bar code, manual
- Fusion current: 90 A (max)
- Suggested power generators: 3.5 kVA
- USB Port: Type A
- Protection factor: Class 1 / IP 65
- Mains cable: 4 m (8 m only for code 790156010) / Fusion cable: 4 m
- Weight: ca. 11.9 kg
- Display: Graphical LCD, adjustable contrast
- Independent from languages
- Bluetooth radio interface

	Type	Code	Weight (kg)
Barcode scanner, transport case, mini Welding Book		<b>790 156 003</b>	11.900
Barcode scanner, transport case, mini Welding Book, Swiss plug		<b>790 156 006</b>	11.900
Barcode scanner, transport case, mini Welding Book, 8m fusion cable		<b>790 156 010</b>	12.900
Barcode scanner, transport case, mini Welding Book, German version		<b>790 156 009</b>	19.500



## COOL-FIT 2.0/4.0 Installation tool weld-in port

### Model:

- Tool for the installation of weld-in ports to COOL-FIT pipes
- Complete: toolcase equipped with all necessary tool components to install weld-in ports 1/2"-1" and d16-d50
- Basic: toolcase equipped with all necessary tool components to install weld-in ports 1/2"-1" and d16-d32 and the possibility to upgrade with d40+d50
- Upgrade kit: kit to upgrade basic tool to complete tool
- Version 230V with AC power plug CEE 7/4 (Schuko)
- Version 110V with AC power plug NEMA 5-15 grounded (Type B)

### Note:

For pipes COOL-FIT 2.0, COOL-FIT 2.0F, COOL-FIT 4.0 and COOL-FIT 4.0F of the dimension d63-d225

Type A) Complete: toolcase equipped with all necessary tool components to install weld-in ports 1/2"-1" and d16-d50

Type B) Basic: toolcase equipped with all necessary tool components to install weld-in ports 1/2"-1" and d16-d32 and the possibility to upgrade with d40+d50

Type C) Upgrade kit: kit to upgrade basic tool to complete tool

Type	Tension	Code	Weight (kg)
A	230 V	<b>799 738 300</b>	20.700
B	230 V	<b>799 738 301</b>	14.100
A	110 V	<b>799 738 302</b>	20.700
B	110 V	<b>799 738 303</b>	14.100
C		<b>799 738 310</b>	7.000



### Clamping tool Double, multi size with universal link

- Recommended for the installation of fittings ELGEF Plus and ecoFIT d40 - 200 and d160 - 630mm
- Recommended for the installation of fittings COOL-FIT d32/D75 - d140/D200 and d160/D250 - d450/D630
- The clamping allows installation without tension and avoids movement during fusion and cooling time
- The centrally located adjustable universal link allows installation of electrofusion couplers, elbows and reducers
- Works above, below and alongside the joint
- Adaptor for use with Tee-pieces available (see accessories)

d (mm)	d1 (mm)	Code	Weight (kg)
40	200	<b>799 301 490</b>	4.200
160	630	<b>799 301 496</b>	14.100

d (mm)	Description	Length (mm)	Width (mm)	Height (mm)
40	Scope of delivery: 2 x V-block, 2 x Straight bar, 1 x Universal link, Transport bag (600x380x250)	900	290	230
160	Scope of delivery: 2 x V-block, 2 x Straight bar, 1 x Universal link, Transport bag (780x780x580)	1300	670	550

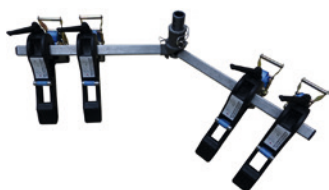

### Clamping tool Quadruple, multi size with universal link

- Recommended for the installation of fittings ELGEF Plus and ecoFIT d40 - 200 and d160 - 630mm
- Recommended for the installation of fittings COOL-FIT d32/D75 - d140/D200 and d160/D250 - d450/D630
- The clamping allows installation without tension and avoids movement during fusion and cooling time
- The centrally located adjustable universal link allows installation of electrofusion couplers, elbows and reducers
- Universal use; works above, below and alongside the joint
- Adaptor for use with Tee-pieces available (see accessories)

d (mm)	d1 (mm)	Code	Weight (kg)
40	200	<b>799 301 489</b>	8.300
160	630	<b>799 301 495</b>	23.300

d (mm)	Description	Length (mm)	Width (mm)	Height (mm)
40	Scope of delivery: 4 x V-block, 2 x Straight bar, 1 x Universal link	900	290	230
160	Scope of delivery: 4 x V-block, 2 x Straight bar, 1 x Universal link	1300	670	550



### Tee adaptor

- Suitable for clamping tool (799301495)

d (mm)	d1 (mm)	Code	Weight (kg)	Description	Length (mm)	Width (mm)	Height (mm)
40	200	<b>799 301 491</b>	0.610	Tee adaptor	600	50	40
160	630	<b>799 301 497</b>	3.500	Tee adaptor	1070	75	60



### V-block

- Suitable for clamping tool (799301495)

d (mm)	d1 (mm)	Code	Weight (kg)	Description	Length (mm)	Width (mm)	Height (mm)
40	200	<b>799 301 492</b>	1.000	V-block complete	290	230	65
160	630	<b>799 301 498</b>	3.200	V-block complete	660	430	90



### Bar extension

- Suitable for clamping tool (799301495)

d (mm)	d1 (mm)	Code	Weight (kg)	Description	Length (mm)	Width (mm)	Height (mm)
160	630	<b>799 301 499</b>	1.000	Bar extension	1000	40	40

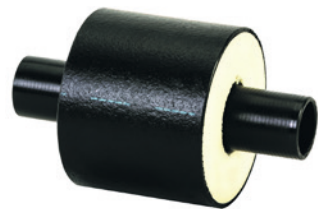

### COOL-FIT 2.0 Barrel nipple with insulation, d32-d140

#### Model:

- Pre-insulated PE100 SDR11 metric
- Insulation made from GF HE foam
- Impact resistant. Color: black
- For short connections between COOL-FIT 2.0 Fittings Typ A

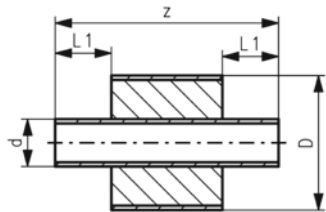

d (mm)	D (mm)	SDR	PN (bar)	Code	Weight (kg)	L1 (mm)	z (mm)
32	75	11	16	<b>738 914 408</b>	0.072	36	121
40	90	11	16	<b>738 914 409</b>	0.104	40	125
50	90	11	16	<b>738 914 410</b>	0.136	44	133
63	110	11	16	<b>738 914 411</b>	0.216	48	141
75	125	11	16	<b>738 914 412</b>	0.313	55	155
90	140	11	16	<b>738 914 413</b>	0.459	62	169
110	160	11	16	<b>738 914 414</b>	0.712	72	189
140	200	11	16	<b>738 914 416</b>	1.226	90	213



### COOL-FIT 2.0/4.0 Barrel nipple

#### Model:

- PE100, SDR11/17, metric
- For the shortest possible connection between fittings
- For media temperatures between 0°C up to 60°C
- COOL-FIT 4.0 Adhesive ring needed for joining

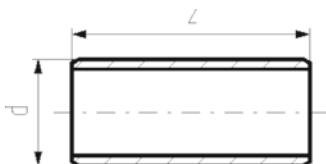

d (mm)	DN (mm)	SDR	PN	Code	Weight (kg)	z (mm)
32	25	11	16	<b>738 910 408</b>	0.020	72
40	32	11	16	<b>738 910 409</b>	0.034	80
50	40	11	16	<b>738 910 410</b>	0.059	88
63	50	11	16	<b>738 910 411</b>	0.101	96
75	65	11	16	<b>738 910 412</b>	0.162	110
90	80	11	16	<b>738 910 413</b>	0.264	124
110	100	11	16	<b>738 910 414</b>	0.454	144
140	125	11	16	<b>738 910 416</b>	0.855	168
160	150	17	10	<b>738 910 417</b>	0.798	180
225	200	17	10	<b>738 910 420</b>	1.885	220



### COOL-FIT 2.0/4.0 adhesive ring

**Model:**

- Double sided, for sealing connections of fittings with barrel nipple

D (mm)	d (mm)	d COOL-FIT 4.0 (mm)	d COOL-FIT 2.0 (mm)	Code	Weight (kg)
75	32		32	738 010 012	0.002
90	32 - 50	32	40 - 50	738 010 013	0.002
110	40 - 63	40 - 50	63	738 010 014	0.003
125	63 - 75	63	75	738 010 015	0.003
140	75 - 90	75	90	738 010 016	0.003
160	90 - 110	90	110	738 010 017	0.005
180	110	110		738 010 018	0.005
200	140		140	738 010 019	0.006
225	140	140		738 010 020	0.009
250	160	160		738 010 021	0.009
315	225	225		738 010 023	0.027



### COOL-FIT 2.0/4.0 Fixed point

**Model:**

- The product consists of two components namely electrofusion tapes and pipe brackets.
- Electrofusion welded tape as permanent connection to transmit the forces that occur in the pipe to the fixed point.
- The delivered pipe brackets are needed to deliver welding pressure during installation and give stability during operation.
- For welding, use an MSA2.x, MSA4.x, MSA 250, 300, 350, 400 or commercially available 220 V fusion machines.
- If you use an MSA fusion machine from GF Piping Systems, use the 799 350 339 adapter or the 790 156 032 y-cable set.
- Please take note of the maximum allowed forces for this version in the table below.
- **Fixed point brackets and cross braces have to be calculated and obtained by the installer. They are not included in the fixed point set from GF.**

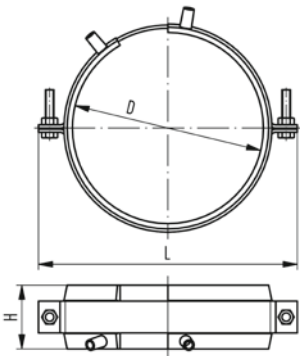

D (mm)	d (mm)	d COOL-FIT 4.0 (mm)	d COOL-FIT 2.0 (mm)	Code	Weight (kg)
75	32		32	738 912 012	0.750
90	32 - 50	32	40 - 50	738 912 013	0.895
110	40 - 63	40 - 50	63	738 912 014	0.904
125	63 - 75	63	75	738 912 015	1.103
140	75 - 90	75	90	738 912 016	1.188
160	90 - 110	90	110	738 912 017	1.177
180	110	110		738 912 018	1.530
200	140		140	738 912 019	1.600
225	140	140		738 912 020	1.813
250	160	160		738 912 021	1.957
315	225	225		738 912 023	2.388
355	250	250		738 912 024	2.388

D (mm)	d (mm)	L (mm)	H (mm)	max Force COOL-FIT 4.0 (kN)	max Force COOL-FIT 2.0 (kN)
75	32	150	60		2.0
90	32 - 50	170	60	2.0	3.0 / 5.0
110	40 - 63	180	60	3.0 / 5.0	8.0
125	63 - 75	215	60	8.0	10.0
140	75 - 90	220	60	10.0	10.0
160	90 - 110	255	60	10.0	10.0
180	110	255	60	10.0	
200	140	310	60		10.0



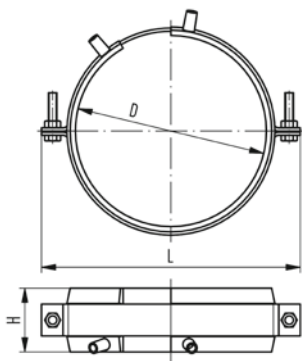

D (mm)	d (mm)	L (mm)	H (mm)	max Force COOL-FIT 4.0 (kN)	max Force COOL-FIT 2.0 (kN)
225	140	310	60	10.0	
250	160	335	60	10.0	
315	225	400	60	10.0	
355	250	420	60	10.0	



### COOL-FIT 2.0 Fixpoint kit for high forces

#### Model:

- The product consists of fixpoint, pipe section and insulation kit
- Fixed point for installation between two electrofusion fittings, transmits the forces emanating from the pipe to the fixed point
- Pipe section PE100 SDR11, metric
- Fixpoint with welding plate made from S235JR (1.0038). With corrosion protection coating
- Insulation made from EPDM soft foam. For outdoor application use additional protection
- Please take note of the maximum allowed forces for this version in the table below.
- A force calculation of the fixpoint clamp and the attachment point is required
- For the bonding, adhesive 738010060 is recommended
- Availability: From January 2023

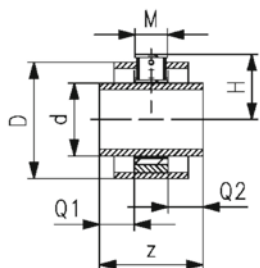

d (mm)	D (mm)	DN (mm)	SDR	PN (bar)	Code	Weight (kg)
140	200	125	11	16	<b>738 914 816</b>	7.950

z (mm)	Q1 (mm)	Q2 (mm)	Dos (mm)	H (mm)	M (mm)	E (mm)	Wrench size (mm)	max. Force (kN)
268	84	84	244	137	100	100	24	35

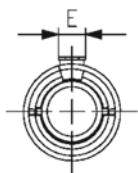

### COOL-FIT Y cables kit

- The COOL-FIT Y cables are used to speed up the installation of the fixed points electrofusion tapes. The Y cables allow the welding in parallel of 2 E-Tapes, halving the total duration of the fusion process.
- Compatible with all MSA Units

Type	Code	Weight (kg)
4 leads cable with 2mm plugs in output	<b>790 156 032</b>	0.385

## Hand scraper



- The Hand Scraper can be used to prepare the fusion zone on PE80 pipes.

Description	Code	Weight (kg)
Hand scraper with long handle	<b>799 198 094</b>	0.143



## COOL-FIT 2.0F fixed point set

### Model:

- Four PVC-U half shells as permanent connection to transmit the forces that occur in the pipe to the fixed point.
- For cementing use Tangit RAPID, Tangit RAPID static mixer and Tangit RAPID dispenser
- Please take note of the maximum allowed forces for this version in the table below.
- Fixed point brackets and cross braces have to be calculated and obtained by the installer. They are not included in the fixed point set from GF.**

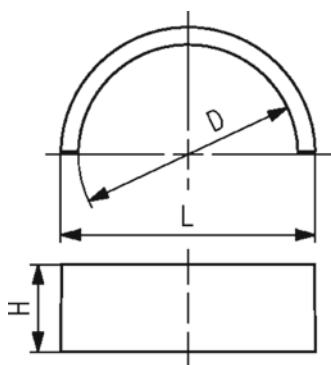

d (mm)	D (mm)	Code	Weight (kg)	L (mm)	H (mm)	max. Force (kN)	closest inch (inch)
32	75	<b>738 912 312</b>	0.750	87	30	2.0	1
40 - 50	90	<b>738 912 313</b>	0.895	105	35	3.0 / 5.0	1 ¼ / 1 ½
63	110	<b>738 912 314</b>	0.904	128	35	8.0	2
75	125	<b>738 912 315</b>	1.103	142	35	10.0	2 1/2
90	140	<b>738 912 316</b>	1.188	162	35	10.0	3
110	160	<b>738 912 317</b>	1.177	183	35	10.0	4
140	200	<b>738 912 319</b>	1.600	221	35	10.0	5



## Tangit Rapid cartridges kit

- 2-Component-Adhesive
- For PVC-U and PVC-C
- Tangit Rapid Kit consists of 6 cartridges, 12 mixers and 2 plastic brushes
- Tool needed: Tangit Rapid dispenser and mixers
- Check chemical resistance list ([www.gfps.com](http://www.gfps.com))

Language	description	Code	Weight (kg)
DE, FR	50 ml	<b>799 302 005</b>	0.566
FR, NL	50 ml	<b>799 302 041</b>	0.566
DK, SE	50 ml	<b>799 302 042</b>	0.566
GB, IT	50 ml	<b>799 302 043</b>	0.566
FI, NO	50 ml	<b>799 302 044</b>	0.566
DE, ES, FR, GB, IT, NL, PT	400 ml	<b>799 302 007</b>	3.700
DK, FI, NO, SE	400 ml	<b>799 302 047</b>	3.700



## Tangit Rapid mixer set

- For Tangit Rapid cartridges
- Bag with 30 pieces for 50ml and 15 pieces for 400ml

description	Code	SP	Weight (kg)
50ml	<b>799 302 032</b>	1	0.160
400ml	<b>799 302 033</b>	1	0.190



### Tangit Rapid dispenser

- For Tangit Rapid cartridges

d-d (mm)	description	Code	SP	Weight (kg)
16 - 140	50ml	<b>799 302 011</b>	1	0.185
110 - 400	400ml	<b>799 302 013</b>	1	1.100



### COOL-FIT 2.0/4.0 Adhesive cement

#### Model:

- For the jointing of NBR foam insulations of flexible hoses and transition fittings

Code	SP	Weight (kg)
<b>738 010 060</b>	1	0.240

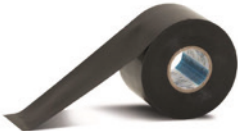

### COOL-FIT 2.0/4.0 Adhesive tape

#### Model:

- For the jointing of NBR foam insulations of flexible hoses and transition fittings
- 30m on a roll

Code	SP	Weight (kg)
<b>738 010 065</b>	1	0.400



### Tangit KS Cleaner

- Special cleaner for plastic fusion connections in the material of PE, PP, PB, PVDF, ECTFE and PVC-U
- Suitable for Tangit Rapid. Must not be used for solvent cementing
- DVGW approved
- DW 5290 BR 0464

Size	Code	Weight (kg)
1 liter	<b>799 298 023</b>	0.872



### Marker

Type	Code	Weight (kg)
silver	<b>799 350 364</b>	0.010

### Deburring tool

- Replacable blade



Code	SP	Weight (kg)
<b>790 205 082</b>	1	0.058

### Measuring tape (circumference and diameter)

- Circumference: 2 m / 79 inch
- Diameter: 630 mm / 25 inch



Code	SP	Weight (kg)
<b>790 205 087</b>	1	0.045

### KLIP-IT pipe clip type 061 PP metric



#### Model:

- Material: clip and safety clip PP black, UV resistant
- d16 - d63: height designed for ball valve type 546 and 543
- **Minimum order quantity: standard packagings SP**

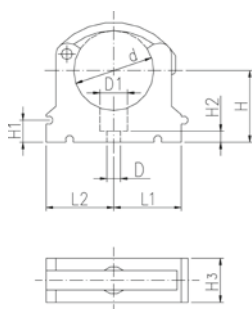

d (mm)	Code	SP	Weight (kg)
*	10	<b>167 061 003</b>	10 0.003
*	12	<b>167 061 004</b>	10 0.003
*	16	<b>167 061 035</b>	10 0.007
*	20	<b>167 061 036</b>	10 0.007
*	25	<b>167 061 037</b>	10 0.009
*	32	<b>167 061 038</b>	10 0.012
	40	<b>167 061 039</b>	10 0.027
	50	<b>167 061 040</b>	10 0.031
	63	<b>167 061 041</b>	10 0.052
	75	<b>167 061 012</b>	10 0.057
	90	<b>167 061 013</b>	10 0.092
	110	<b>167 061 014</b>	10 0.117
	125	<b>167 061 015</b>	10 0.180
	140	<b>167 061 016</b>	10 0.224
	160	<b>167 061 017</b>	10 0.242

d (mm)	D (mm)	D1 (mm)	H (mm)	H1 (mm)	H2 (mm)	H3 (mm)	L1 (mm)	L2 (mm)	SC	closest inch (inch)
*	10	5	8	20	10	6	12	14	M4	¼
*	12	5	8	21	10	6	12	14	M5	¼
*	16	6	11	27	10	6	16	17	M5	⅜
*	20	6	11	27	10	6	16	17	M5	½
*	25	6	11	30	10	6	16	19	M5	¾
*	32	6	11	36	10	6	16	24	M5	1
	40	7	14	44	10	7	22	34	M6	1 ¼
	50	7	14	51	10	7	22	37	M6	1 ½
	63	9	17	64	10	10	25	45	M8	2

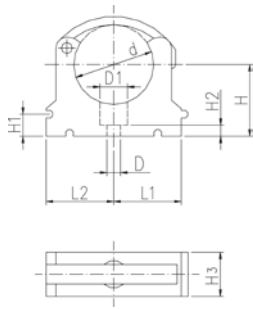

d (mm)	D (mm)	D1 (mm)	H (mm)	H1 (mm)	H2 (mm)	H3 (mm)	L1 (mm)	L2 (mm)	SC	closest inch (inch)
75	9	17	58	10	10	25	52	52	M8	2 ½
90	9	17	65	10	10	28	65	65	M8	3
110	9	17	75	10	10	28	79	79	M8	4
125	9	17	90	10	10	32	88	88	M8	
140	9	17	110	10	10	32	98	98	M8	5
160	9	17	108	10	10	32	109	109	M8	6



### KLIP-IT spacer type 061 PP

#### Model:

- For pipe clips type 061/061H, PP black, UV resistant
- **Minimum order quantity: standard packaging SP**

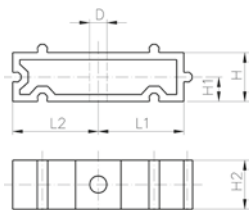

d (mm)	Inch	Code	SP	Weight (kg)	D (mm)	L1 (mm)	L2 (mm)	H (mm)	H1 (mm)	H2 (mm)	SC
10 - 12	¼ - ¼	<b>167 061 153</b>	10	0.003	5	11	14	20	10	12	M4
16	⅜	<b>167 061 155</b>	10	0.005	6	14	17	20	10	16	M5
20	½	<b>167 061 156</b>	10	0.005	6	17	19	20	10	16	M5
25	¾	<b>167 061 157</b>	10	0.007	6	19	22	20	10	16	M5
32	1	<b>167 061 158</b>	10	0.006	6	24	27	20	10	16	M5
40	1 ¼	<b>167 061 159</b>	10	0.015	7	34	34	20	10	22	M6
50	1 ½	<b>167 061 160</b>	10	0.017	7	37	37	20	10	22	M6
63	2	<b>167 061 161</b>	10	0.020	9	45	45	20	10	25	M8
75	2 ½	<b>167 061 162</b>	10	0.027	9	52	52	20	10	25	M8
90	3	<b>167 061 163</b>	10	0.039	9	65	65	20	10	28	M8
110	4	<b>167 061 164</b>	10	0.048	9	79	79	20	10	28	M8
125	4 ½	<b>167 061 165</b>	10	0.059	9	88	88	20	10	32	M8
140	5	<b>167 061 166</b>	10	0.065	9	98	98	20	10	32	M8
160	6	<b>167 061 167</b>	10	0.071	9	109	109	20	10	32	M8



### Pipe clip type 060 PP metric

#### Model:

- Material: clip and safety clip PP black, UV resistant
- **Minimum order quantity: standard packaging SP or gross packaging GP**
- Accidental opening of the safety clip is not possible
- Clip and safety clip are not assembled in the packaging.
- Pipes with flanges can be installed directly

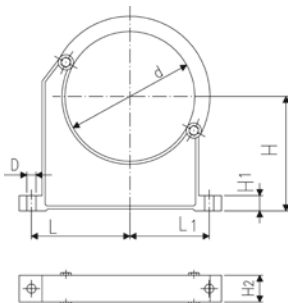

d (mm)	Code	SP	Weight (kg)	D (mm)	L (mm)	L1 (mm)	H (mm)	H1 (mm)	H2 (mm)	SC	closest inch (inch)
90	<b>167 060 038</b>	10	0.144	9	89	71	105	15	33	M 8	3
110	<b>167 060 039</b>	10	0.158	9	94	80	115	15	33	M 8	4
125	<b>167 060 040</b>	10	0.249	11	116	91	130	20	35	M10	
140	<b>167 060 041</b>	10	0.260	11	121	99	130	20	35	M10	5
160	<b>167 060 042</b>	10	0.296	11	131	107	148	20	35	M10	6
180	<b>167 060 043</b>	10	0.327	11	143	115	163	20	35	M10	7
200	<b>167 060 019</b>	5	0.539	13	151	120	175	25	39	M12	8
225	<b>167 060 020</b>	5	0.612	13	164	132	175	25	39	M12	8
250	<b>167 060 021</b>	5	0.657	13	183	143	200	25	39	M12	9
280	<b>167 060 022</b>	5	0.722	13	197	156	200	25	39	M12	10
315	<b>167 060 023</b>	5	0.805	13	219	171	225	25	39	M12	12
355	<b>167 060 024</b>	5	1.251	17	275	209	258	30	50	M16	14
400	<b>167 060 025</b>	4	1.031	17	300	228	288	30	50	M16	16

# COOL-FIT 2.0 Spare Parts



## COOL-FIT 2.0/4.0 Insulation for ball valve type 546 / 542

**Model:**

- Set consisting of half shells and clamps

**Note:**

Suitable for COOL-FIT ball valve only

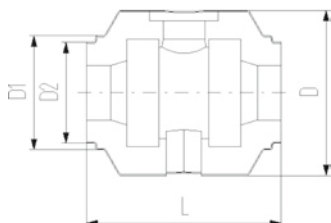

d (mm)	D (mm)	DN (mm)	Code	Weight (kg)	D1 (mm)	D2 (mm)	L (mm)
32	135	25	<b>738 990 308</b>	0.160	97	82	152
40	157	32	<b>738 990 309</b>	0.228	117	97	170
50	169	40	<b>738 990 310</b>	0.282	117	97	184
63	204	50	<b>738 990 311</b>	0.498	132	117	227
75	235	65	<b>738 990 312</b>	0.935	147	132	276
90	255	80	<b>738 990 313</b>	1.033	168	147	297



## COOL-FIT 2.0/4.0 Insulation for Butterfly Valve Type 567

**Model:**

- Set consisting of half shells and clamps

**Note:**

Suitable for COOL-FIT butterfly valve only

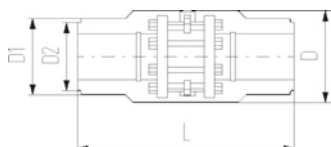

d (mm)	D (mm)	DN (mm)	Code	Weight (kg)	D1 (mm)	D2 (mm)	L (mm)
110	310	100	<b>738 990 324</b>	2.054	188	168	556
140	287	125	<b>738 990 326</b>	2.947	233	208	662
160	358	150	<b>738 990 327</b>	3.675	259		720
225	409	200	<b>738 990 330</b>	4.811	325		776

## COOL-FIT 2.0/4.0 Insulation for flange adaptor

**Model:**

- Set consisting of half shells and clamps

**Note:**

Suitable for COOL-FIT flange adaptor only

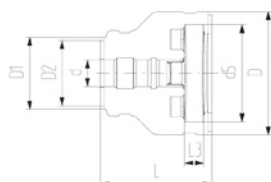

d (mm)	D (mm)	DN (mm)	Code	Weight (kg)	D1 (mm)	D2 (mm)	L (mm)	L3 (mm)	d5 (mm)
32	135	25	<b>738 990 458</b>	0.230	90	75	162	26	121
40	170	32	<b>738 990 459</b>	0.340	110	90	165	28	146
50	180	40	<b>738 990 460</b>	0.400	110	90	178	30	156
63	200	50	<b>738 990 461</b>	0.560	125	110	230	32	171
75	220	65	<b>738 990 462</b>	0.650	140	125	232	34	191
90	240	80	<b>738 990 463</b>	0.830	160	140	245	35	206
110	270	100	<b>738 990 464</b>	1.100	180	160	254	36	235
140	300	125	<b>738 990 466</b>	1.140	225	200	299	38	256
160	358	150	<b>738 990 467</b>	1.560	259		332	34	295
225	423	200	<b>738 990 470</b>	2.800	325		383	37	354



### COOL-FIT 2.0 Insulation for welding indicator

**Model:**

- Type A suitable for COOL-FIT 2.0 d32-d110 and d140 coupler
- Type B suitable for COOL-FIT 2.0 d140 except coupler

d (mm)	Code	Weight (kg)	Type	pieces/kit
32-140	<b>738 010 051</b>	0.055	A	20
140	<b>738 010 056</b>	0.010	B	10



### Peeling blade d32-d90

- Suitable for COOL-FIT 2.0/4.0 foam removal and peeling tool (799 738 001)

d (mm)	Code	Weight (kg)
32	<b>799 738 101</b>	0.015
40	<b>799 738 102</b>	0.020
50	<b>799 738 103</b>	0.019
63	<b>799 738 104</b>	0.020
75	<b>799 738 105</b>	0.020
90	<b>799 738 106</b>	0.030



### Peeling blade d110-d225

- Suitable for COOL-FIT 2.0/4.0 foam removal and peeling tool (799 738 003)

d (mm)	Code	Weight (kg)
110	<b>799 738 107</b>	0.100
140	<b>799 738 108</b>	0.100
160	<b>799 738 109</b>	0.100
225	<b>799 738 110</b>	0.100



### Replacement blade foam separator

- Suitable for COOL-FIT 2.0/4.0 foam removal and peeling tool (799 738 004) and upgrade kit d140-d225 (799 738 013)

Code	Weight (kg)	Suitable for
<b>799 738 115</b>	0.100	799 738 004
<b>799 738 117</b>	0.080	799 738 013



### O-Ring for clamping shoe

- Suitable for COOL-FIT 2.0/4.0 foam removal and peeling tool (799 738 001 and 799 738 003)

d (mm)	Code	Weight (kg)
32	<b>799 738 050</b>	0.003
110	<b>799 738 051</b>	0.010

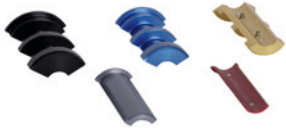

### Clamping shoe d32-d90

- Suitable for COOL-FIT 2.0/4.0 foam removal and peeling tool (799 738 001)

d (mm)	Code	Weight (kg)	Colour
32	<b>799 738 020</b>	0.240	silver
40	<b>799 738 021</b>	0.090	red
50	<b>799 738 022</b>	0.210	anthracite
63	<b>799 738 023</b>	0.120	gold
75	<b>799 738 024</b>	0.270	blue
90	<b>799 738 025</b>	0.480	black



### Clamping shoe d110-d225

- Suitable for COOL-FIT 2.0/4.0 foam removal and peeling tool (799 738 003)
- Type A: Spindle start
- Type B: With pipe stop

d (mm)	Code	Weight (kg)	Colour	Type
110	<b>799 738 026</b>	0.680	silver	
140	<b>799 738 027</b>	0.480	red	A
140	<b>799 738 037</b>	0.480	red	B
160	<b>799 738 028</b>	0.580	anthracite	A
160	<b>799 738 038</b>	0.580	anthracite	B
225	<b>799 738 029</b>	0.600	gold	A
225	<b>799 738 039</b>	0.600	gold	B



### Circular blade

- Suitable for COOL-FIT 2.0/4.0 foam removal and peeling tool (799 738 001 and 799 738 003)

Code	Weight (kg)
<b>799 738 040</b>	0.008



### Circular blade-Set

- Suitable for COOL-FIT 2.0/4.0 foam removal and peeling tool (799738001 and 799738003)
- Consists of: Circular blade, holder and screw

d (mm)	Code	Weight (kg)
32 - 90	<b>799 738 048</b>	0.025
110 - 225	<b>799 738 049</b>	0.025



### Saw

- Suitable for COOL-FIT 2.0/4.0 foam removal and peeling tool (799 738 003)

d (mm)	Code	Weight (kg)
140 - 225	<b>799 738 060</b>	1.000





### Saw blade

- Suitable for COOL-FIT 2.0/4.0 foam removal and peeling tool (799 738 003)

d (mm)	Code	Weight (kg)
140 - 225	<b>799 738 061</b>	0.029



### Spare blades for deburring tool

- 10 pieces

Code	SP	Weight (kg)
<b>790 205 083</b>	1	0.031

# COOL-FIT 2.0 Push System Pipes and Fittings

## COOL-FIT 2.0 Push System Pipe bar



### Model:

- Pre-insulated multilayer (PE-RT/AL/PE-RT) pipe, metric
- Closed cell insulation based EPDM with polyester wire mesh for mechanical protection
- Colour: black

d	D	DN	PN	Code	Weight	di	L	closest inch
(mm)	(mm)	(mm)	(bar)		(kg)	(mm)	(mm)	(inch)
16	44	12	16	<b>738 174 005</b>	0.299	12	5000	¾
20	48	15	16	<b>738 174 006</b>	0.354	16	5000	½
25	54	20	16	<b>738 174 007</b>	0.521	20	5000	¾
32	61	25	16	<b>738 174 008</b>	0.621	26	5000	1

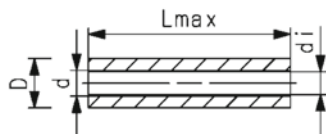

## COOL-FIT 2.0 Push System Pipe coiled



### Model:

- Pre-insulated multilayer (PE-RT/AL/PE-RT) pipe, metric
- Closed cell insulation based EPDM with polyester wire mesh for mechanical protection
- Colour: black

d	D	DN	PN	Code	Weight	di	L	closest inch
(mm)	(mm)	(mm)	(bar)		(kg)	(mm)	(mm)	(inch)
16	44	12	16	<b>738 174 055</b>	0.299	12	25000	¾
20	48	15	16	<b>738 174 056</b>	0.354	16	25000	½
25	54	20	16	<b>738 174 057</b>	0.521	20	25000	¾

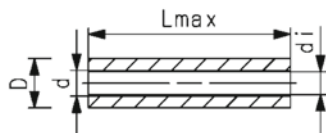



### COOL-FIT 2.0 Push System Coupler

**Model:**

- Push fitting made of high-performance plastic PPSU
- Insulation shell of EPP with TPE jacket
- Colour: black
- Package contents: 1x module, 2x adaptors, 2x compression rings, 1x insulation shell

d (mm)	D (mm)	DN (mm)	PN (bar)	Code	Weight (kg)	Dos (mm)	Lmax (mm)	z (mm)
16	44	12	16	<b>738 914 005</b>	0.266	69	190	53
20	48	15	16	<b>738 914 006</b>	0.254	69	190	53
25	54	20	16	<b>738 914 007</b>	0.456	86	212	72
32	61	25	16	<b>738 914 008</b>	0.446	86	212	72

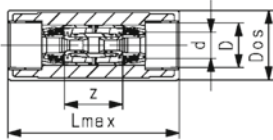

### COOL-FIT 2.0 Push System Elbow 90°

**Model:**

- Push fitting made of high-performance plastic PPSU
- Insulation shell of EPP with TPE jacket
- Colour: black
- Package contents: 1x module, 2x adaptors, 2x compression rings, 1x insulation shell

d (mm)	D (mm)	DN (mm)	PN (bar)	Code	Weight (kg)	Dos (mm)	Lmax (mm)	L1 (mm)	z (mm)
16	44	12	16	<b>738 104 005</b>	0.294	69	145	110	41
20	48	15	16	<b>738 104 006</b>	0.282	69	145	110	41
25	54	20	16	<b>738 104 007</b>	0.550	86	175	132	62
32	61	25	16	<b>738 104 008</b>	0.540	86	175	132	62

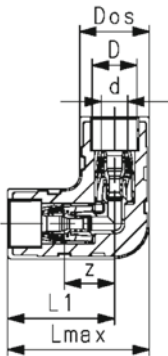

### COOL-FIT 2.0 Push System T90° equal



#### Model:

- Push fitting made of high-performance plastic PPSU
- Insulation shell of EPP with TPE jacket
- Colour: black
- Package contents: 1x module, 2x adaptors, 2x compression rings, 1x insulation shell

#### Note:

Additional COOL-FIT 2.0 Push System Adaptor kit needed for d16 and d20 738904055 or 73890456 for d25 and d32 738904057 or 73890458

d (mm)	d2 (mm)	D (mm)	DN (mm)	PN (bar)	Code	Weight (kg)	Dos (mm)	Lmax (mm)	L2 (mm)	z (mm)	z2 (mm)
16	16/20	44	12	16	<b>738 204 005</b>	0.344	69	207	110	72	37
20	16/20	48	15	16	<b>738 204 006</b>	0.332	69	207	110	72	37
25	25/32	54	20	16	<b>738 204 007</b>	0.648	86	246	132	106	54
32	25/32	61	25	16	<b>738 204 008</b>	0.638	86	246	132	106	54

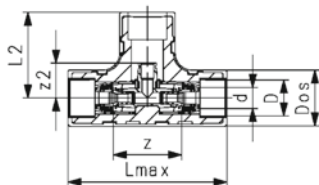

### COOL-FIT 2.0 Push System T90° reduced



#### Model:

- Push fitting made of high-performance plastic PPSU
- Insulation shell of EPP with TPE jacket
- Colour: black
- Package contents: 1x module, 2x adaptors, 2x compression rings, 1x insulation shell

#### Note:

Additional COOL-FIT 2.0 Push System, Adaptor kit 738904055 and 73890456 needed

d1 (mm)	d2 (mm)	D (mm)	DN (mm)	PN (bar)	Code	Weight (kg)	Dos1 (mm)	Dos2 (mm)	Lmax (mm)	L2 (mm)	z (mm)	z2 (mm)
25	16/20	54	20	16	<b>738 204 017</b>	0.597	86	69	246	121	106	48
32	16/20	61	25	16	<b>738 204 018</b>	0.587	86	69	246	121	106	48

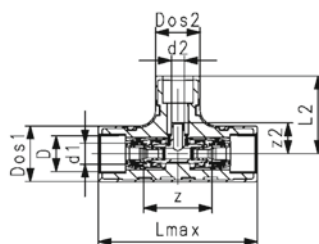



## COOL-FIT 2.0 Push System Reduction

### Model:

- Push fitting made of high-performance plastic PPSU
- Insulation shell of EPP with TPE jacket
- Colour: black
- Package contents: 1x module, 2x adaptors, 2x compression rings, 1x insulation shell

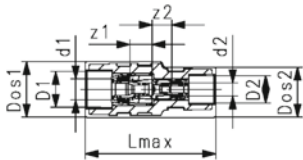

d1 (mm)	d2 (mm)	D1 (mm)	D2 (mm)	DN (mm)	PN (bar)	Code	Weight (kg)	Dos1 (mm)	Dos2 (mm)	Lmax (mm)	z1 (mm)	z2 (mm)
25	16	54	44	20	16	<b>738 904 015</b>	0.395	86	69	203	34	31
25	20	54	48	20	16	<b>738 904 016</b>	0.389	86	69	203	34	31
32	16	61	44	25	16	<b>738 904 017</b>	0.390	86	69	203	34	31
32	20	61	48	25	16	<b>738 904 018</b>	0.384	86	69	203	34	31

# COOL-FIT 2.0 Push System Valves



## COOL-FIT 2.0 Push System Ball valve

### Model:

- Ball valve with spindle extension
- Insulation shell of EPP with TPE jacket
- Colour: black
- Package contents: 1x ball valve, 2x adaptors, 2x compression rings, 1x insulation shell

d (mm)	D (mm)	DN (mm)	PN (bar)	Code	Weight (kg)	Dos (mm)	H (mm)	Lmax (mm)	M1 (mm)	M2 (mm)	z (mm)
16	44	12	16	<b>138 984 005</b>	0.739	69	108	232	14	84	97
20	48	15	16	<b>138 984 006</b>	0.732	69	108	232	14	84	97
25	54	20	16	<b>138 984 007</b>	1.155	86	111	246	14	84	116
32	61	25	16	<b>138 984 008</b>	1.145	86	111	246	14	84	116

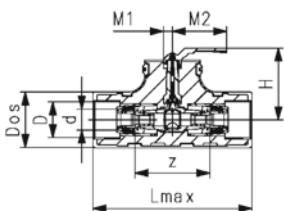

## COOL-FIT 2.0 Push System Flow control valve Both sides connection with Eurocone

### Model:

- Flow control valve made of brass, impact resistant plastic and EPDM seals
- Both sides connection to COOL-FIT 2.0 Push System
- Measuring accuracy:  $\pm 10\%$  of the displayed value
- Insulation made of NBR and shells of TPE
- Package contents: 1x valve, 2x adaptors, 2x compression rings, 1x insulation shell

d (mm)	D (mm)	DN (mm)	PN (bar)	Code	Weight (kg)	Dos (mm)	Lmax (mm)	z (mm)
16	44	12	10	<b>138 984 025</b>	0.625	69	252	82
20	48	15	10	<b>138 984 026</b>	0.669	69	252	86

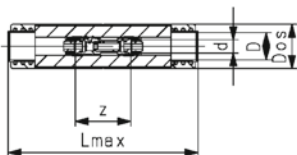

## COOL-FIT 2.0 Push System Flow control valve Both sides connection with iFIT

### Model:

- Flow control valve made of brass, impact resistant plastic and EPDM seals
- Both sides connection to COOL-FIT 2.0 Push System
- Measuring accuracy:  $\pm 10\%$  of the displayed value
- Insulation made of NBR and shells of TPE
- Package contents: 1x valve, 2x adaptors, 2x compression rings, 1x insulation shell

d (mm)	D (mm)	DN (mm)	PN (bar)	Code	Weight (kg)	Dos (mm)	Lmax (mm)	z (mm)
25	54	20	10	<b>138 984 027</b>	1.338	86	332	238
32	61	25	10	<b>138 984 028</b>	1.328	86	332	238

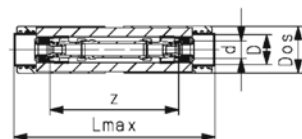



**COOL-FIT 2.0 Push System Flow control valve  
With Eurocone and G-thread connection**

**Model:**

- Flow control valve made of brass, impact resistant plastic and EPDM seals
- One side connection to COOL-FIT 2.0 Push System
- One side connection with thread
- Measuring accuracy:  $\pm 10\%$  of the displayed value
- Insulation made of NBR and shells of TPE
- Package contents: 1x valve, 1x adaptor, 1x compression ring, 1x insulation shell

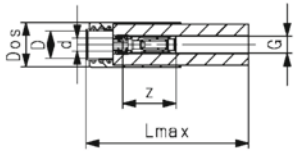

d (mm)	D (mm)	Thread (inch)	Size (mm)	DN (mm)	PN (bar)	Code	Weight (kg)	Dos (mm)	Lmax (mm)	z (mm)
16	44	G	3/4	12	10	<b>138 984 015</b>	0.426	69	252	72
20	48	G	3/4	15	10	<b>138 984 016</b>	0.448	69	252	83



**COOL-FIT 2.0 Push System Flow control valve  
With iFIT and G-thread connection**

**Model:**

- Flow control valve made of brass, impact resistant plastic and EPDM seals
- One side connection to COOL-FIT 2.0 Push System
- One side connection with thread
- Measuring accuracy:  $\pm 10\%$  of the displayed value
- Insulation made of NBR and shells of TPE
- Package contents: 1x valve, 1x adaptor, 1x compression ring, 1x insulation shell

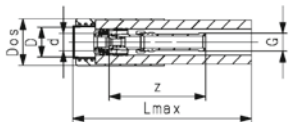

d (mm)	D (mm)	Thread (inch)	Size (mm)	DN (mm)	PN (bar)	Code	Weight (kg)	Dos (mm)	Lmax (mm)	z (mm)
25	54	G	1	20	10	<b>138 984 017</b>	0.887	86	332	179
32	61	G	1	25	10	<b>138 984 018</b>	0.882	86	332	179

# COOL-FIT 2.0 Push System Accessories



## COOL-FIT 2.0 Push System Adaptor kit

### Model:

- Adapter made of high-performance plastic PPSU
- Compression ring made of PP-H
- Package contents: 1x adaptor, 1x compression ring

### Note:

Additionally needed for COOL-FIT 2.0 Push System, T 90° equal and T90° reduced

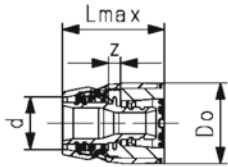

d (mm)	D (mm)	DN (mm)	PN (bar)	Code	Weight (kg)	Lmax (mm)	z (mm)	Do (mm)
16	44	12	16	<b>738 904 055</b>	0.045	48	4.5	29
20	48	15	16	<b>738 904 056</b>	0.039	49	4.5	33
25	54	20	16	<b>738 904 057</b>	0.104	62	7.5	44
32	61	25	16	<b>738 904 058</b>	0.099	63	7.5	50

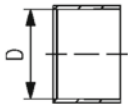

## iFIT Adaptor PPSU

- Material: PPSU, PA

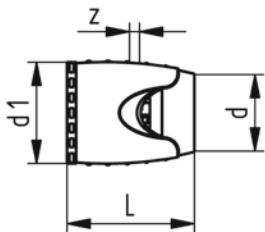

d (mm)	d1 (mm)	Code	SP	Weight (kg)	L (mm)	z (mm)
16	30	<b>762 101 030</b>	10	0.024	48	5
20	34	<b>762 101 031</b>	10	0.028	49	5
25	45	<b>762 101 034</b>	5	0.070	62	8
32	52	<b>762 101 035</b>	5	0.085	63	8





### COOL-FIT 2.0 Push System Pipe shell

**Model:**

- Shell for easy installation in standard pipe clips

d (mm)	D (mm)	Do (mm)	Code	SP	Weight (kg)	Lmax (mm)
16	44	52	<b>738 014 005</b>	50	0.080	200
20	48	56	<b>738 014 006</b>	40	0.086	200
25	54	62	<b>738 014 007</b>	30	0.096	200
32	61	69	<b>738 014 008</b>	30	0.107	200

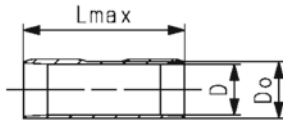

### iFIT Transition module brass With male thread

- Material: brass, dezincification resistant
- Connection: male thread
- \*as long as stock last

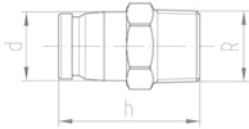

	d (mm)	Thread Type	Size (inch)	Code	SP	Weight (kg)	h (mm)
*	16 - 20	R	3/8	<b>762 101 346</b>	5	0.057	42
*	16 - 20	R	1/2	<b>762 101 265</b>	10	0.060	42
*	16 - 20	R	3/4	<b>762 101 266</b>	10	0.071	43
*	25 - 32	R	3/4	<b>762 101 277</b>	2	0.135	51
*	25 - 32	R	1	<b>762 101 278</b>	2	0.175	55



### iFIT Transition module brass With female thread

- Material: brass, dezincification resistant
- Connection: female thread
- \*as long as stock last

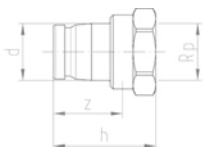

	d (mm)	Thread Type	Size (inch)	Code	SP	Weight (kg)	h (mm)	z (mm)
*	16 - 20	Rp	1/2	<b>762 101 267</b>	10	0.065	36	23
*	16 - 20	Rp	3/4	<b>762 101 268</b>	10	0.085	39	24
*	25 - 32	Rp	3/4	<b>762 101 279</b>	2	0.127	45	31
*	25 - 32	Rp	1	<b>762 101 280</b>	2	0.175	49	32

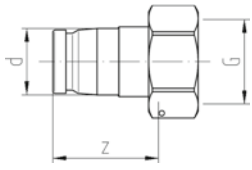
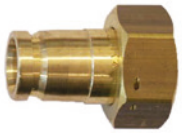

**iFIT Transition union module brass**  
**With flat sealed**

- Material: brass, dezincification resistant
- Supplied with: sealing

d (mm)	Thread Type	Size (inch)	Code	SP	Weight (kg)	z (mm)
16 - 20	G	½	<b>762 101 276</b>	2	0.070	41
16 - 20	G	¾	<b>762 101 273</b>	5	0.064	35
25 - 32	G	¾	<b>762 101 281</b>	2	0.155	48
25 - 32	G	1	<b>762 101 282</b>	1	0.179	55
25 - 32	G	1 ¼	<b>762 101 283</b>	1	0.251	48
25 - 32	G	1 ½	<b>762 101 284</b>	1	0.357	50

# COOL-FIT 2.0 Push System Tools



## iFIT Tool set for ML- and PB pipes plastic

d16 / d20 with pipe scissor, d25 / d32 with pipe cutter

d (mm)	Code	SP	Weight (kg)
16 / 20	<b>762 101 122</b>	1	1.163
25 / 32	<b>762 101 133</b>	1	1.371



## iFIT Chamfering tool for ML- and PB pipes

- Material: steel, plastic

d (mm)	Code	SP	Weight (kg)
16	<b>762 101 116</b>	1	0.188
20	<b>762 101 120</b>	1	0.205
25	<b>762 101 125</b>	1	0.252
32	<b>762 101 132</b>	1	0.323



## iFIT plastic pipe cutter For ML- and PB pipes d16-d32

d (mm)	Code	SP	Weight (kg)
16 - 32	<b>762 101 117</b>	1	0.386
Spare blades	<b>762 101 118</b>	1	0.005



## iFIT Chamfering tool to battery tools metal

d (mm)	Code	SP	Weight (kg)
16	<b>762 101 351</b>	1	0.188
20	<b>762 101 352</b>	1	0.205
25	<b>762 101 353</b>	1	0.252
32	<b>762 101 354</b>	1	0.323



## iFIT Grab rail set metal

d (mm)	Code	SP	Weight (kg)
16 - 32	<b>762 101 361</b>	1	0.050



### iFIT Quick-change insert metal

d (mm)	Code	SP	Weight (kg)
16 - 32	<b>762 101 362</b>	1	0.039



### iFIT Tool case empty plastic For chamfering tool

d (mm)	Code	SP	Weight (kg)
16 - 32	<b>762 101 363</b>	1	2.000



### iFIT Outside pipe bending tool metal For ML pipes

- Material: metal

d (mm)	Code	SP	Weight (kg)	L (mm)
16	<b>762 101 112</b>	1	0.442	500
20	<b>762 101 113</b>	1	0.541	500
25	<b>762 101 114</b>	1	0.636	500
32	<b>762 101 115</b>	1	0.798	500



**Notes**

---

---

---

---

---

---

---

---

---

---

---

---

---

---

---

---

---

---

---

---

---

---

---

---

---

---

---

---

---

---



## Local support around the world

Visit our webpage to get in touch with your local specialist:

[www.gfps.com/our-locations](http://www.gfps.com/our-locations)



The information and technical data (altogether "Data") herein are not binding, unless explicitly confirmed in writing.  
The Data neither constitutes any expressed, implied or warranted characteristics, nor guaranteed properties or a guaranteed durability. All Data is subject to modification. The General Terms and Conditions of Sale of Georg Fischer Piping Systems apply.