

GF Piping Systems

+GF+

# MULTI/JOINT<sup>®</sup> 3000 Plus

2" – 41"

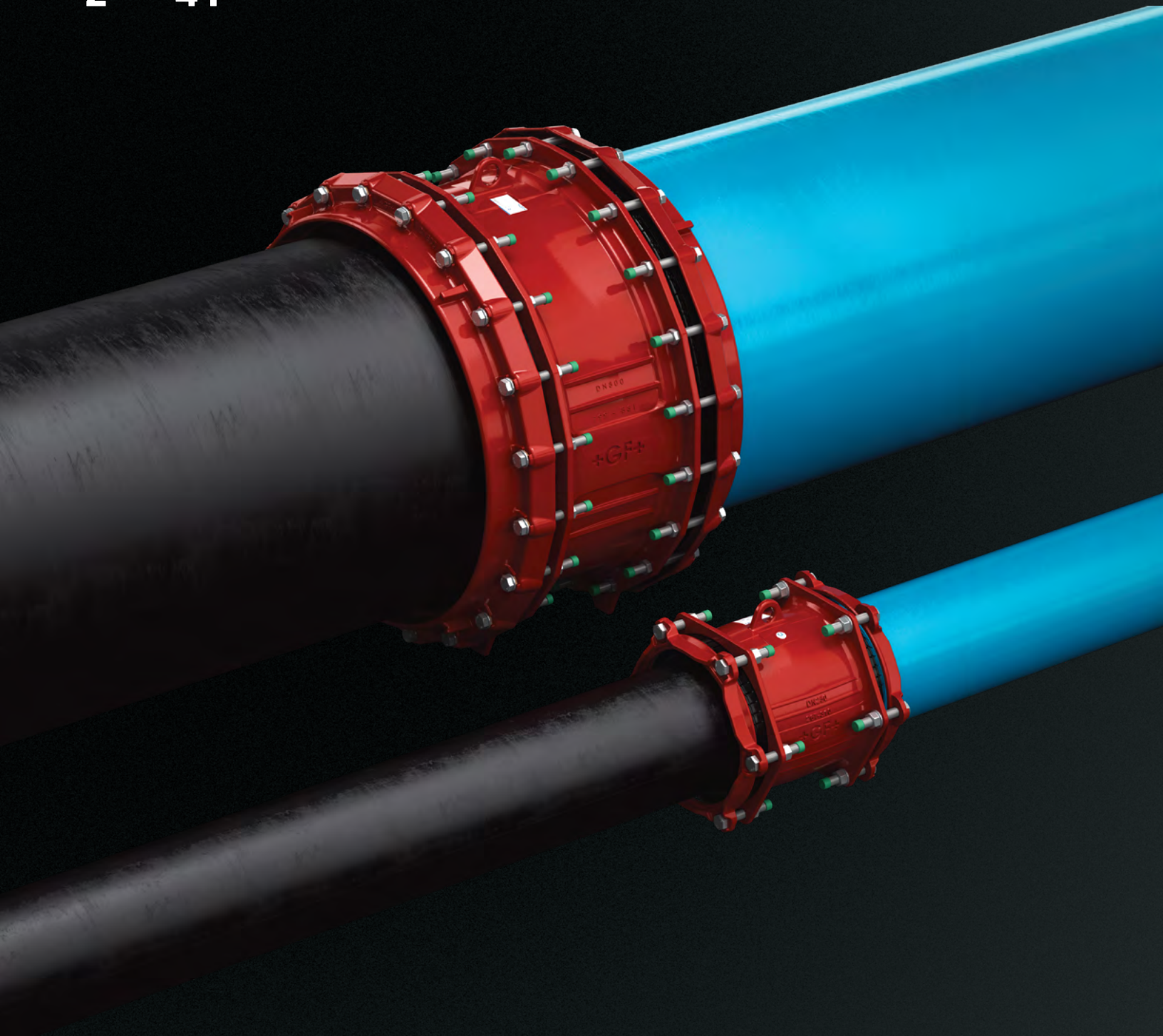

The perfect fit for your piping systems

# MULTI/JOINT® 3000 Plus

**Repairing and connecting water and gas pipelines are often challenging. For instance, you may encounter pipes of various materials in the ground. Jointing methods such as flanging, welding, and using thrust blocks can be very time consuming. By introducing MULTI/JOINT® 3000 Plus, we provide an ideal solution tailored to your requirements, enhancing operational efficiency while simultaneously reducing costs. This is the answer when a flexible restraint connection is required.**

## State of the Art Sealing System

Featuring a patented restraint sealing system, the wide range MULTI/JOINT® 3000 Plus fittings ensure a secure and leak tight connection for all water and gas pipes, above and below ground.

The ductile iron fittings are available in dimensions from 2" up to 41" and are quick, safe, and simple to install. The system has an internationally proven track record of over 30 years, making it a trusted and preferred choice for professionals worldwide.

## Reduce Your Stock Costs

Thanks to the 'one-size fits and grips all' principle, MULTI/JOINT® 3000 Plus is suitable for all pipe materials and for pipes with different outside diameters. This allows stock reductions, saving shelf space and costs. The fittings are reusable, suitable for temporary use, and easy to install without special tools. MULTI/JOINT® 3000 Plus fittings are durable, corrosion-proof, and have a technical life expectancy of 50 years. Connections with MULTI/JOINT® provide you peace of mind for all your piping projects.

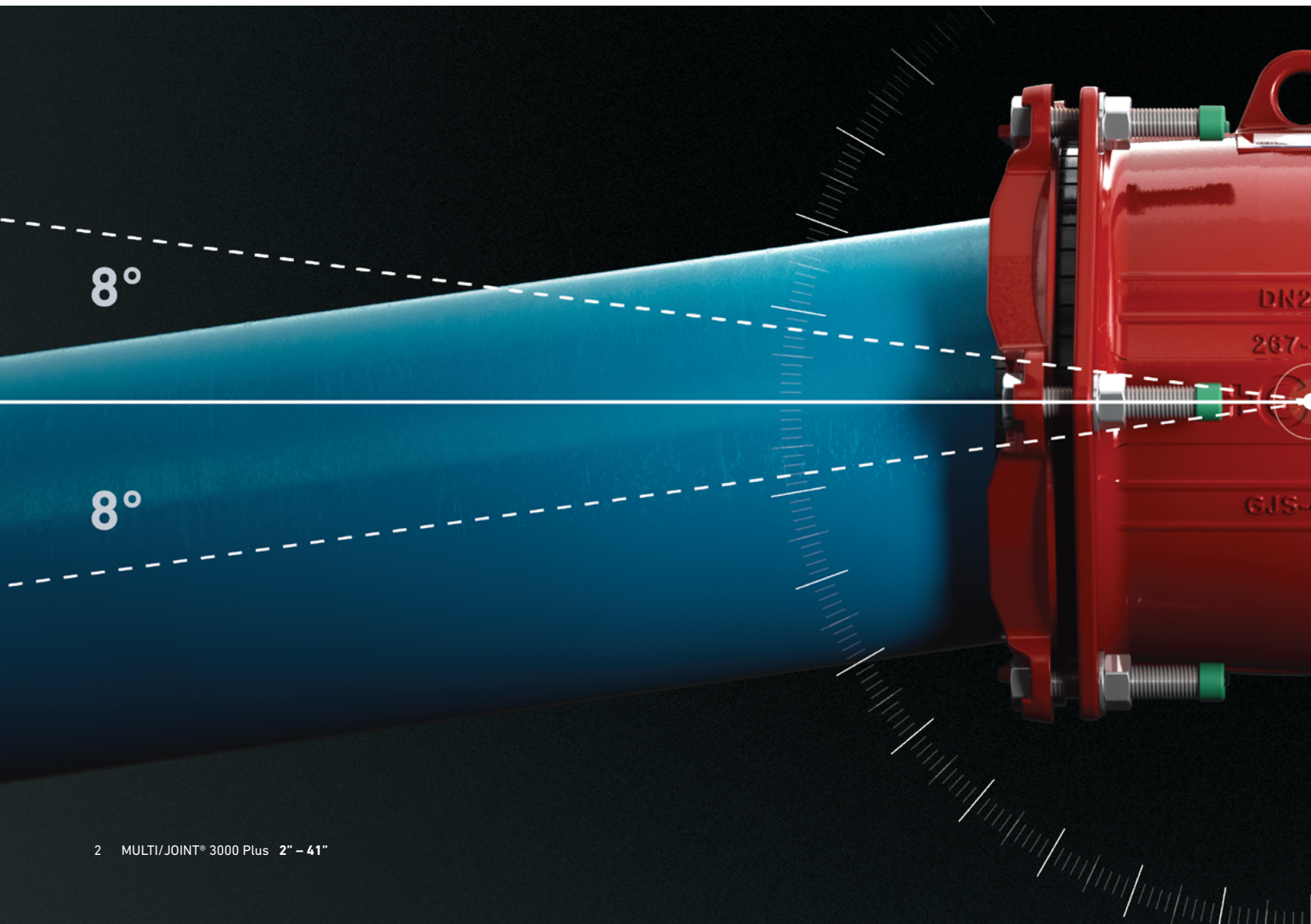

### Angularity

The MULTI/JOINT® 3000 Plus system has a nominal angularity of 8 degrees per socket end. For a coupling this means a nominal angularity of maximum 16 degrees. The angularity ensures flexibility during and after installation. The flexibility allows the pipe to move in the fitting after installation without compromising functionality. This can compensate for differential ground settlement after the trench is backfilled.

## Your Benefits

- Peace of mind
- Quick, safe, and simple installation
- Reduction of your stock costs thanks to the 'one-size fits and grips all' principle
- One piece, stab-fit installation
- Accommodates 16 degrees of angularity (8 degrees on each end)
- No need for thrust blocks
- Suitable for all pipe materials, such as (D)CI, AC, PVC(O), PE and (stainless) steel

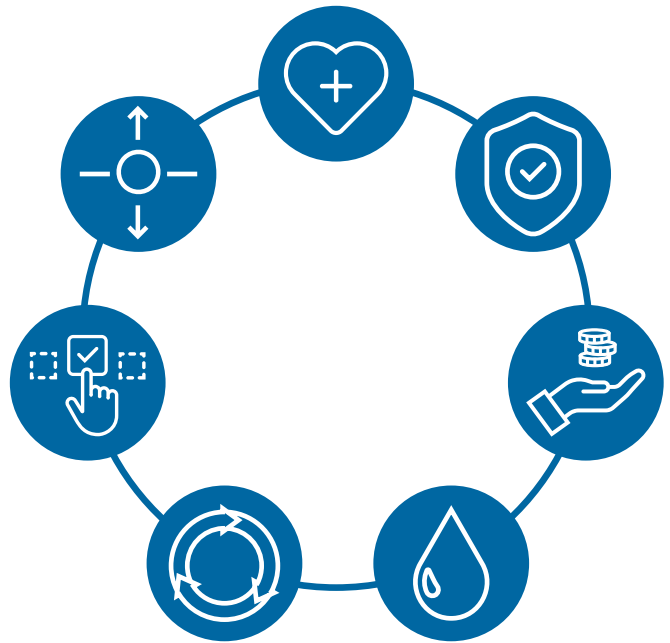

- Durable and corrosion-proof
- Reusable
- Applicable for under and above ground use

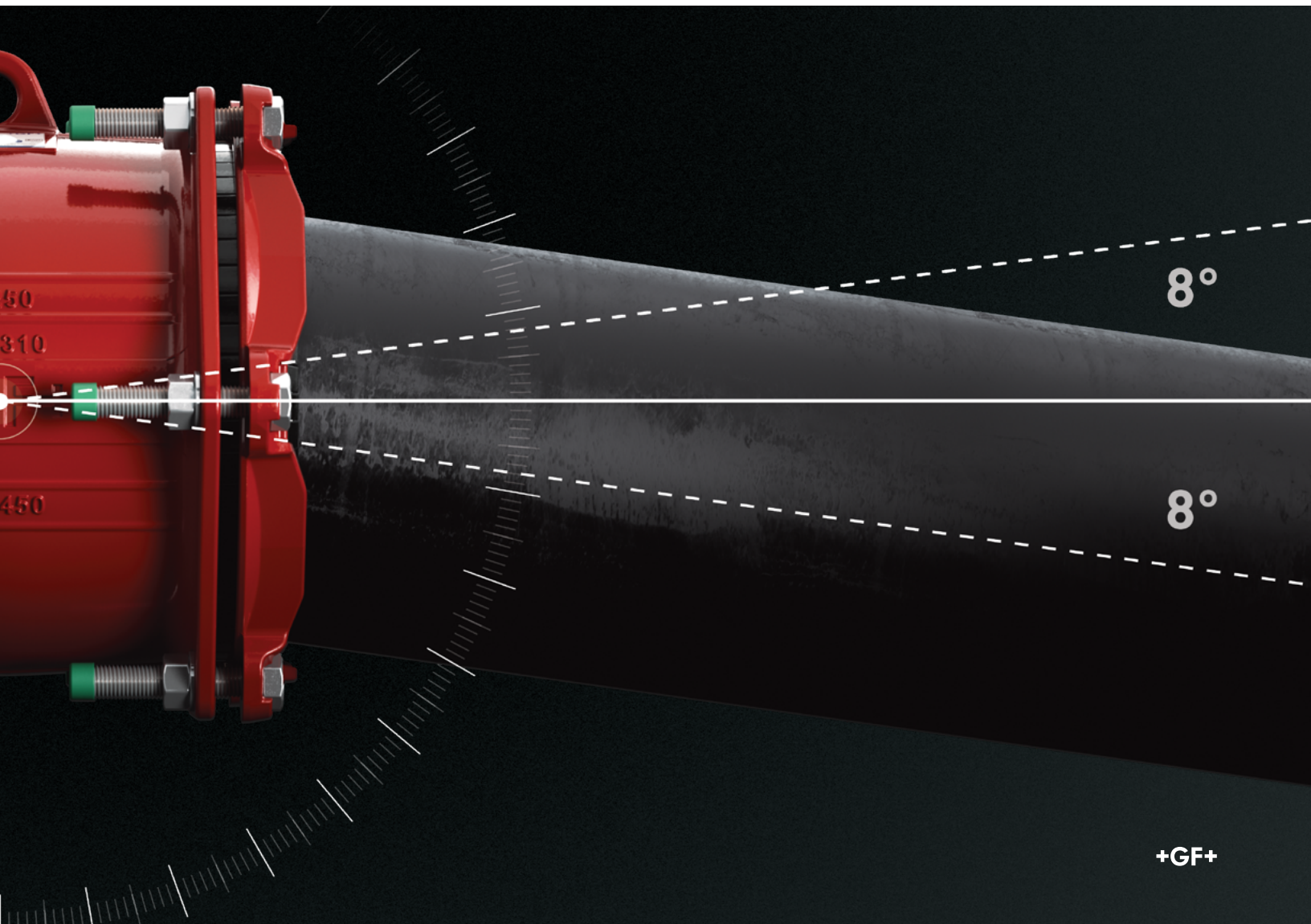

Durable and Reliable

# High Quality Materials

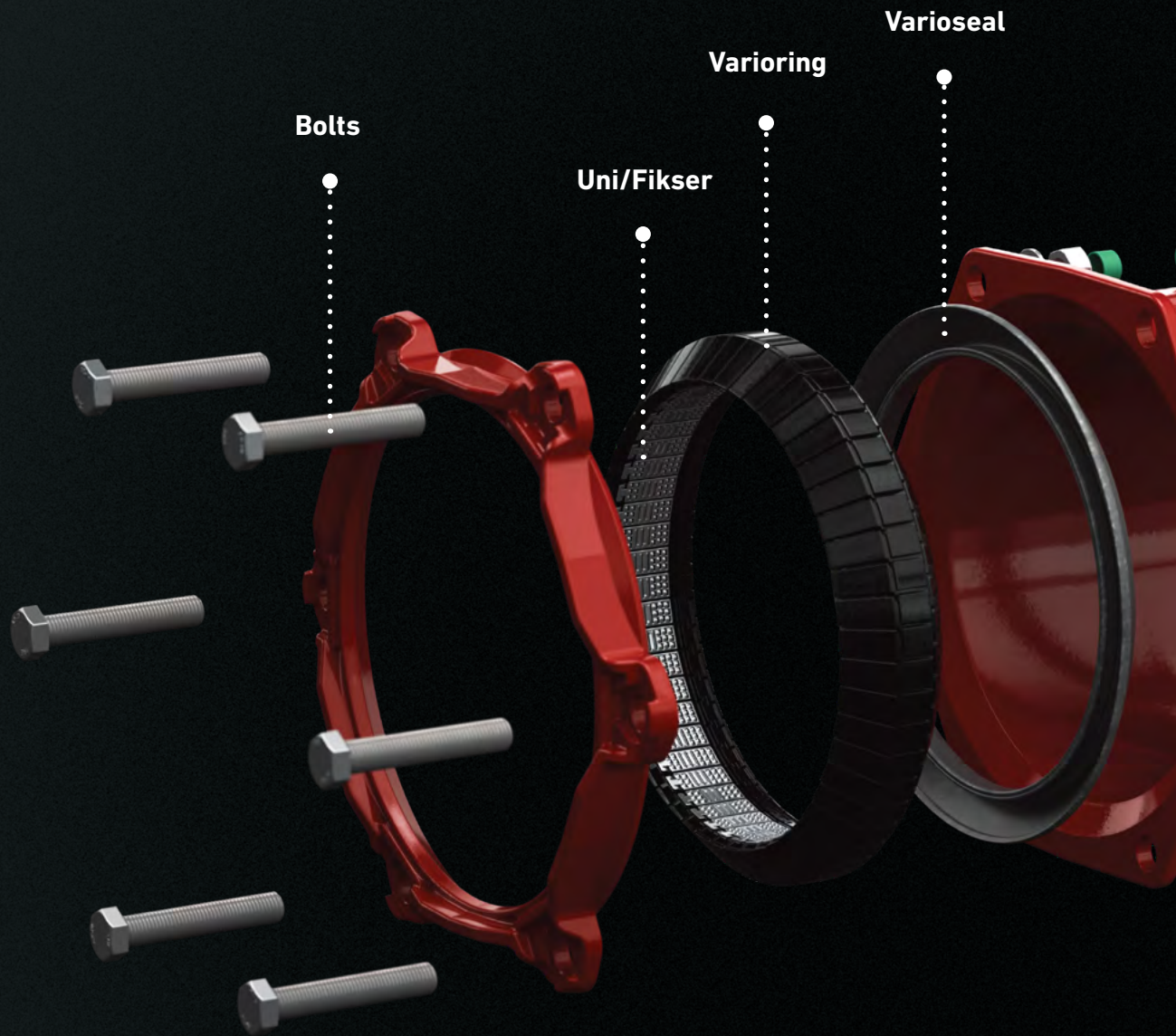

## Quick, Safe, and Simple

The bolts, nuts, and washers are made of stainless steel AISI 304 or AISI 316. The nuts are galvanized and passivated. The bolts are reversible and Lubo coated to prevent cold welding. They are perfect for reuse and make tightening very easy.



## Uni/Fiks Ring: Restraint System

The gripping system consists of a Uni/Fiks ring which contains numerous stainless steel grippers: the Uni/Fiksers. Together with the Varioseal made of EPDM or NBR, the MULTI/JOINT® ensures a restraint and leak-tight connection.

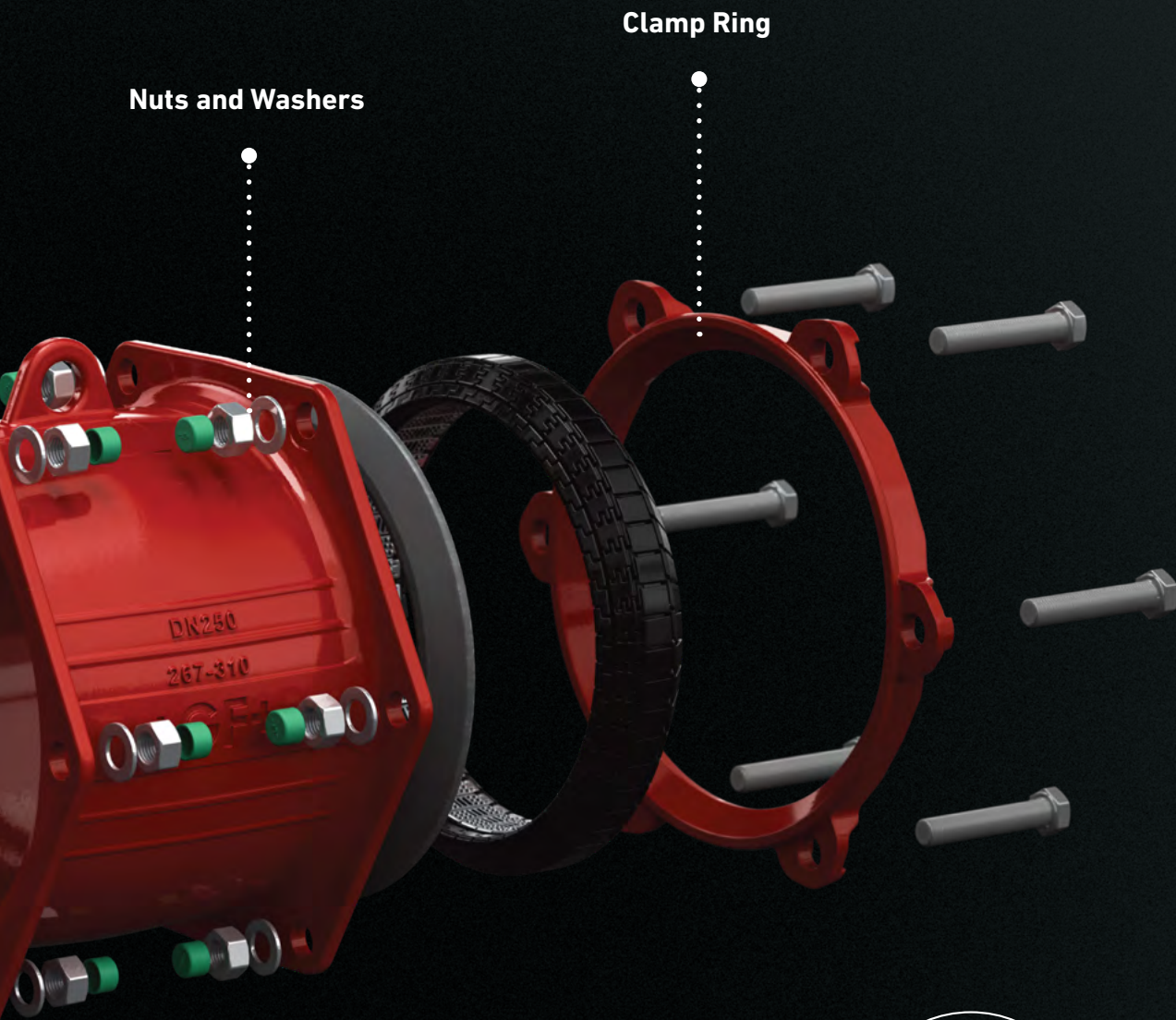

Nuts and Washers

Clamp Ring



**Corrosion Free Fitting**

The body and clamp ring are made of ductile iron in accordance with ASTM A536 grade 65-45-12. These components are coated with Resicoat® epoxy powder coating, ensuring a corrosion free MULTI/JOINT® which is GSK certified.



**Hygiene Protection**

All MULTI/JOINT® fittings have hygiene protection; the fitting will stay clean from production to point of use. Hygiene caps are made from recycled plastic.

One Size Fits and Grips All

# MULTI/JOINT® 3000 Plus

## 2" - 41"

### Fields of Application

- Maintenance and repair
- Water distribution
- Water transport
- Waste water
- Gas distribution
- Industrial applications

Versatile Solutions

# Suitable for All Pipe Materials

Frequently, the need arises to connect existing pipes with new pipes that have varying outside diameters and differing pipe materials. Thanks to the unique wide range sealing system of the restraint MULTI/JOINT® fittings, quick connections of all kinds of pipes can be achieved without special tools. As long as the nominal diameters are the same, one-size fits and grips all.

MULTI/JOINT® 3000 Plus has a range of up to 1.693" and connects pipes from 1.811" - 42.283". The restraint fittings are suitable for applications in water up to 232 psi and in gas up to 116 psi.

## For All Pipe Materials

- PE
- PVC/PVCO
- Grey Cast Iron
- Cast Iron/ Ductile Cast Iron
- Asbestos Cement
- Stainless Steel/Steel
- Gas distribution
- Glass Reinforced Plastic

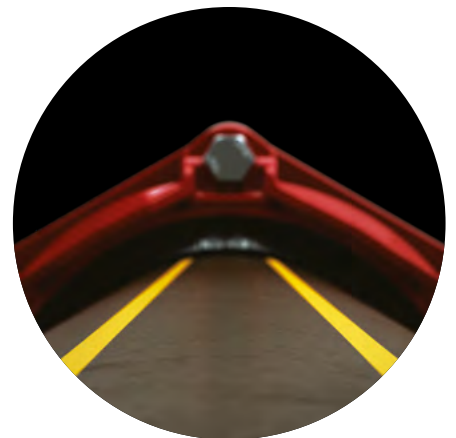
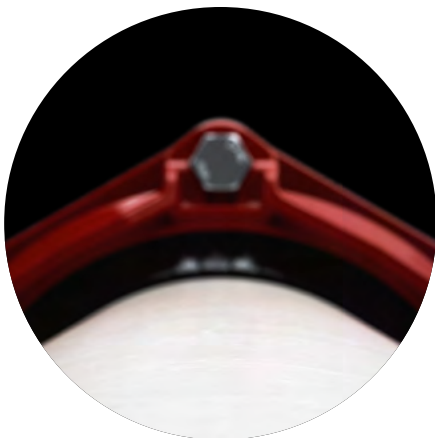



Watch the video





One Size Fits and Grips All

# Unique Sealing System

The patented sealing system of the MULTI/JOINT®, called Uni/Fiks ring, is the heart of the system and consists of multiple parts: a rubber seal, plastic segments, and stainless steel grippers. Together they ensure a progressive seal and leak-tight connection that gives you peace of mind.

### Varioseal

The Varioseal gasket is characterized by its thin but durable design, ensuring optimal sealing force over the full lifespan of the fitting. The Varioseal which is available in EPDM and NBR is firmly embedded in the Varioring. During the installation process this unique sealing system ensures that every connection is leak-tight.

### Plastic Segments

The plastic segments in the Varioring enable large range coverage in pipe outside diameters, making MULTI/JOINT® a true wide range solution. For fitting size 2" up to 5",

the segments consist of one part that is made of POM (Polyoxymethylene). The segments for ring size 6" up to 41" consist of a wedge (made of POM) and a topple (made of polyamide). In fitting sizes 17" up to 41" a clip has been added to firmly position the Varioring inside the body of the fitting. Together with the Varioseal, the segments provide you ultimate flexibility.

### Uni/Fiksers

The Uni/Fiksers are stainless steel grippers and ensure optimal pull out resistance both on rigid pipe materials as well as on plastic pipes without compromise. The inclusion of Uni/Fiksers eliminates the requirement for thrust blocks. This restraint connection has been proven to be effective for water applications up to 232 psi and gas applications up to 116 psi.

Uni/Fiks ring  
17" - 41"

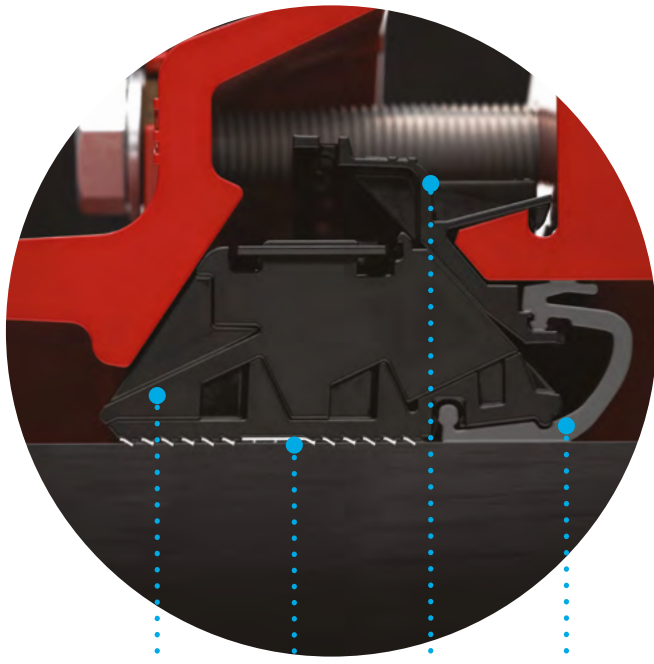

Plastic segment    Uni/Fikser    Clip    Varioseal

Uni/Fiks ring  
6" - 16"

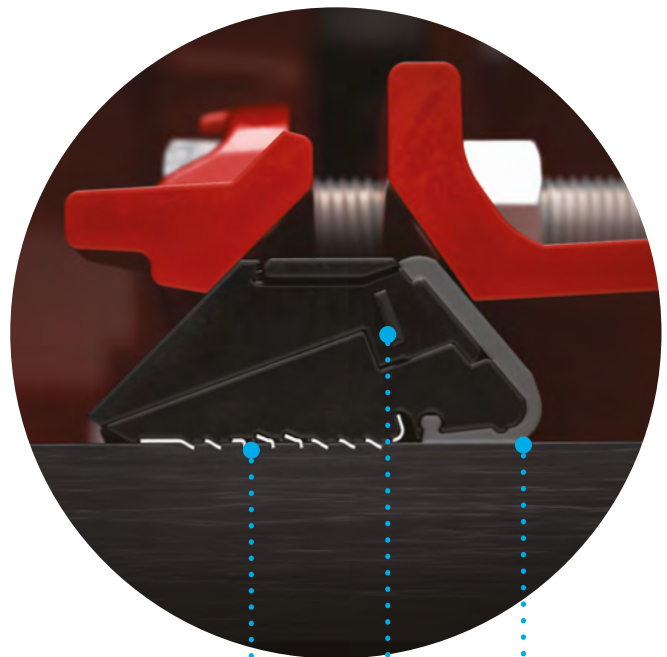

Uni/Fikser    Plastic segment    Varioseal

One Complete System

# Models and Types



Coupling

MULTI/JOINT® 3007



Flange Adaptor

MULTI/JOINT® 3057



Reduced Coupling

MULTI/JOINT® 3107



Reduced Flange Adaptor

MULTI/JOINT® 3157



End Cap - Blind

MULTI/JOINT® 3207



End Cap - Threaded 2"

MULTI/JOINT® 3207



Bend

MULTI/JOINT® 3407



Certified to  
NSF/ANSI 61



## Insert stiffener

In case of connecting PE pipes always install an insert stiffener. In case of connecting PVC pipes install an insert stiffener if the wall thickness is smaller than SDR21.

# Size, Range, and Pressure

Size (inch)	Range (inch)	Working pressure*	Size (inch)	Range (inch)	Working pressure*
2	1.811 - 2.795	232 psi	19	18.937 - 20.196	150 psi
2 ½	2.480 - 3.543	232 psi	20	19.685 - 20.944	150 psi
3	3.307 - 4.133	232 psi	22	21.574 - 22.834	150 psi
4	4.094 - 5.196	232 psi	24	23.818 - 25.078	150 psi
5	5.196 - 6.102	232 psi	26	24.803 - 26.063	150 psi
6	6.062 - 7.559	232 psi	27	26.181 - 27.441	150 psi
8	7.559 - 9.133	232 psi	28	27.913 - 29.173	150 psi
9	9.050 - 10.551	232 psi	30	29.331 - 30.591	150 psi
10	10.500 - 12.204	232 psi	32	31.456 - 32.740	150 psi
12	12.401 - 14.015	232 psi	34	32.952 - 34.212	150 psi
14	13.858 - 15.472	232 psi**	36	35.393 - 36.653	150 psi
16	15.433 - 17.047	232 psi**	37	36.969 - 38.228	150 psi
17	17.000 - 18.267	150 psi	40	39.133 - 40.393	150 psi
18	17.716 - 18.976	150 psi	41	41.023 - 42.283	150 psi

\* Restraint \*\* 150 psi for plastic pipe materials

# Technical Specifications

<b>Body and clamp ring</b>	Ductile iron ASTM A536 grade 65-45-12.
<b>Coating</b>	Resicoat® Epoxy powder coating, type RT 9000 R4, NSF 61 approved. Colour red (RAL 3011). Minimum layer thickness 10 mil, in accordance with AWWA C116/A21.16-22.
<b>Varioseal/rubber gasket</b>	Potable water: EPDM, NSF 61 approved. Non potable water and gas: NBR.
<b>Uni/Fiks ring</b>	POM (polyoxymethylene) and/or glass fiber filled polyamide.
<b>Uni/Fiksers</b>	Stainless steel AISI 316.
<b>Bolts and nuts</b>	Stainless steel AISI 304 or stainless steel AISI 316. Bolts are Lubo coated, nuts are galvanised and passivated to prevent cold welding.
<b>Washers</b>	Stainless steel AISI 304 or stainless steel AISI 316.
<b>Flanges</b>	Drilling pattern in accordance with AWWA C110 or patterns PN16/10 in accordance with EN 1092-2.
<b>Working temperature</b>	-5°C to +50°C / 23°F to 122°F.
<b>Working pressure (PFA)*</b>	Restraint: up to 232 psi water and up to 116 psi gas. Non restraint: up to 362 psi water and up to 116 psi gas.
<b>Certificate</b>	NSF, ACS (France), Belgaqua (Belgium), WRc (United Kingdom), ÖVGW (Austria), DVGW (Germany), SVGW (Switzerland), and KIWA (The Netherlands). EN 14525: ÖVGW, SVGW, and KIWA.
<b>Standards</b>	AWWA C219-23, AWWA C111/A21.11-23, AWWA C153-19, RMDCS 02511, NSF 61, ASTM F1476-07(2019), AWWA C116/A21.16-22.

\* For details see user manual or contact your supplier.

## Contact information

**Georg Fischer Piping Systems Ltd**  
41 Keyes Court  
Woodbridge, Ontario  
L4H 0W6, Canada

Tel: +1 905-670-8005  
Fax: +1 905-670-8005

[ca.ps@georgfischer.com](mailto:ca.ps@georgfischer.com)  
[www.gfps.com/ca](http://www.gfps.com/ca)

