

# Expanding the Pro-Range

Ball Valve 546 Pro and 543 Pro





The Pro lineup

# Driven to maximum performance

Ball valves are an indispensable part of every piping system. They come in a variety of different sizes, materials, and actuation possibilities to regulate and control processes in the most diverse fields of application. To ensure the failsafe operation of the whole system, it is essential to trust in the highest quality components with embedded safety measures to avoid unexpected downtimes and repairs.

This is why ball valves from GF Piping Systems are always the ideal solution. Whether in the chemical process industry, microelectronics, or water treatment: GF Piping Systems reliably covers a variety of applications with its broad product range. From a basic, manually operated shut-off valve to a fully automated ball valve, our solutions offer genuine added value and meet the highest performance and quality requirements without compromise.



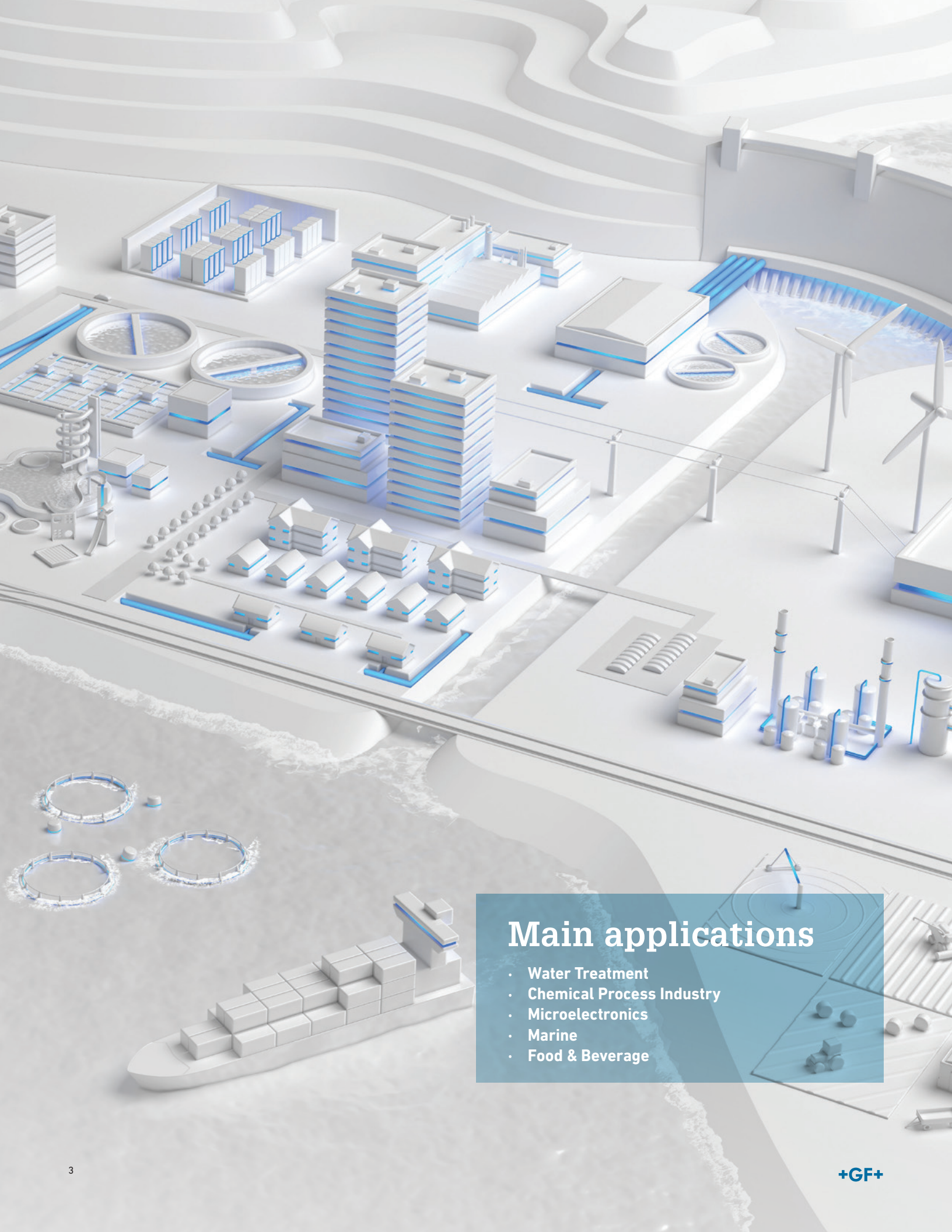

## Main applications

- Water Treatment
- Chemical Process Industry
- Microelectronics
- Marine
- Food & Beverage

The Pro lineup

# Modular and flexible design

Our comprehensive portfolio of highest quality ball valves and decades of experience enable us to ensure state-of-the-art technology and customizable solutions for every application. The versatile, modular design and the wide range of available materials make the Ball Valve Pro lineup by GF Piping Systems the perfect solution for every need.

When optimizing a piping system, the Ball Valve 546 Pro and the Ball Valve 543 Pro are decisive components in increasing overall efficiency. They help cut service and retrofitting costs while reducing the risk of operating errors. The Pro lineup meets today's demands for valve technology with the usual high-quality standards of GF Piping Systems. Thanks to consistent installation length with previous models, optional accessories can quickly and easily be adapted to meet new requirements.

## 100% reliable

Regarding reliability, the next generation of 2-way and 3-way Ball Valves match the originals high standards and even improve upon them thanks to being low in maintenance, available worldwide in a wide variety of materials, and having received the most certification approvals.

## 100% flexible

Thanks to their modular design, the Ball Valve 546 Pro and 543 Pro can always be adapted to your requirements. Their flexibility meets all-electric, pneumatic, or manual operation requirements, including optional accessories.

## Contribution to digitalization

The 546 Pro and the 543 Pro can easily be retrofitted with electrical position feedback and provide relevant component information via the individual Data-Matrix-Code on each valve.







### **Two-level safety**

To protect sensitive processes against the risks of errors, the Ball Valve Pro line-up comes as standard with a locking element and the possibility of using a locking device.

### **Complete compatibility**

Due to the same installation length and thread as the predecessor valves, no complicated and expensive assembly work is necessary. The 546 Pro and the 543 Pro can be retrofitted with an actuator and accessories during operation and at a low cost.

### **Replacement within minutes**

The newly designed security breakpoint in the interface allows the user to replace the coupling piece within a few minutes and without interruption if an automated valve is subject to wear.

# Swiss quality for highest reliability

Like their predecessors, the Ball Valve 546 Pro and 543 Pro are produced by GF Piping Systems in Seewis (Grisons), Switzerland. High-quality manual and automatic valves have been produced here for over half a century. They combine technological innovation with the highest material selection standards, manufacturing, and quality testing for safety, durability, and reliability.





## Product features

- 1 Ergonomic lever, lockable as standard
- 2 Quick label on request
- 3 Integrated tool for the union bush
- 4 Interface for flexible automation and accessories
- 5 Reinforced security break point in the stem interface
- 6 Double stem seals
- 7 Dynamic backing seal
- 8 Smooth spherical surface
- 9 Sawtooth thread suitable for plastics
- 10 Fastening system with integrated threaded bushes
- 11 Data-Matrix-Code



# Interoperable precision

The Ball Valve 543 Pro is the ideal valve for all mixing and distribution processes, including redirecting, mixing, distributing, or even shutting off a medium in areas of application within the chemical process industry, or water treatment applications.

## L-Port



Distribution function in the starting position



Mixing function with reduced flow



Distribution function



Outlet closed, passage open with reduced flow



Shut-off function



## Flow diagrams

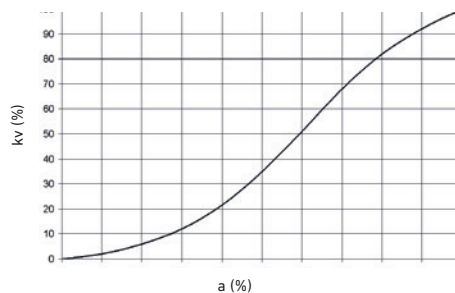
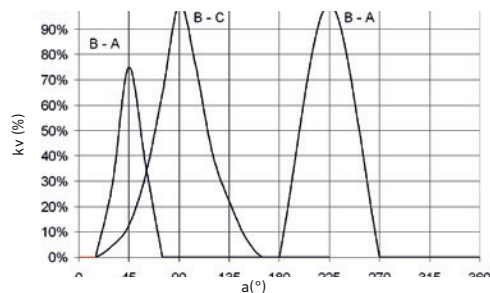





## T-Port



Distribution function in the starting position



Distribution function



Outlet closed, passage open



Distribution function



Shut-off function

### Flow diagrams

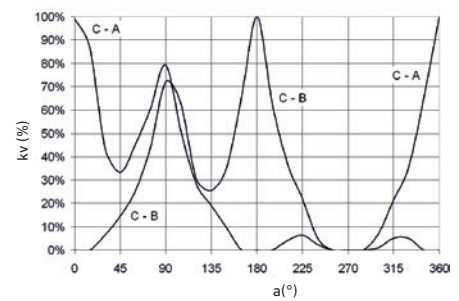
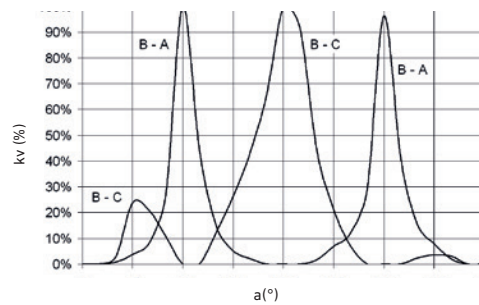

The Pro lineup

# The proven originals improved once again

As the successors of proven originals, the Ball Valve 546 Pro and the Ball Valve 543 Pro have been improved in many ways. A reinforced security break point in the stem interface prevents leaks due to wear or excessive force. Two integrated sealing rings in the stem interface provide double safety. Therefore, the 546 Pro and the 543 Pro offer uncompromising reliability and can be flexibly expanded with optional accessories. All previous quality features of the ball valves have been migrated to the new generations.



## User-friendly operation

The ergonomically designed lever allows easy, precise operation. To protect against unintentional or unauthorized actuation, it is lockable as standard and functions with all-new accessory options. Even a tool for removing the union bush is integrated.



## Safety through dead man's lever

The 546 Pro and 543 Pro are there for you in case you forget: A manual spring return unit ("dead man's lever") ensures that the valve closes automatically when released. This reliable, compact, cost-effective solution ensures end-to-end process safety and easily eliminates potentially far-reaching risks.





#### **Monitoring by the double sensor**

The optional LED position feedback allows the current position of the valve to be centrally recorded and checked at any time – for manually operated and automated valves. The compact dual-sensor fits even in the tightest areas and is protected against the ingress of water and dust (protection class IP67).



#### **Information via Data-Matrix-Code**

The Data-Matrix-Code on the 543 Pro and 546 Pro simplifies the storage of all technical information for each valve and thus enables individual traceability. The faultless identification of each valve facilitates easy installation, service, and repair.



#### **Driven to maximum performance**

Pneumatic and electric actuators from GF Piping Systems help to make processes more efficient and reduce maintenance costs. Where appropriate, they also contribute to digitization by making it easier to access process and component data and use it to optimize the system.

## Pneumatic Actuator & Positioner

# All in one solution

### Precise control

The Electro-pneumatic Positioner was tuned and tested with the Pneumatic Actuator and the Ball Valve 546 Pro / 543 Pro. Thanks to the perfect alignment, precise flow control becomes simple. Additionally, an auto-tune function ensures quick commissioning. The Pneumatic Actuator and the Electro-pneumatic Positioner are also available for diaphragm valves type DIASTAR.

### Pneumatic Actuator

The pneumatic actuators are considerably more compact than earlier models and therefore support compact installation with tighter spacing of PP-GF pipes, leaving more space in order to install all necessary components more easily.

### Automation

Even though valves are pre-assembled, standard interfaces allow easy modification if required. The connection kit is compact and also holds an additional inductive limit switch.

### Connected valves

Flexible sizing to find the right fit - The new design of the interface between the Ball Valve 546 Pro / 543 Pro and the Pneumatic Actuator range enable users to find the right fit in terms of torque and size even in low-pressure applications. Choose from standard configurations or contact GF Piping Systems for customized assemblies.

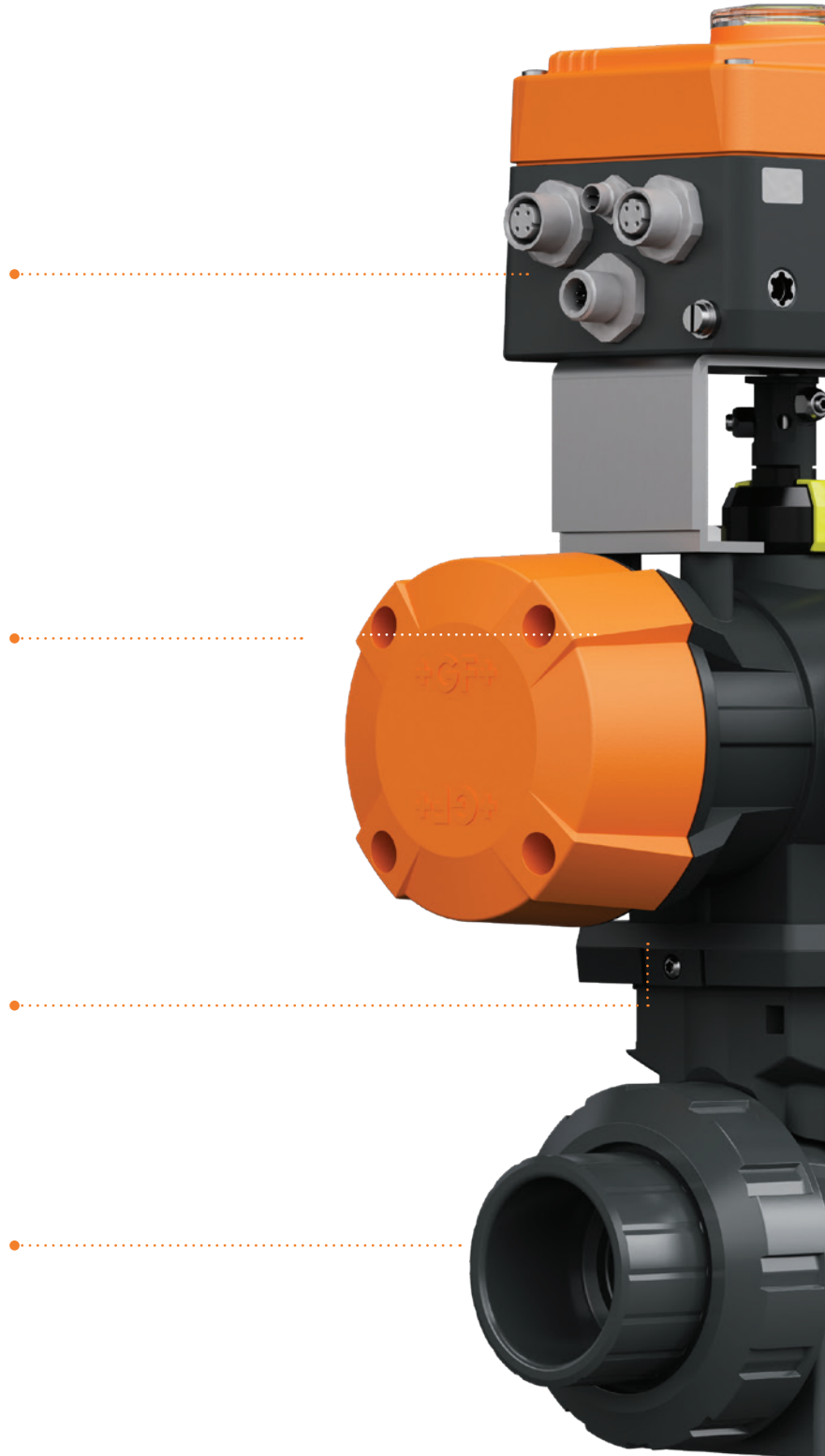





100%

system flexibility

27%

more compact\*



Gateway to digitalization

100%

recyclable composite material

\* maximum difference compared to previous models

Together as one

# We make Process Automation easy

GF Piping Systems is your experienced partner with a full portfolio of measurement, control, actuation components, and valves, which are easy to install and use, and have local support through all project phases. We offer the full package with our products and solutions, providing top-quality installation, a highly skilled team of experts standing by our customers' side every step of the way worldwide, and digitalized services ensuring a project is at the forefront of the market.

## One user experience across the whole control loop

### Accurate measurement is the basis for reliable process control

Physical parameters as well as analytics, including installation fittings, for an effortless combination.

### Precise control throughout your automation loop

Single or dual channel with additional control capabilities.

### Reliable actuation with configuration flexibility

Electric and pneumatic actuators for high flexibility on standardized valve interfaces. A wide range of accessories complete our actuation portfolio.

### The right valve for your application

Ball Valves, Butterfly Valves, Diaphragm Valves, and various process valves including pipe connections that make installation a breeze.

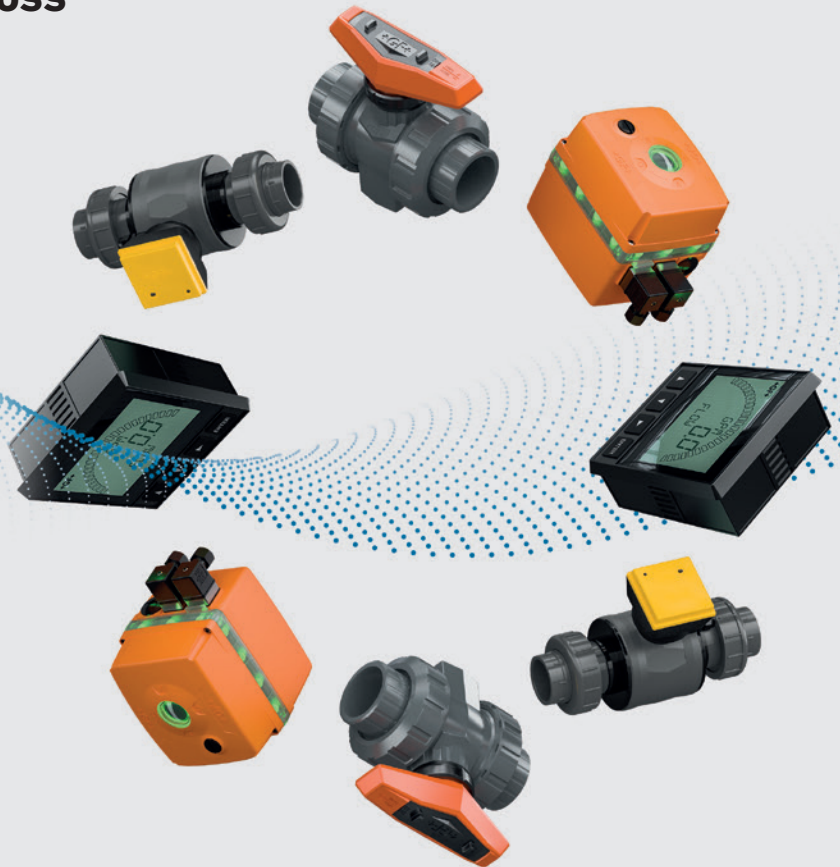

[www.gfps.com/processautomation](http://www.gfps.com/processautomation)



## Specialized Solutions

# Ready when you are

With Specialized Solutions, the global leader GF Piping Systems provides project support every step of the way to achieve construction excellence without interrupting daily business.



### Custom product design and prefabrication

Having your individual needs and application in focus, our customizing teams forge the solution that fits you best, developing custom-made parts to complete systems or special solutions produced in small series, individual consulting and off-site prefabrication.



### Digital libraries

The libraries cover three key areas for the design, creation, and maintenance of a project: Building Information Modeling, the Plant Design Software, and the CAD Library, helping you reduce costs and construction times.



### Engineering

Increase the efficiency of your project with the tailor-made analysis packages from GF Piping Systems and decide which offer is right for you according to your needs. You have the choice between Project Analysis and Advanced Engineering, thus always receiving the appropriate support in every phase of your project. Established knowledge, guiding you through.

[www.gfps.com/specialized-solutions](http://www.gfps.com/specialized-solutions)

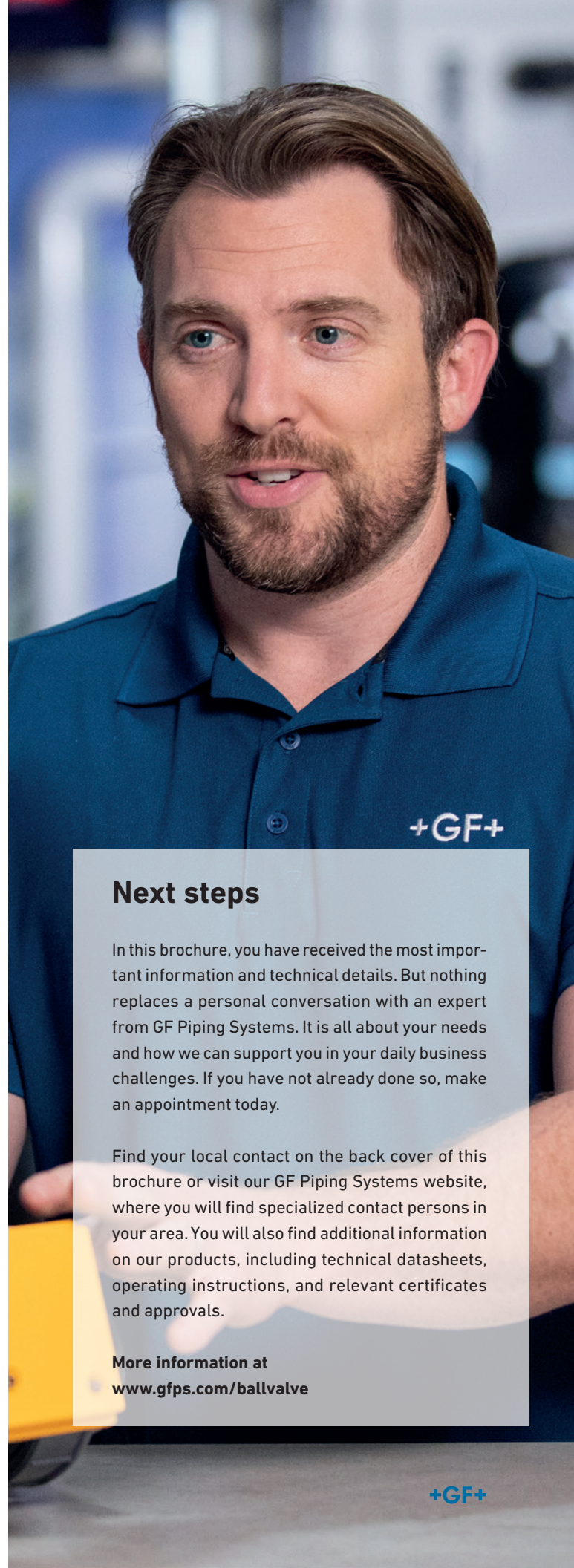

## Next steps

In this brochure, you have received the most important information and technical details. But nothing replaces a personal conversation with an expert from GF Piping Systems. It is all about your needs and how we can support you in your daily business challenges. If you have not already done so, make an appointment today.

Find your local contact on the back cover of this brochure or visit our GF Piping Systems website, where you will find specialized contact persons in your area. You will also find additional information on our products, including technical datasheets, operating instructions, and relevant certificates and approvals.

More information at  
[www.gfps.com/ballvalve](http://www.gfps.com/ballvalve)

# Local support around the world

Visit our webpage to get in touch with your local specialist:  
[www.gfps.com/our-locations](http://www.gfps.com/our-locations)

